



# Reaction to fire test report

Test standard: Ad-hoc test based off ISO 13785-1:2002



Test sponsor: Cladding Safety Victoria (CSV)

System: An aluminium composite panel (ACP) wall system and a mock balcony setup representative of an in-situ façade - [REDACTED]

Job number: RTF230083

Test date: 18 December 2023 Revision: RR1.0

## Quality management

Revision	Date	Information about the report			
RR1.0	29 November 2024	Description	Initial issue.		
			Prepared by	Reviewed by	Authorised by
		Name			
	Signature				

Warringtonfire\* Australia Pty Ltd  
 ABN 81 050 241 524

\*As used herein, The name "Warringtonfire" and its associated IP and branding is used by Warringtonfire Australia Pty Limited in Australia under licence from Warringtonfire Testing and Certification Limited (based in the UK) for a transitional period following the acquisition of Warringtonfire Australia Pty Limited. The Warringtonfire Testing and Certification Limited continues to own the rights to "Warringtonfire" and continues to operate the global "Warringtonfire business" outside of Australia.

## Contents

1.	Introduction .....	4
2.	Test specimen .....	4
2.1	Schedule of components .....	4
3.	Test procedure .....	8
4.	Test measurements and results .....	9
5.	Application of test results .....	16
5.1	Test limitations .....	16
5.2	Variations from the tested specimen .....	16
5.3	Uncertainty of measurements .....	16
Appendix A	Drawings of test assembly .....	17
Appendix B	Photographs.....	22
Appendix C	Chemical Analysis Results .....	33

# 1. Introduction

This report documents the findings of an ad-hoc reaction to fire test of an aluminium composite panel (ACP) wall system and a mock balcony setup representative of an in-situ façade - [REDACTED] performed on 18 December 2023. The test was based off some general requirements of ISO 13785-1:2002.

Warringtonfire performed the test at the request of the test sponsor listed in Table 1.

**Table 1 Test sponsor details**

Test sponsor	Address
Cladding Safety Victoria	717 Bourke Street Docklands VIC 3808 Australia

# 2. Test specimen

## 2.1 Schedule of components

Table 2 describes the test specimen and lists the schedule of components. These were provided by the representatives of the test sponsor and surveyed by Warringtonfire. All measurements were done by Warringtonfire – unless indicated otherwise.

Detailed drawings of the test specimen are provided in Appendix A.

**Table 2 Schedule of components**

Item	Description	
<b>Cladding</b>		
1.	Item name	Aluminium composite panel (ACP)
	Product	[REDACTED]
	Manufacturer/Supplier	[REDACTED]
	Batch	[REDACTED]
	Material	The material was nominated as panels consisting of two layers of aluminium sheets sandwiching a layer (core) of 100% polyethylene (PE) with no filler. Analysis was conducted by Foray Laboratories. Refer to Appendix C for more detailed results.
	Size	As shown in Figure 12. Total thickness – 4.0 mm Skin thickness (both sides) – 0.6 mm
	Measured mass/unit area densities	Panel areal density – 5.5 kg/m <sup>2</sup>
2.	Item name	FR Plasterboard
	Product	[REDACTED]
	Manufacturer/Supplier	[REDACTED]
	Size	Measured board: 2700 mm × 1200 mm × 13 mm
	Batch Date:	[REDACTED]
3.	Item name	Backpan
	Product	[REDACTED]
	Supplier	[REDACTED]
	Size	Measured: 280 mm wide × 1000 mm long × 0.55 mm thick
	Material	Galvanised steel

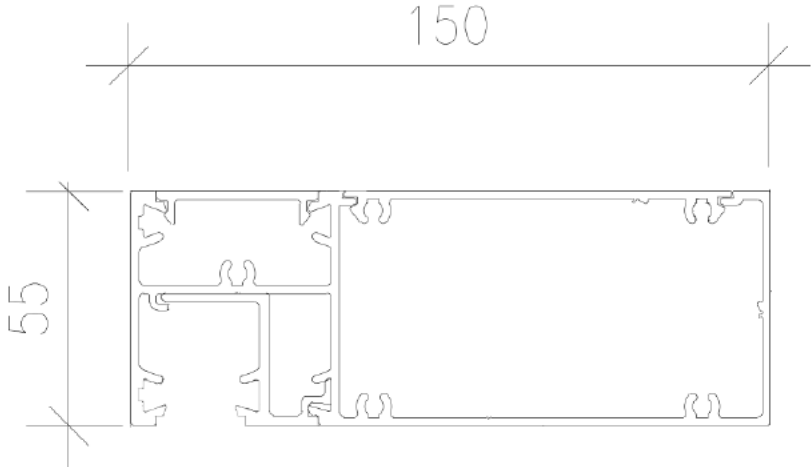
Item	Description	
4.	Item name	"Non-combustible" cladding
	Product	██████████
	Manufacturer/Supplier	██████
	Size	15 mm thick
	Batch	████████████████████
<b>Framing</b>		
5.	Item name	Test rig frame - 90 × 90 SHS frame
	Size	90 mm × 90 mm × 5 mm thick – refer to Figure 13
6.	Item name	██████████ frame mullion ██████████
	Profile	
	Material	6060 T5 aluminium alloy
	Manufacturer/Supplier	██████████
7.	Item name	Furring Channel - framing
	Size	50 mm wide × 28 mm deep × 0.50 BMT
	Material	Galvanised steel
	Manufacturer/Supplier	██████
8.	Item name	██████████ standard direct fix clip
	Size	115 mm wide × 30 mm deep × 30 mm high × 1.5 mm thick
	Material	Galvanised steel
	Manufacturer/Supplier	██████
9.	Item name	Steel frame
	Size	Studs and noggings: 90 mm deep × 40 mm wide × 0.7 BMT
	Installation	The steel framing members were riveted (item 15) to one another.
	Material	██████████
	Manufacturer/Supplier	██████████
<b>Insulation</b>		
10.	Item name	50 mm thick polyethylene terephthalate (PET) insulation
	Density	~13 kg/m <sup>3</sup>
	Manufacturer/Supplier	██████████
11.	Item name	50 mm thick PU Rock Mineral wool sandwich panel

Item	Description	
	Density of core	Unknown
	Manufacturer/Supplier	[REDACTED]
<b>Sealant/Adhesive</b>		
12.	Item name	Weathering sealant
	Product type	Silicone sealant
	Product name	[REDACTED]
	Manufacturer/Supplier	[REDACTED]
	Usage	Placed at ACP edges and over screw and rivet locations.
13.	Item name	Fire-rated sealant
	Product name	[REDACTED]
	Manufacturer/Supplier	[REDACTED]
	Usage	Used to seal the gaps between the back pan (item 3) and the aluminium framing (item 6) behind the air transfer grille (item 18).
<b>Fixings</b>		
14.	Item name	Wafer head screws – zinc coated steel
	Size	6g × 16 to 25 mm long
	Installation	Used to fix mineral wool panel (item 11) to the aluminium mullion (item 6) – four per corner.
15.	Item name	Aluminium rivet
	Size	Ø3 mm
	Installation	Used to fix the air transfer grille (item 18) to the aluminium framing (item 6) and the steel framing (item 9).
16.	Item name	Plasterboard and cladding ([REDACTED]) screws
	Size	8g × 50 to 65 mm - long fine thread SDS
17.	Item name	Furring channel clip screws
	Size	10g × 22 mm long, hex head, self-drilling screws
<b>Other things</b>		
18.	Item name	Air transfer grille
	Product name	[REDACTED]
	Size	940 mm wide × 270 mm tall × 50 mm deep (45° angled blades)
	Material	6060 T5 aluminium alloy
	Installation	Installed within the aluminium framing (item 6) above the ACPs (item 1). The blades were angled at an upward slope starting from the outside going into the wall. The grille was fixed to the aluminium framing using aluminium rivets (item 15), one rivet at each corner of the grille.
	Manufacturer/Supplier	[REDACTED]
19.	Item name	Vermin mesh
	Size	940 mm wide × 270 mm tall
	Material	Coated steel
	Installation	The mesh was installed behind the air transfer grille.
20.	Item name	Aluminium sill with weepholes
	Size	165 mm × 30 mm tall flanges × 2 mm thick. Containing weepholes

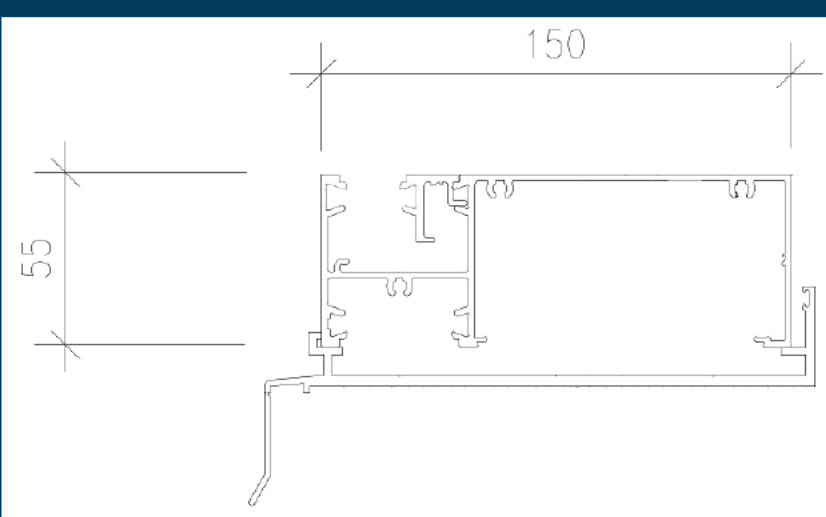
Item	Description
	<div style="display: flex; align-items: center;"> <div style="flex: 1;"> <p><b>Profile</b></p> </div> <div style="flex: 2;">  </div> </div>
Material	6060 T5 aluminium alloy
Manufacturer/Supplier	██████████
Installation	Installed above the cladding board (item 4) compartment residing over the SHS unit (item 5).
<b>Installation method</b>	
Test Rig:	The test rig frame (item 5) was the main support for the test specimen. The specimen was fixed to the test rig via the aluminium framing (item 6). The SHS was also used at the false floor level. Steel studs (item 9) were also used at the false floor level.
External wall:	<p>The aluminium framing (item 6) consisted of extrusions around the perimeter and vertically down the centre of the wall sections. To the back of the aluminium framing was screw (item 20) fixed – at 200 mm centres around the perimeter – steel back-panels (item 4). Also to the aluminium framing were furring channel clips (item 8) – screw (item 17) fixed at ~1200 mm centres vertically. Slotted into the clips were steel furring channels (item 7). Within the furring channels polyester insulation (item 10) was fitted. Two layers of plasterboard (item 2) were screw (item 16) fixed to the back of the furring channels. Screw fixings were at 600 mm centres for the first layer and 200 mm to 300 mm centres.</p> <p>To the front face of the back-pan (item 4) was installed mineral wool insulation (item 11). ACP (item 1) was used to clad the majority of the front side of the aluminium framing (item 6). The ACPs (item 1) were “glazed in” the aluminium framing inside grooves and behind aluminium beads. The perimeter of the visible ACP and aluminium framing was sealed with a 10 mm bead of sealant (item 12).</p>
Balcony:	At the false floor level, a balcony structure was created. Details of this are shown in Appendix A. The balcony consisted of the horizontal member of the test rig (item 5) and steel framing (item 9). The steel false floor was capped with 2 layers of “non-combustible” cladding board (item 4). The boards were fixed to the steel substructure with self-drilling plasterboard screws (item 16) - at 500 mm centres.
Wall base:	The base of the walls - at the floor junction – consisted of an aluminium sill (item 20) fixed upon a cladding board (item 4) protected SHS unit (item 5).
For more details regarding the description of the specimen refer to Appendix A.	

### 3. Test procedure

Table 3 details the test procedure for this reaction to fire test.

**Table 3 Test procedure**

Item	Detail	
Statement of compliance	The ad-hoc test – which was based off ISO 13785-1:2002 - was performed to determine the reaction to fire performance of an external wall cladding when exposed to heat from a simulated external fire with flames impinging directly upon a façade. The test utilises a burner used in ISO 13785-1:2002 with the specimen mimicking the as-is construction of the façade.	
Sampling / specimen selection	The laboratory was not involved in sampling or selecting the test specimen for the reaction to fire test. The results obtained during the test only apply to the test samples as received and tested by Warringtonfire.	
Test duration	60 minutes	
Ambient laboratory temperature	Start of the test	27 °C
Instrumentation and equipment	<ul style="list-style-type: none"> <li>• Twelve mineral insulated metal sheathed (MIMS) Type K thermocouples with an overall diameter of 1.5 mm with the measuring junction insulated from the sheath were positioned at various positions 50 mm away from the specimen. These locations are shown in Figure 1 and Figure 2.</li> <li>• Six mineral insulated metal sheathed (MIMS) Type K thermocouples with an overall diameter of 1.5 mm with the measuring junction insulated from the sheath were positioned inside the specimen at the centre of the cavity. These locations are shown in Figure 1 and Figure 2.</li> <li>• The incident heat flux on the top of the specimen and the front face of the balcony in line with the front faces of test specimen was measured using two Schmidt-Boelter type heat flux gauge with a range of 0-100 kW/m<sup>2</sup>.</li> <li>• Two plates with mineral insulated metal sheathed (MIMS) Type K thermocouples with an overall diameter of 1.5 mm with the measuring junction insulated from the sheath were positioned 50 mm away from the grills. These locations are shown in Figure 1 and Figure 2.</li> <li>• The fire source was a propane (95% purity) gas burner 1.2 m long × 0.1 m deep × 0.15 m tall. The burner was placed on the floor in front of the specimen.</li> </ul>	
Test procedure	<ul style="list-style-type: none"> <li>• At least two minutes of baseline data was collected prior to burner ignition. Temperature and heat flux data was collected at 5 s intervals.</li> <li>• The heat output from the burner was held at 300 kW for 30 minutes. The burner was then turned off and the specimen observed for a further 30 minutes.</li> <li>• The test was ended at 60 minutes after burner ignition.</li> </ul>	
Test number	<ul style="list-style-type: none"> <li>• Test one of a proposed four.</li> </ul>	
Variation between tests	<ul style="list-style-type: none"> <li>• Not applicable – as it was the first test.</li> </ul>	

## 4. Test measurements and results

The results from the tests are summarised below. Photographs of the specimen are included in Appendix B.

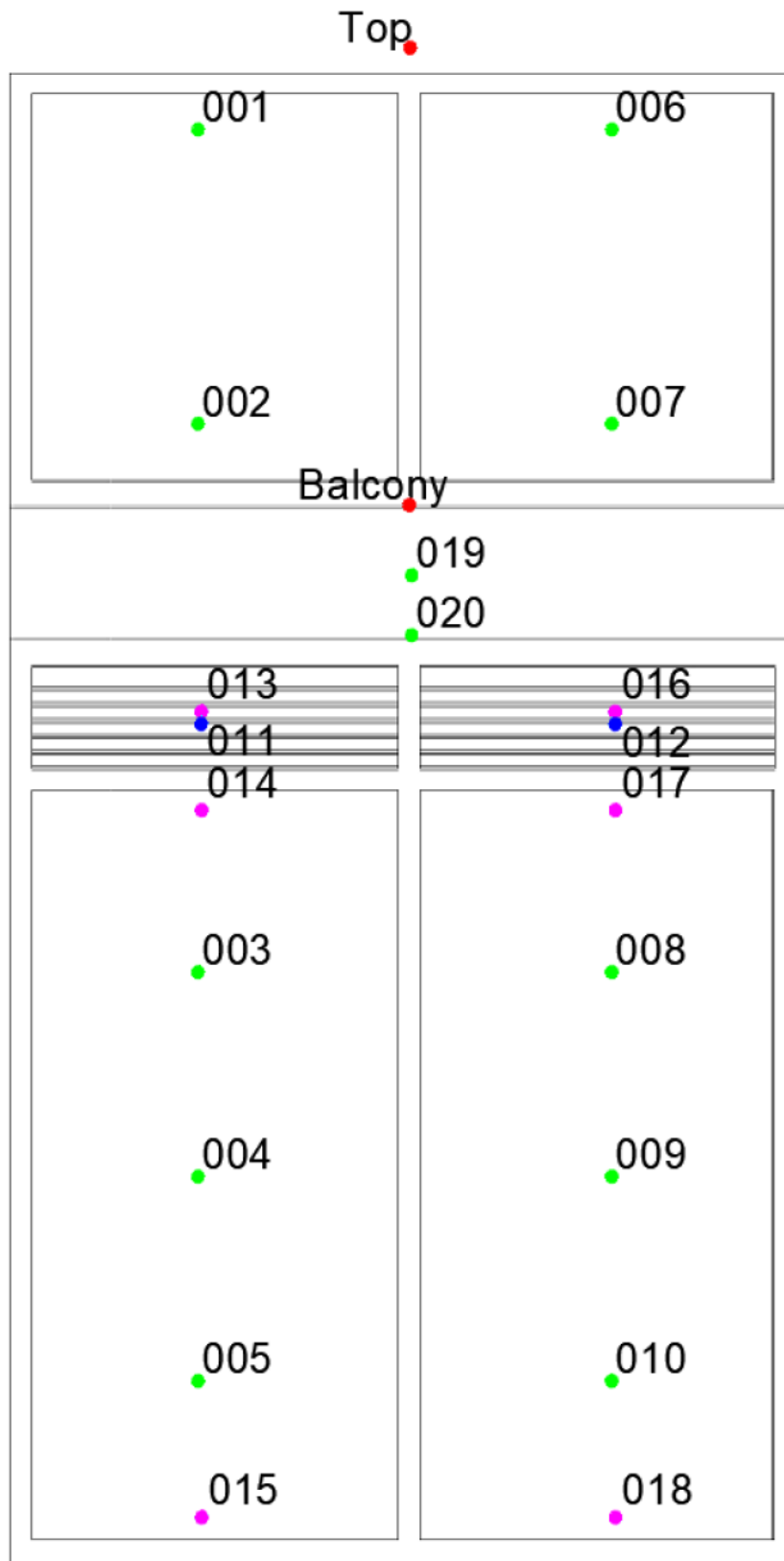

**Figure 1 Instrumentation positions – View from in front of specimen**

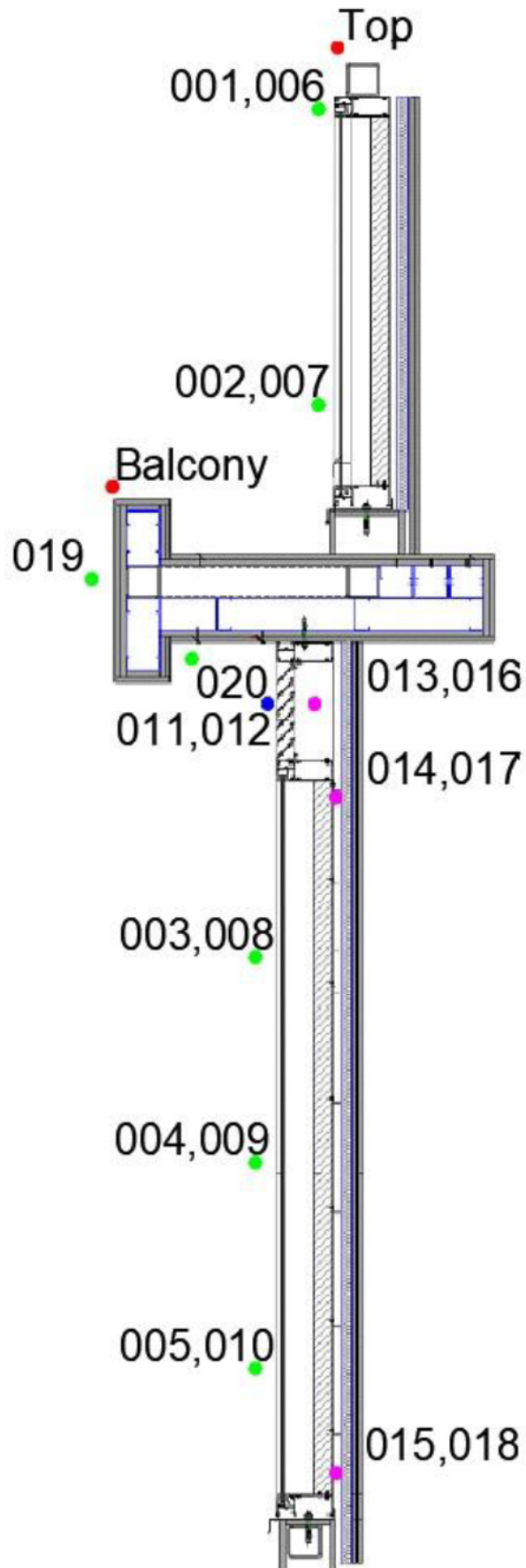

**Figure 2 Instrumentation positions – View from in front of specimen**

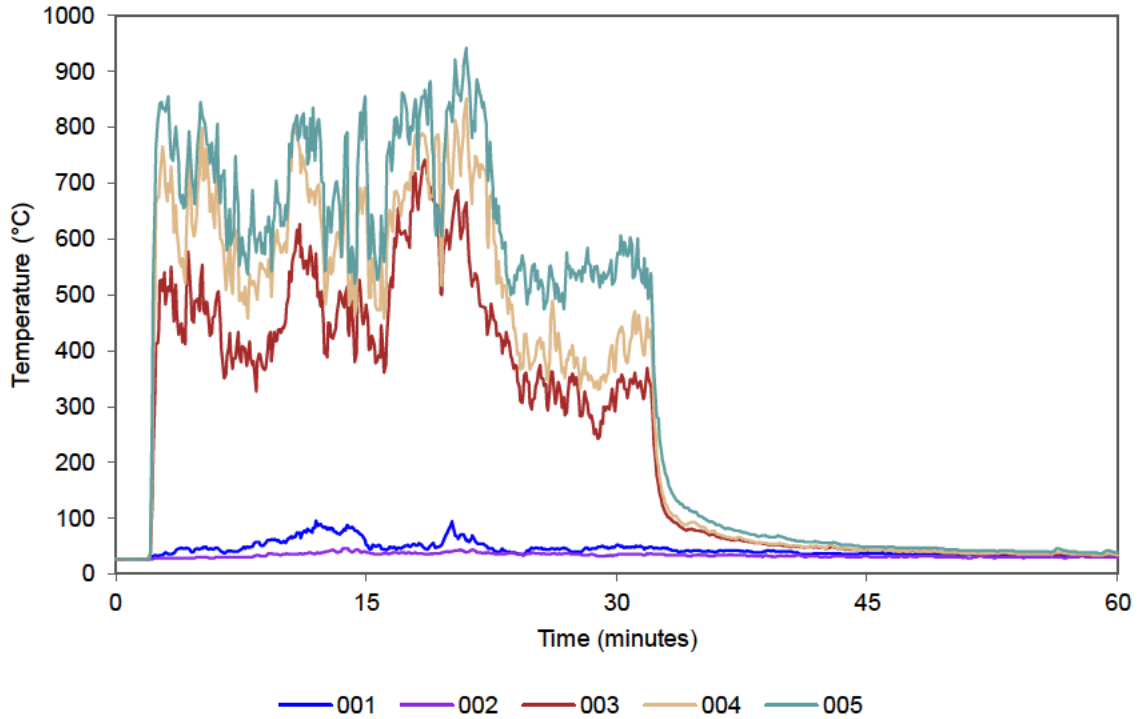

**Figure 3** External temperature data collected by thermocouples placed 50 mm from the front face of the specimen – East facade

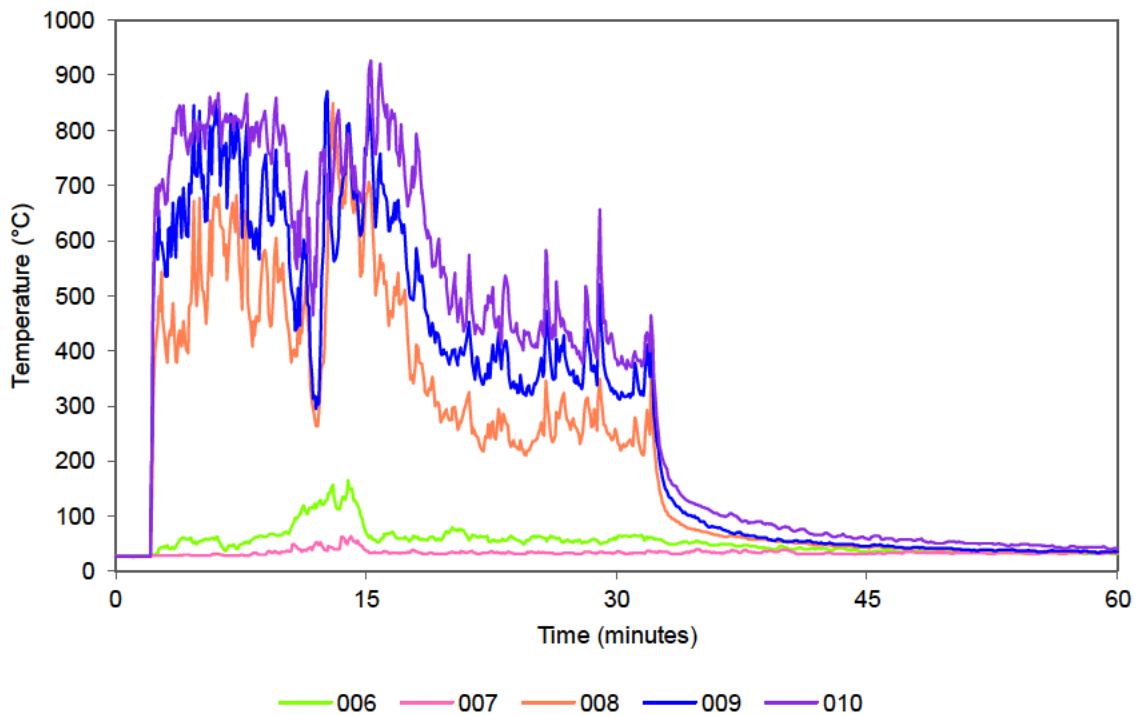

**Figure 4** External temperature data collected by thermocouples placed 50 mm from the front face of the specimen – West facade

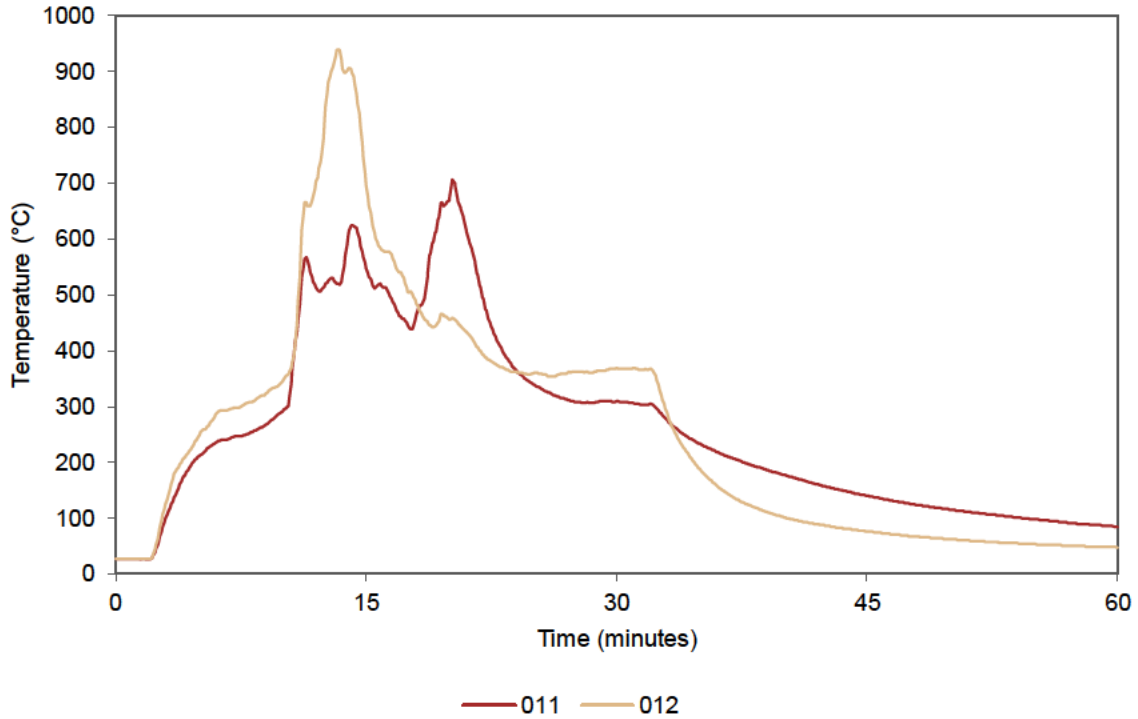

**Figure 5 External temperature data collected by plate thermocouples placed 50 mm from the front face of the specimen**

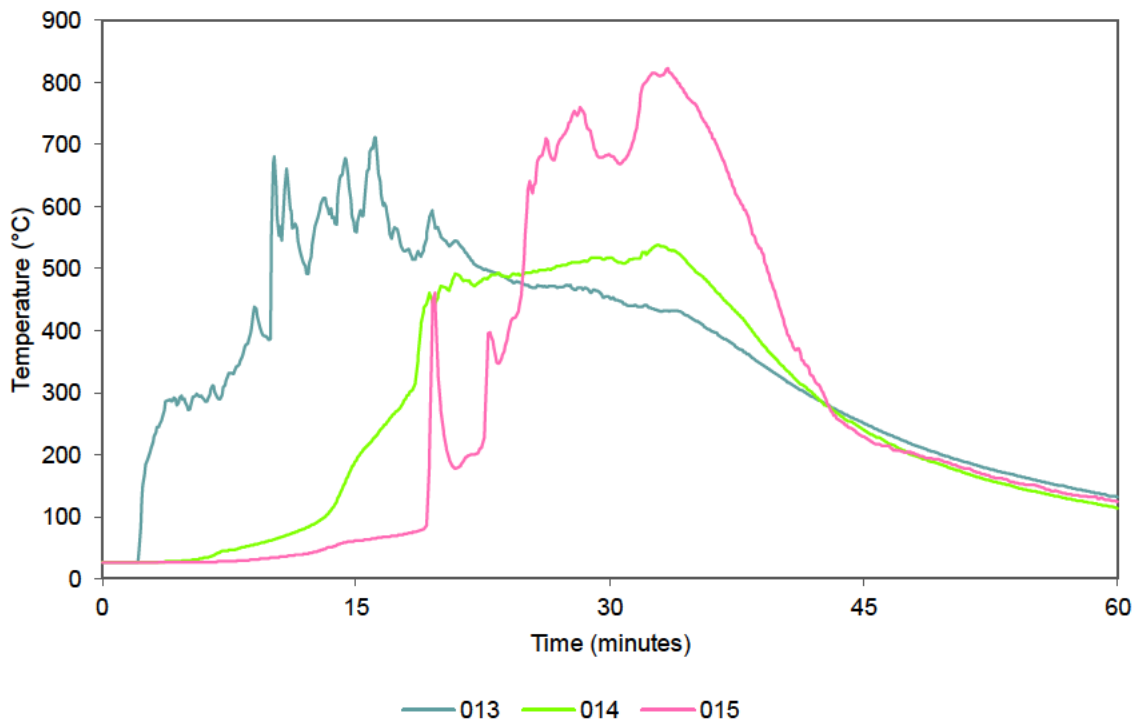

**Figure 6 Internal temperature data collected by thermocouples placed within the cavity – between the internal and external segments of the specimen – East façade**

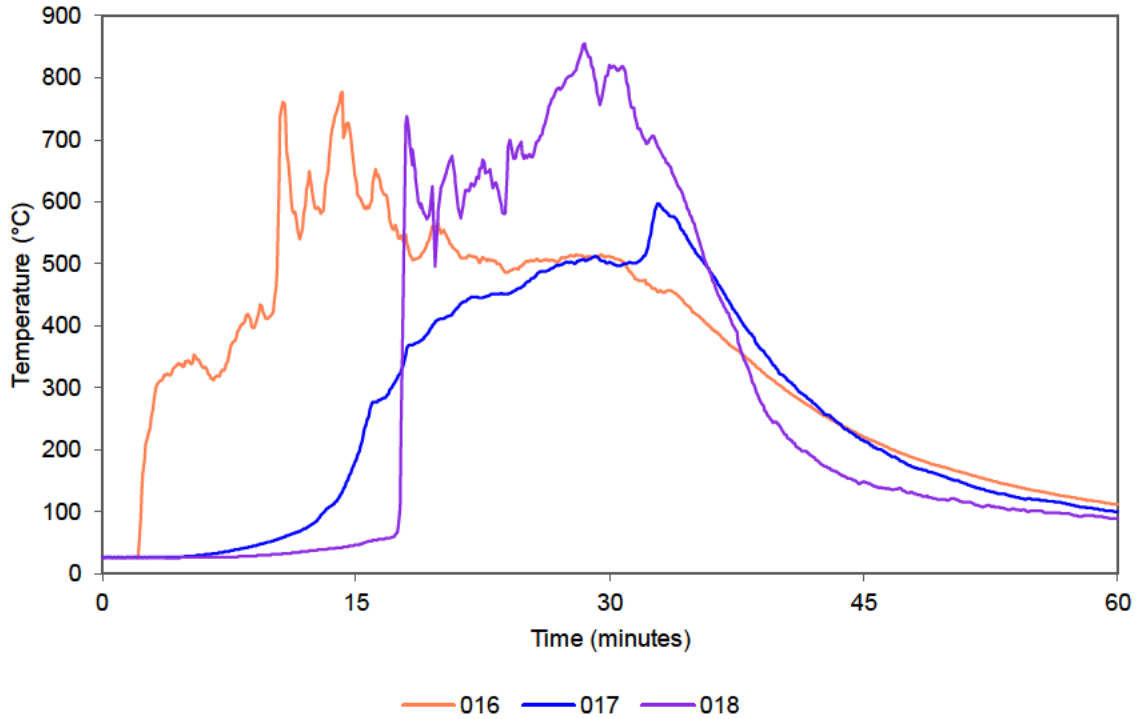

**Figure 7** Internal temperature data collected by thermocouples placed within the cavity – between the internal and external segments of the specimen – West façade

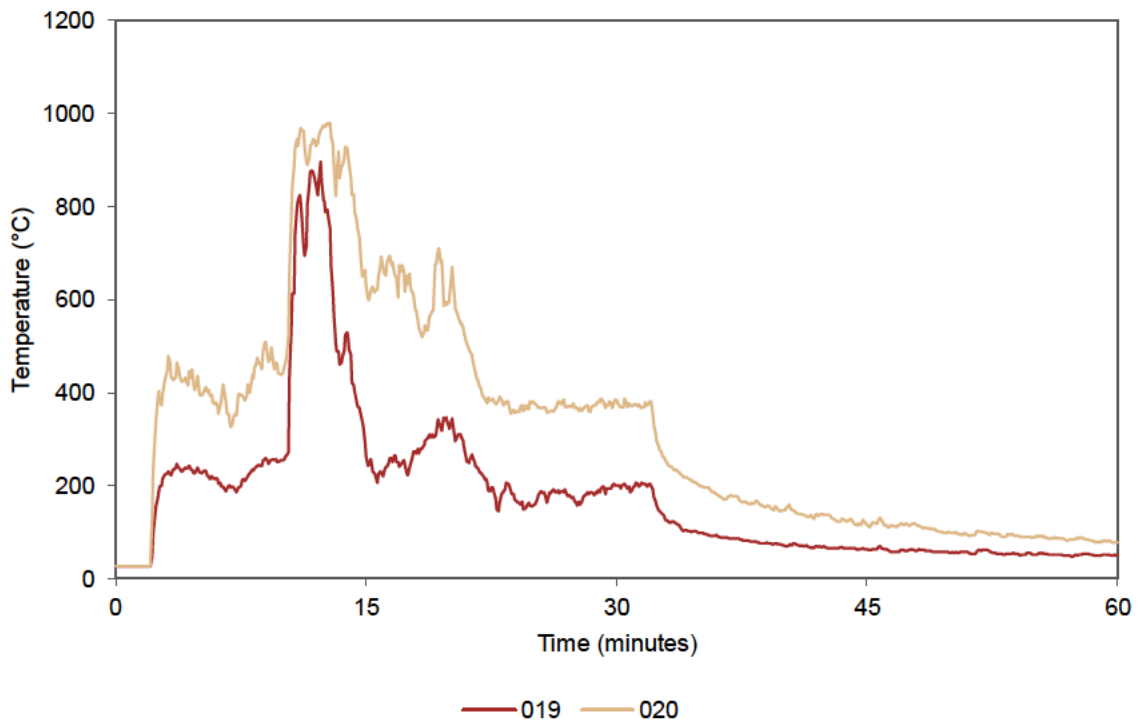

**Figure 8** External temperature data collected by thermocouples placed 50 mm from balcony face and underside cavity

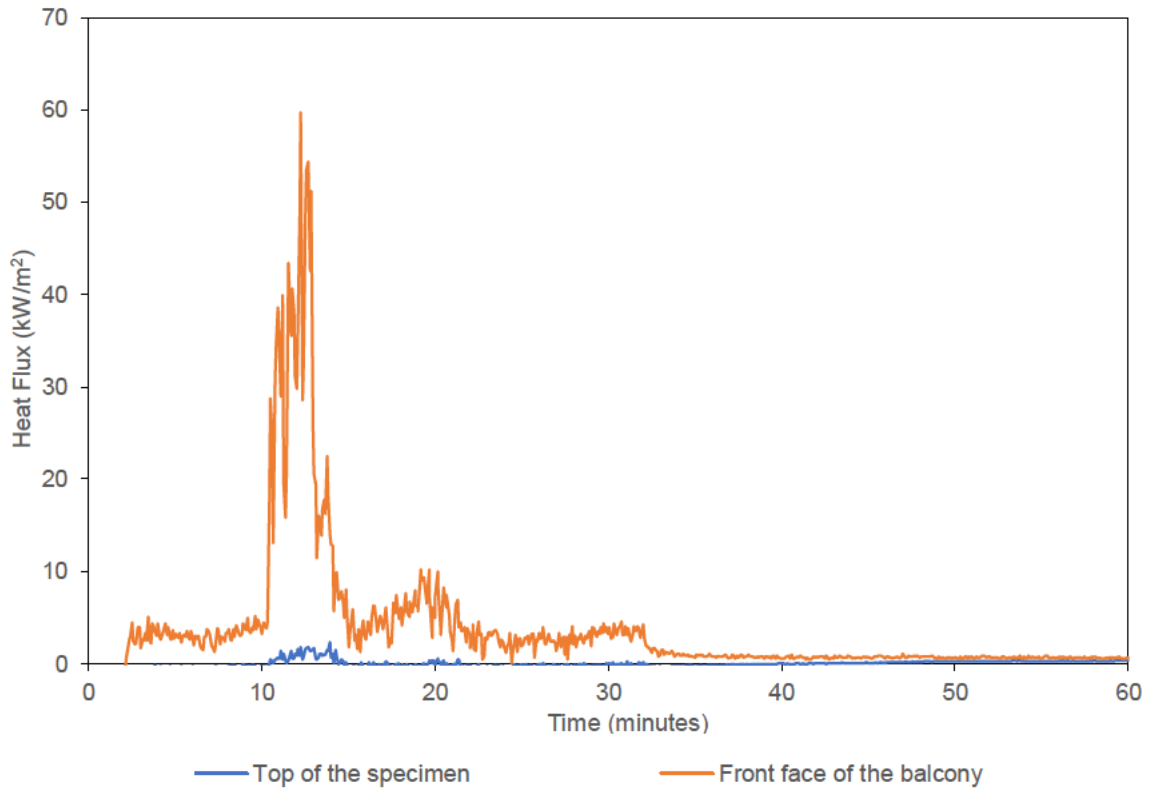

**Figure 9 Heat flux data collected by heat flux gauges**

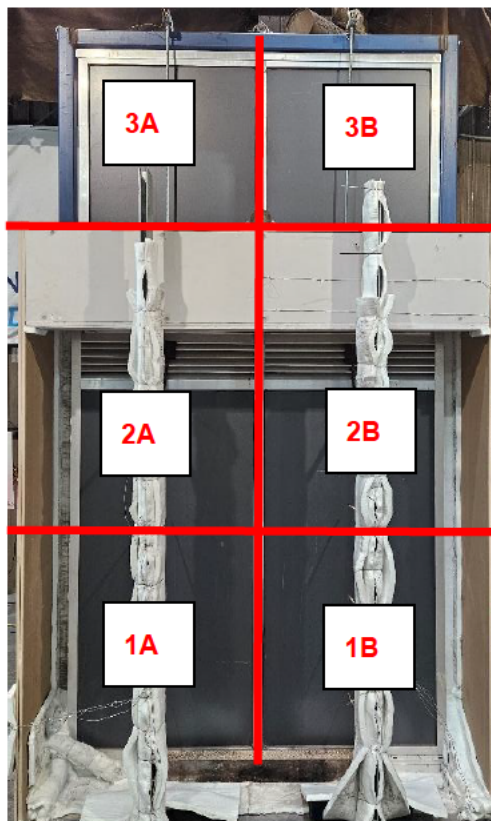

**Figure 10 Designation for test specimen observations**

Table 4 shows the observations of any significant behaviour of the specimen during the test.

Video recordings were also taken of the test. A copy of the video recording is available upon request from the test sponsor or by contacting Cladding Safety Victoria. The video of the test should be viewed in conjunction the contents of this report.

**Table 4 Test observations**

Time		Section	Observation
Min	Sec		
-2	00	All	Data collection started.
0	00	All	The reaction to fire test was started with the burner ignited to a 300 kW heat output.
0	29	2	The flames had reached the balcony underside.
0	52	2	Smoke started to emit from the panels.
1	07	1A/1B	The panels started to deform.
1	15	1A/1B	Debris started to fall from the panel faces.
1	44	2A/2B	Debris started to fall from the panel faces.
2	30	2A/2B	The panels started to deform.
2	50	2A/2B	The louvres started to deform.
3	21	2B	Intermittent flaming was observed at the top left corner.
4	36	2B	The flaming at the top left corner became sustained.
4	49	2A	Intermittent flaming was observed coming from behind the louvres.
5	48	2B	Sustained flaming was observed coming from behind the louvres.
7	24	2A/2B	Flames started to escape from the joint between 2A and 2B.
7	58	2A	The flames escaping from the louvres became sustained.
8	15	1/2	A buildup of gas was released from the specimen.
8	29	3	Flames had reached the top of the balcony front face.
8	47	2	The panels started to fall off, revealing the cavity behind.
11	19	2B	Most of the panel facing had detached.
12	02	2	Some molten debris started to fall from the louvres.
13	43	2A	The panel facing opened up at the top right corner.
14	50	2A/1A	The panel started to detach.
16	00	2B	The steel back pan started to deform.
16	40	2A	Molten debris started falling from the front panel.
17	30	2A	More molten debris fell from the panel.
17	36	2A	Flaming debris started to fall from the section.
20	30	All	The density of the smoke escaping from the specimen had increased.
25	00	1/2	Most of the back pan had deformed.
28	40	A/B	Flames started to escape from the middle joint.
30	00	All	The burner was turned off. Some independent flaming was still present.
33	33	A/B	Some independent flaming was still observed at the joint.
49	00	A/B	The flaming at the joint had died.
58	00	A/B	The smoke escaping from the west edge had died off.
60	00	All	The reaction to fire test was ended.

## **5. Application of test results**

### **5.1 Test limitations**

The results of these fire tests may be used to directly assess fire hazard, but it should be recognised that a single test method will not provide a full assessment of fire hazard under all fire conditions.

These results only relate to the behaviour of the specimen of the element of construction under the particular conditions of the test. They are not intended to be the sole criteria for assessing the potential fire performance of the element in use, and they do not necessarily reflect the actual behaviour in fires.

### **5.2 Variations from the tested specimen**

This report details methods of construction, the test conditions and the results obtained when the specific element of construction described here was tested following the procedure outlined in Table 3. Any significant variation with respect to size, construction details, loads, stresses, edge or end conditions is not addressed by this report.

It is recommended that any proposed variation to the tested configuration should be referred to the test sponsor. They should then obtain appropriate documentary evidence of compliance from Warringtonfire or another accredited testing authority.

### **5.3 Uncertainty of measurements**

Because of the nature of reaction to fire testing and the consequent difficulty in quantifying the uncertainty of measurements obtained from a reaction to fire test, it is not possible to provide a stated degree of accuracy of result.

## Appendix A Drawings of test assembly

The drawings of the test assembly in Figure 11 to Figure 12 were provided by representatives of Warringtonfire. Dimensions, unless specified, are in mm.

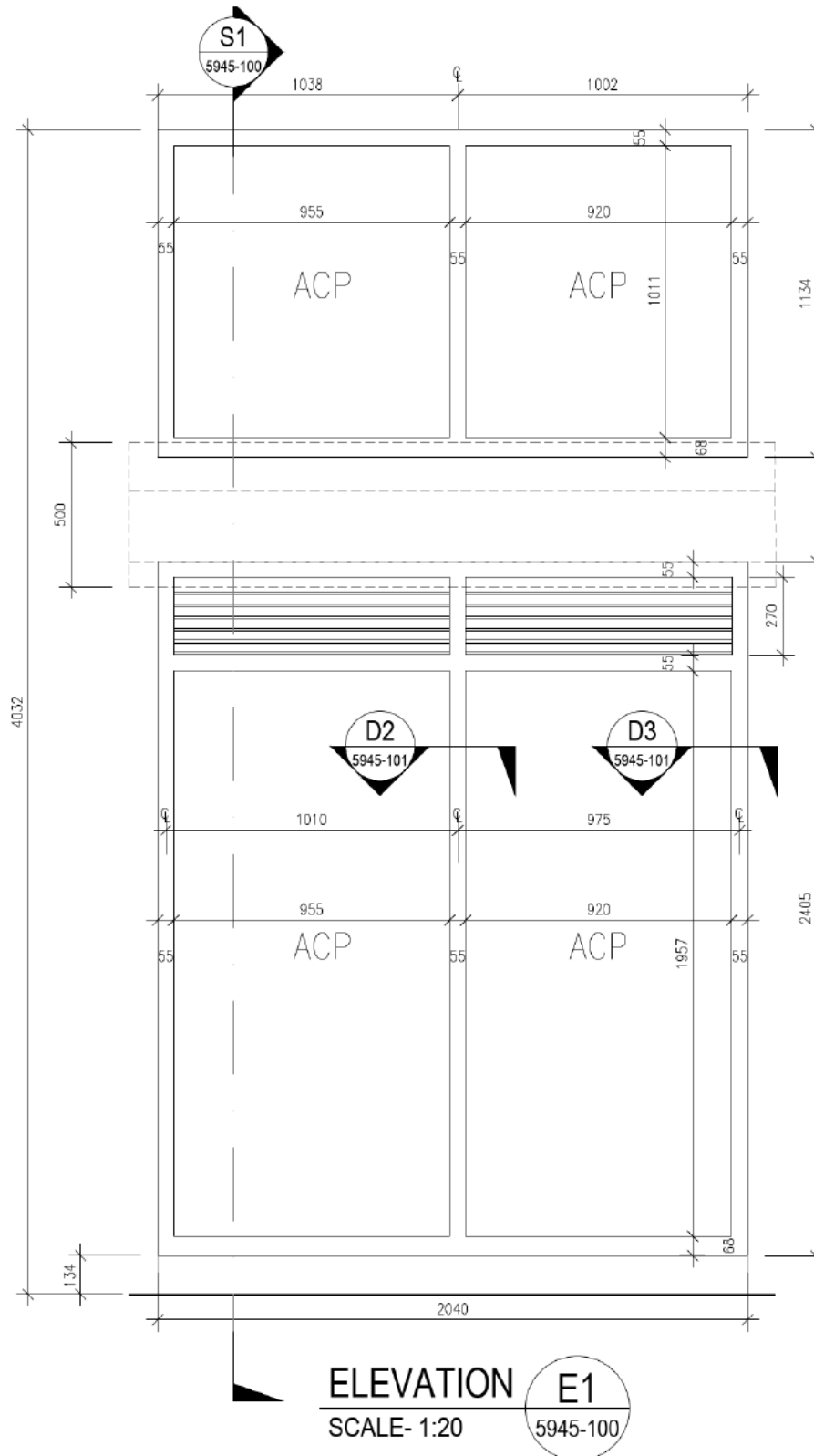

**Figure 11 Elevation of rig support.**

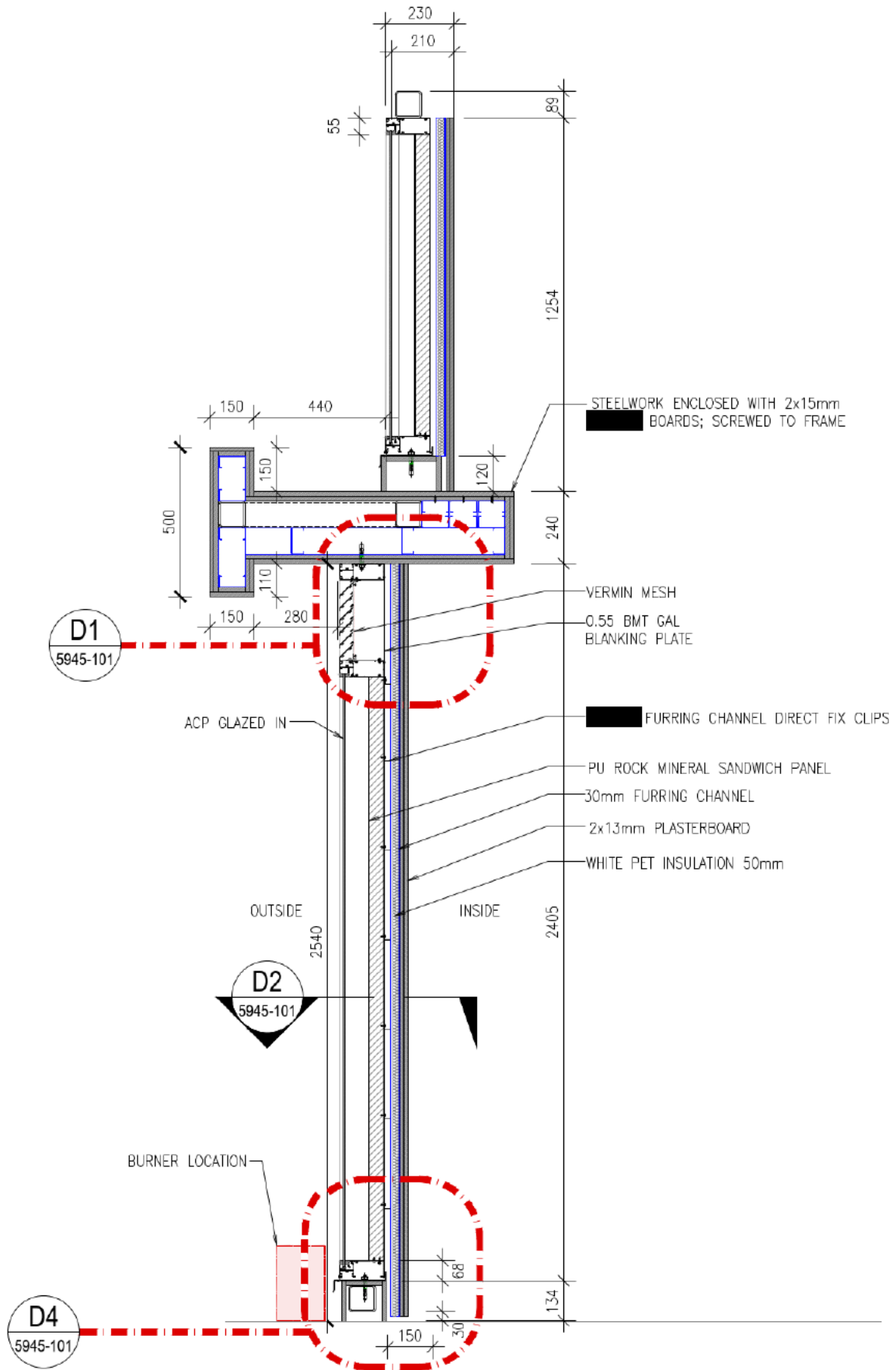

**Figure 12 System assembly – Front and side view**

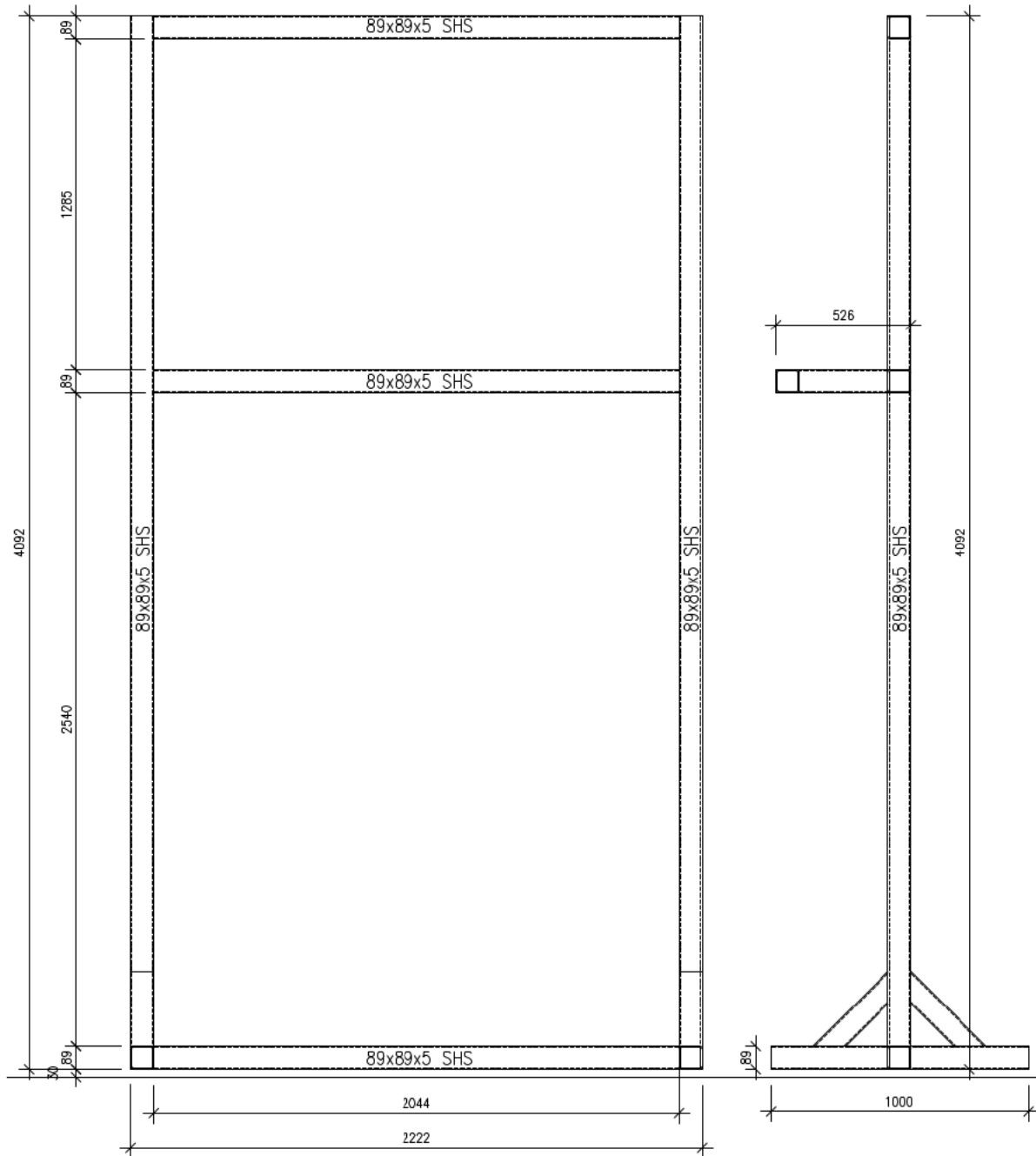

**Figure 13 System assembly – Test frame**

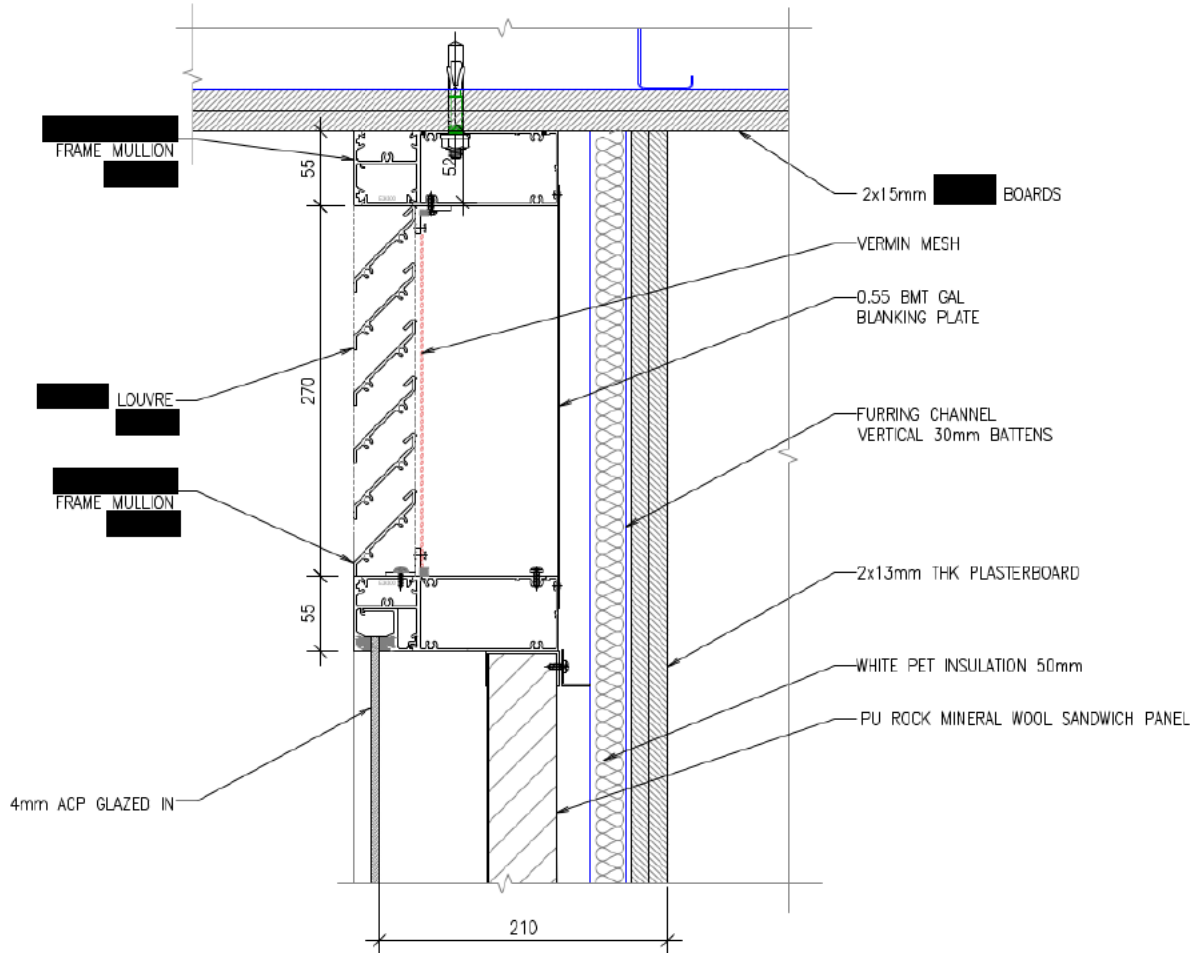

**Figure 14 System detail – Detail D1**

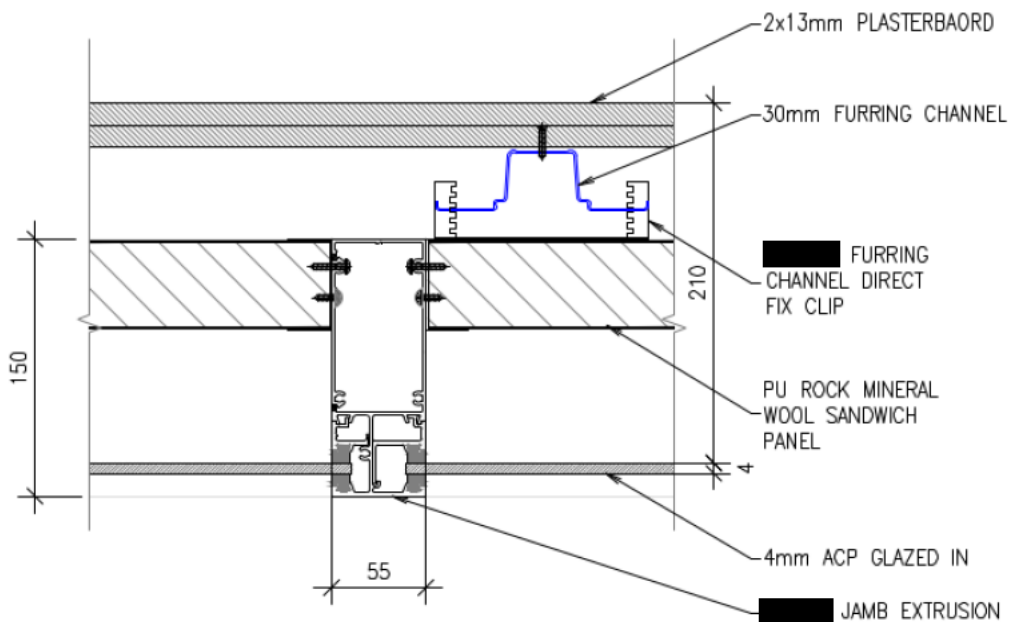

**Figure 15 System detail – Detail D2**

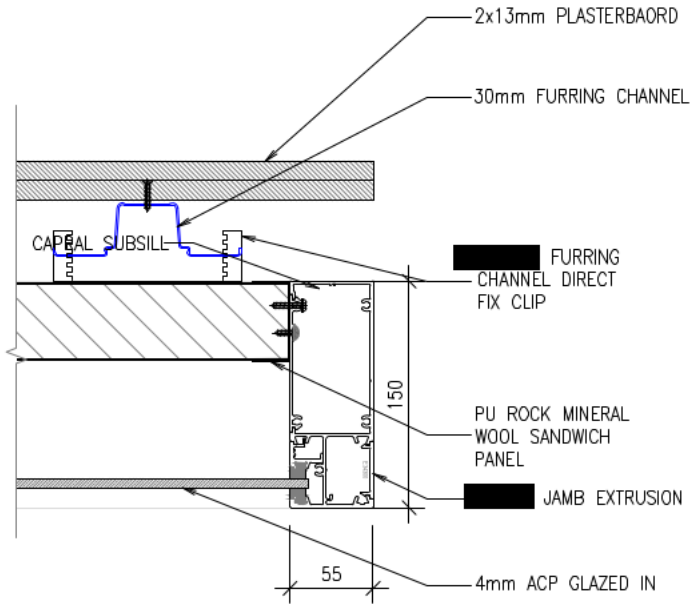

**Figure 16 System detail – Detail D3**

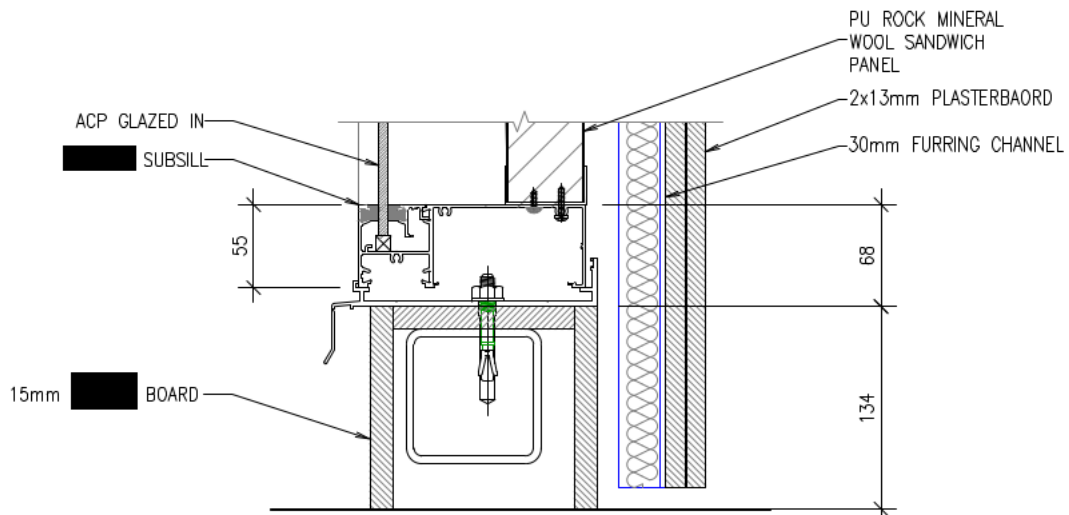

**Figure 17 System detail – Detail D4**

## Appendix B Photographs



**Figure 18** The specimen before the reaction to fire test



**Figure 19** The specimen before the reaction to fire test – unexposed side



**Figure 20** The specimen 1 minute into the test (burner output set to 300 kW for the duration of the test)

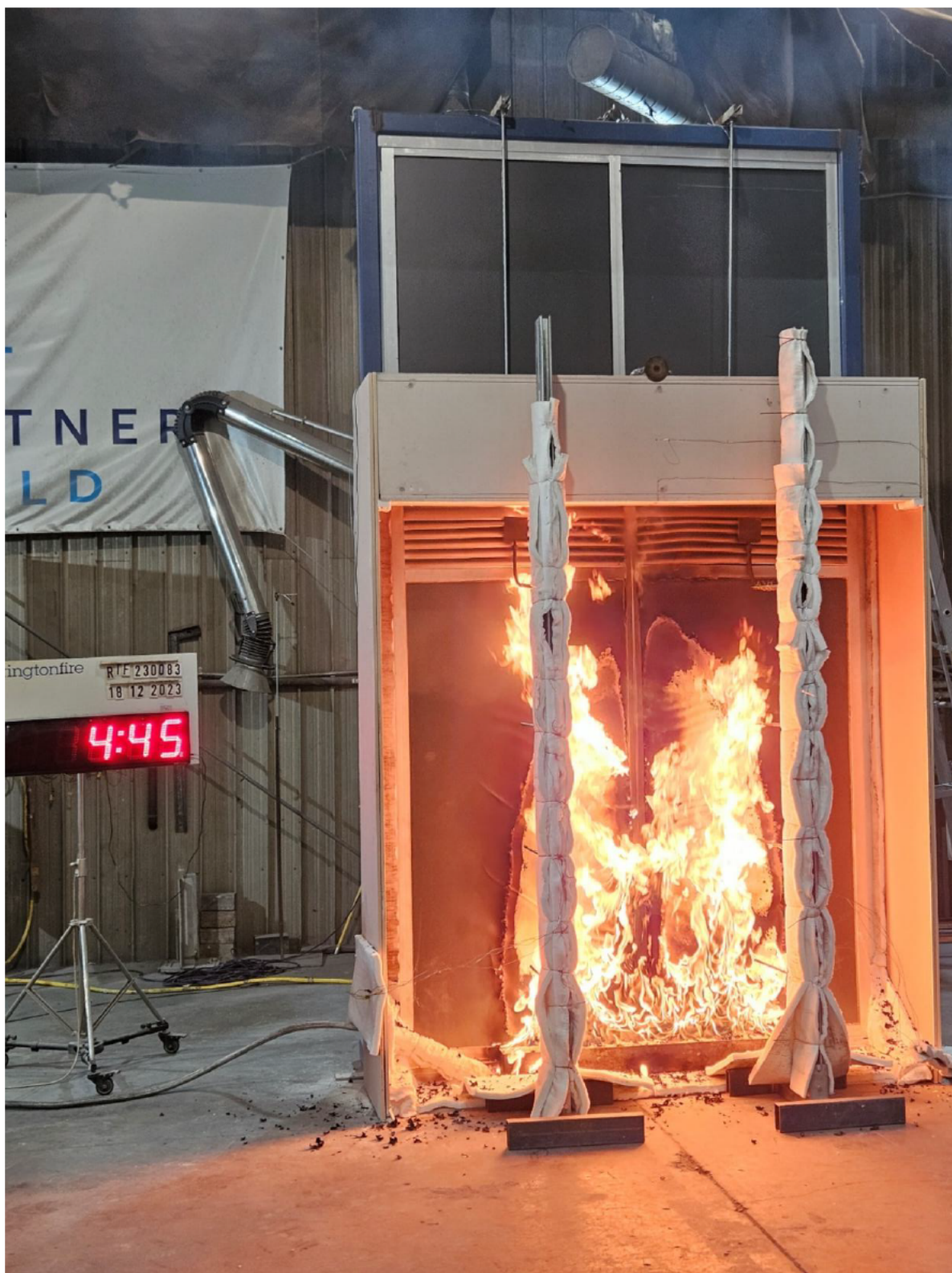

**Figure 21 The specimen 4 minutes 45 seconds into the test**



**Figure 22** The specimen 10 minutes into the test



**Figure 23 The specimen 14 minutes 51 seconds into the test**



**Figure 24** The specimen 20 minutes into the test



**Figure 25** The specimen 29 minutes into the test



**Figure 26** The specimen 10 seconds after the burner was turned off (30 minutes 10 seconds into the test)



**Figure 27** The specimen after the test.



**Figure 28 The specimen after the test – unexposed side.**

## Appendix C Chemical Analysis Results



### Cladding Safety Victoria – Building Façade Material Laboratory Analysis Report

<b>CETEC Project Reference:</b>	P23070102.0006
<b>Client Project Reference:</b>	██████_B187
<b>Engaged By:</b>	██████████
<b>Company:</b>	Cladding Safety Victoria
<b>Company Address:</b>	Level 4, Mayfield Place, South Podium Office, 717 Bourke St, Docklands VIC 3008
<b>Site Address:</b>	1 Palmer Street, Richmond VIC 3121
<b>Sample Collected By:</b>	Client
<b>Date Sample received:</b>	25/10/2023
<b>Version:</b>	1.0

Prepared By:



CETEC Pty Ltd  
Unit 2/27, Normanby Road  
Notting Hill, VIC 3168

Prepared For:



Cladding Safety Victoria

**CETEC Pty Ltd** ABN: 44 006 873 687 [www.cetec.com.au](http://www.cetec.com.au)

Melbourne | Sydney | Brisbane | Perth | London | San Francisco



<b>PROJECT: Building Façade Material Laboratory Analysis Report</b>		<b>REPORT COMMISSIONED BY:</b> [REDACTED] from Cladding Safety Victoria		
<b>CETEC Pty Ltd</b> 2/27 Normanby Rd, Notting Hill VIC 3168				
<b>CETEC REF: P23070102.0006</b>		<b>CLIENT Ref: [REDACTED]_B187</b>		<b>VERSION: 1.0</b>
AMD	DESCRIPTION	INT	REVIEWED	DATE
1.0	Building façade system testing results for samples sent by Client	DP	MD/PDS/VG	26/10/2023

**Authors:**



Senior Consultant

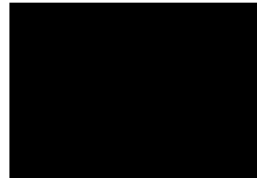

Lead Consultant

**Reviewers:**



Principal Consultant - Dangerous Goods

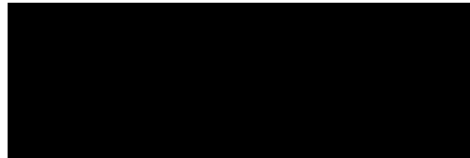

Managing Director and Principal Consultant



## CONTENTS

<b>1. INTRODUCTION</b> .....	4
<b>1.1. SCOPE OF WORK</b> .....	4
<b>1.2. LIMITATIONS</b> .....	4
<b>2. TESTING METHODOLOGY</b> .....	4
<b>2.1. SAMPLE PREPARATION</b> .....	6
<b>2.2. CHEMICAL COMPOSITION BY ATR-FTIR</b> .....	6
<b>2.3. FUEL LOAD AND FILLER CONTENT BY DRY OXIDATIVE ASHING</b> .....	6
<b>3. LABORATORY RESULTS</b> .....	7
<b>3.1. SPECTRAL ANALYSIS BY ATR-FTIR</b> .....	7
<b>3.2. DRY OXIDATIVE ASHING TEST</b> .....	8
<b>4. DISCUSSION OF RESULTS</b> .....	9
<b>4.1. ATR-FTIR</b> .....	9
<b>4.2. OXIDATIVE DRY-ASHING</b> .....	10
<b>5. CONCLUSION</b> .....	11
<b>APPENDIX A : PHOTOGRAPHIC RECORD OF BUILDING FAÇADE SYSTEM SAMPLES</b> .....	13
<b>DISCLAIMER</b> .....	15
<b>COPYRIGHT</b> .....	15



## 1. INTRODUCTION

### 1.1. SCOPE OF WORK

CETEC Pty Ltd was engaged by [REDACTED] from Cladding Safety Victoria to conduct laboratory analysis of building façade system samples to determine the composition. Details of the building façade system material, as received from the client on the 25/10/2023, and subjected to laboratory analysis by Foray Laboratories, a company wholly owned by CETEC Pty Ltd, are recorded below in Table 1.

### 1.2. LIMITATIONS

Laboratory results and discussions as detailed within this document should not be used in isolation and are to be used by fire engineers to assist stakeholders, such as building owners, building managers, and building insurers in providing advice relating to the building's façade system flammability potential, composition, and toxicity. This document is not to be used as a substitute to regulatory testing requirements or the AS 1530 series of standards as well as full-scale evaluation to the new AS 5113 tests for external wall as the methodology adopted by CETEC is only to determine the material composition and preliminary information on the materials only.

## 2. TESTING METHODOLOGY

Each sample was analysed by Foray Laboratories, a company wholly owned by CETEC Pty Ltd, incorporating product descriptions as detailed below in Table 1. Each sample, as received, was registered into the Foray Laboratory sample registration system to conform to NATA ISO 17025 requirements. The Foray Laboratory sample number and description of each sample are given in Table 1.



**Table 1: Building Façade Material Samples Received and Laboratory Analysis the Samples Were Subjected To.**

Sample ID	Sample Type <sup>1</sup>	Client Sample Description / Location of Collected Sample <sup>2</sup>	Laboratory Analysis Conducted							Appendix A
			ATR-FTIR	Oxidative Dry Ashing	Micro-flammability	Thermal Stability	TGA	X-Ray Fluorescence	X-Ray Diffraction	
164883	ACP	ACP Grey	✓	✓	x	x	x	x	x	Photo 2
164884	ACP	ACP Copper	✓	✓	x	x	x	x	x	Photo 3

<sup>1</sup> ACP – Aluminium Composite Panel, SMP – Sheet Metal Panel, FCP – Fibre Cement Panel.

<sup>2</sup> Samples analysed by Foray Laboratories as received.

# CETEC

## 2.1. SAMPLE PREPARATION

The building façade material was cut into portions and each portion was subjected to scientific analysis *via* the following laboratory methods.

- Attenuated Total Reflection Fourier Transform Infrared Spectroscopy (ATR-FTIR).
- Dry Ashing Testing.

## 2.2. CHEMICAL COMPOSITION BY ATR-FTIR

Attenuated Total Reflection (ATR) is a sampling technique used in conjunction with Infrared Spectroscopy which enables samples to be examined directly in the solid or liquid state without further sample preparation. The technique is used to obtain an infrared spectrum of absorption or emission of a solid or liquid and the spectral data which is generated can easily identify functional groups within the sample which makes it possible to infer composition of both polymer and inorganic or mineral filler. That is, analysis of the Functional Group Region of the spectra (i.e., 4000  $\text{cm}^{-1}$  to 1450  $\text{cm}^{-1}$ ) makes it possible to observe functional groups that are present within the material which aids in the identification of the polymer and filler present. Further to this, comparison to known samples aids in the identification and confirmation of the type of building façade material.

## 2.3. FUEL LOAD AND FILLER CONTENT BY DRY OXIDATIVE ASHING

A weighed sample was heated within a muffle furnace under an oxidative atmosphere to convert all common oxidisable organic material, such as polymers and plasticisers, to carbon dioxide and other gaseous products, e.g., carbon monoxide. All common inorganic non-combustible fillers are generally dehydrated and converted to their common oxides which forms the non-combustible ash residue. When this method is coupled with FTIR spectral identification and calculation, the quantitative proportion of filler and organic materials (including polymer, plasticisers, etc.) can be assessed based on the amount of collected ash. The calculated inert filler is based on the assumption that the identified filler within the ATR-FTIR is present with no to little impurities which may be below the detection limit of the ATR-FTIR method. Thermal Gravimetric Analysis Differential Scanning Calorimetry (TGA-DSC) in conjunction with Dry Ashing can be used with quantitative assessment of combustible to non-combustible material to ascertain polymer content to non-polymer content

# CETEC

## 3. LABORATORY RESULTS

### 3.1. SPECTRAL ANALYSIS BY ATR-FTIR

A summary of building façade system samples subjected to ATR-FTIR are shown in Table 2 with reference to subsequent figures.

**Table 2: Building façade system sample subjected to FTIR Analysis.**

Sample ID	Sample Type	Core Colour	ATR-FTIR Spectra
164883	ACP	Black	Figure 1
164884	ACP	Black	Figure 2

**Figure 1: Sample 164883 - FTIR of Building Façade System.**

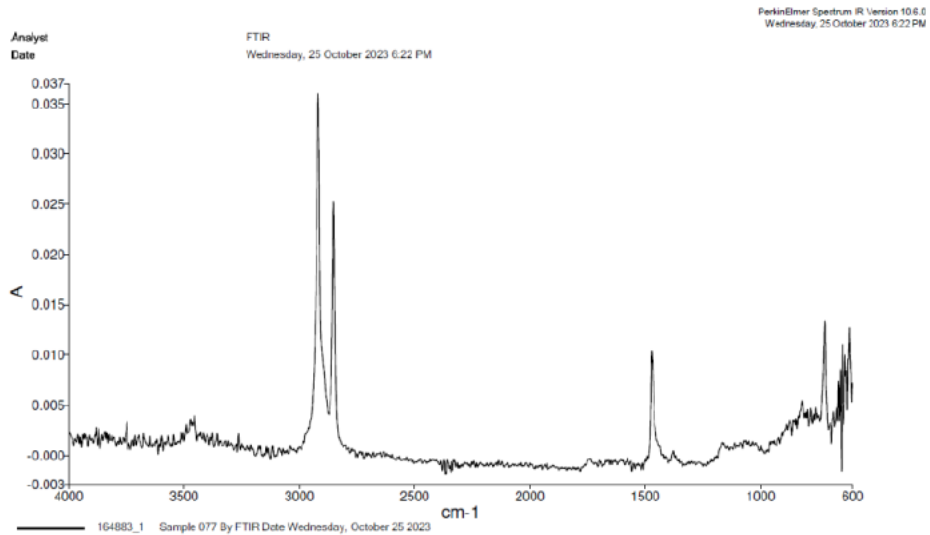



**Figure 2: Sample 164884 - FTIR of Building Façade System.**

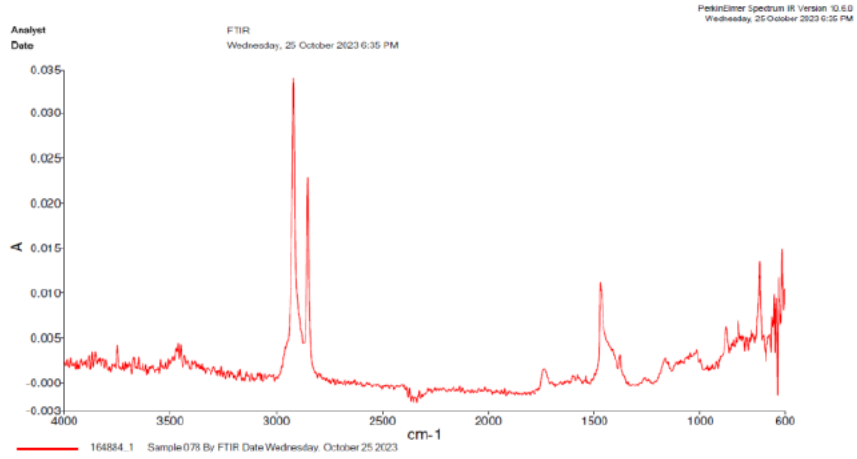

### 3.2. DRY OXIDATIVE ASHING TEST

A summary of building façade system samples subjected to Dry-Ashing with results are summarised in Table 3.

**Table 3: Building façade system sample dry oxidative ashing results.**

Sample ID	Sample Type	Mass of Sample <sup>3</sup> (g)	Ash <sup>4</sup> (g)	Appearance of Ash
164883	ACP	0.06	0	No ash
164884	ACP	0.0727	0.0048	Brown ash

<sup>3</sup> Mass of polymer core sample subjected to ashing.

<sup>4</sup> Mass of ash remaining after ashing experiment.

# CETEC

## 4. DISCUSSION OF RESULTS

### 4.1. ATR-FTIR

Analysis of the FTIR spectra *via* a library search of known polymer blends identified the following possible polymer blend corresponding to the analysed samples in Table 2. This information is further summarised in Table 4 with their corresponding library match and figure.

**Table 4: Building façade system sample composition identification.**

Sample ID	Sample Type	Core Colour	Identified Major Components by FTIR	Figure
164883	ACP	Black	Polyethylene with no filler	Figure 3
164884	ACP	Black	Polyethylene with unidentified filler	Figure 4

**Figure 3: - FTIR Spectral Comparisons of Known Material with Sample 164883.**

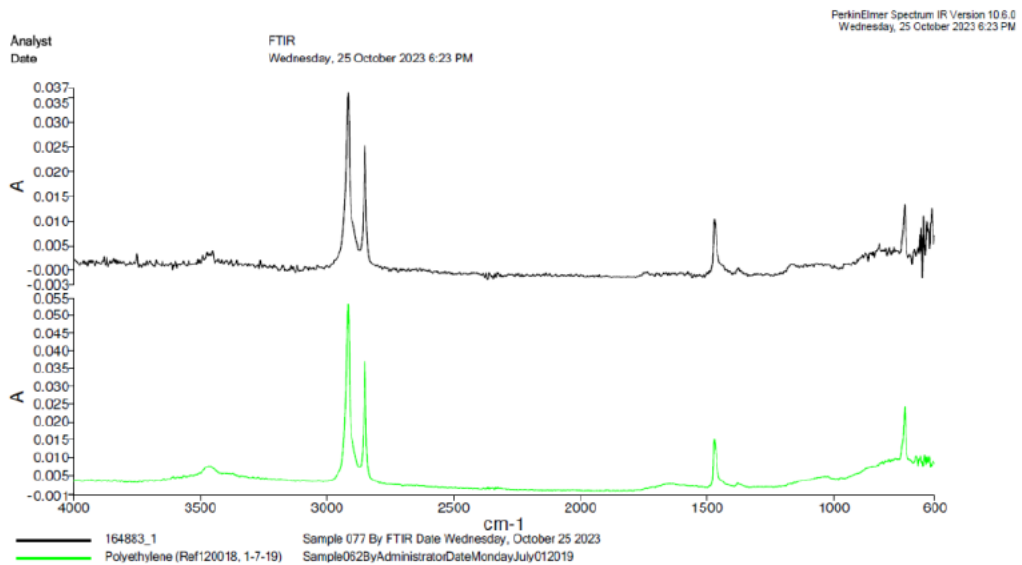



**Figure 4: - FTIR Spectral Comparisons of Known Material with Sample 164884.**

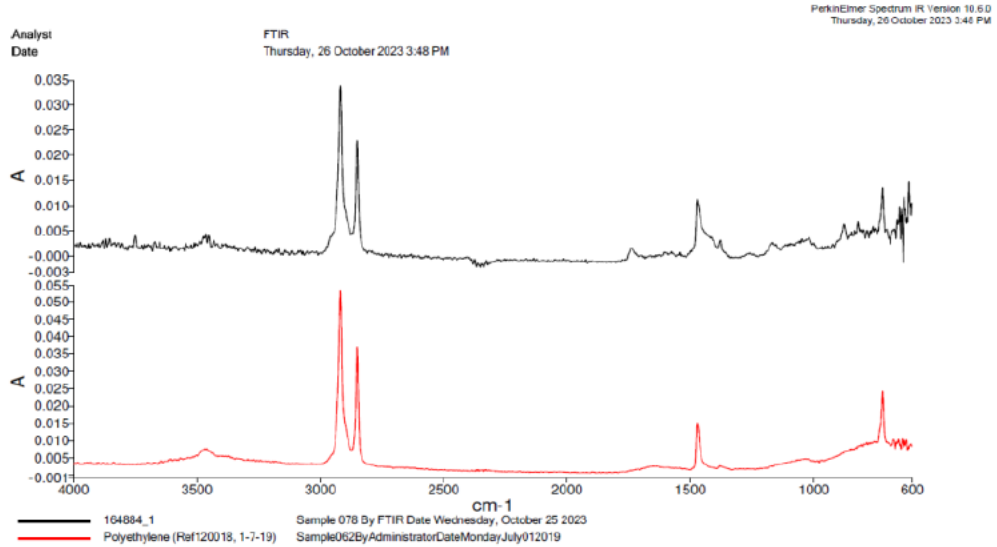

**4.2. OXIDATIVE DRY-ASHING**

The oxidative dry-ashing results of the building façade samples are summarised in Table 5 for the samples analysed.

**Table 5: Identified building façade system sample dry-ashing results.**

Sample ID	Sample Type	Identified Composition by FTIR	Calculated Filler Material (w/w%)	Calculated Combustible Material (w/w%)
164883	ACP	Polyethylene with no filler	0%	100%
164884	ACP	Polyethylene with unidentified filler	12%	88%



## 5. CONCLUSION

On behalf of [REDACTED] from Cladding Safety Victoria, CETEC conducted scientific analysis of building façade system samples to determine their composition. The samples were analysed, as received by CETEC on 25/10/2023 and sent to Foray Laboratories, a NATA registered company wholly owned by CETEC for scientific analysis of the samples.

Testing following methodology developed by CETEC Pty Ltd to determine composition and a summary of results is detailed below in Table 6 with an additional photographic summary of the samples received (refer to Appendix A).



Table 6: Laboratory Analysis summary.

Sample ID	Sample Type	Client Sample Description	Core Colour	Identified Composition <sup>5</sup>	Calculated Filler Material (w/w%)	Calculated Combustible Material (w/w%)
164883	ACP	ACP Grey	Black	Polyethylene with no filler	0%	100%
164884	ACP	ACP Copper	Black	Polyethylene with unidentified filler	12%	88%

<sup>5</sup> Analysis by FTIR



# CETEC



**Photo 3, Sample 164884 as received.**

# CETEC

## DISCLAIMER

CETEC has taken all reasonable care to ensure that the information contained in this report is accurate. The report is based on data and information collected by CETEC personnel during location visits and information accepted in good faith from various personnel associated with this work. However, no warranty or representation can be given that the information and materials contained in it are complete or free from errors or inaccuracies.

CETEC accepts no responsibility for any deficiency, misstatements or inaccuracies contained in this report as a result of omissions, misinterpretation or fraudulent acts of the persons interviewed or contacted.

To the extent permitted by applicable laws, CETEC accepts no liability for any decision, action, loss, damages, or expenses of any kind including without limitation, compensatory, direct, indirect, or consequential damages, loss of data, income or profit, loss of or damage to property, or claims by third parties howsoever arising in connection with the use or reliance on the information in this report. This exclusion of liability shall also apply to damages arising from death or personal injury potentially caused by the negligence of CETEC or any of its employees or agents.

CETEC has not made any determination if these products are in compliance with the National Construction Code. Further to this, this report cannot be used as evidence unless the client agrees to reimburse CETEC at hourly rates for any involvement in legal proceedings.

By viewing this report, you are acknowledging that you have read and agree to the above disclaimer.

## COPYRIGHT

The material in this report is protected by copyright, which is owned by CETEC. Users may view, print, and download the contents for personal use only and the contents must not be used for any commercial purposes, without the express permission of Cladding Safety Victoria and CETEC. Furthermore, the material in this report, or any part of it, is not to be incorporated or distributed in any work or in any publication in any form without the permission of Cladding Safety Victoria and CETEC.



# WARRINGTONFIRE AUSTRALIA

A Jensen Hughes Company

Warringtonfire Australia Pty Ltd  
ABN 81 050 241 524

## Perth

Suite 4.01, 256 Adelaide Terrace  
Perth WA 6000  
Australia  
T: +61 8 9382 3844

## Canberra

Unit 10, 71 Leichhardt Street  
Kingston ACT 2604  
Australia  
T: +61 2 6260 8488

## Melbourne

Level 4, 152 Elizabeth Street  
Melbourne Vic 3000  
Australia  
T: +61 3 9767 1000

## Sydney

Suite 302, Level 3, 151 Castlereagh Street  
Sydney NSW 2000  
Australia  
T: +61 2 9411 5360

## Brisbane

Suite B, Level 6, 133 Mary Street  
Brisbane Qld 4000  
Australia  
T: +61 7 3238 1700

## Melbourne – NATA accredited laboratory

409-411 Hammond Road  
Dandenong South Vic 3175  
Australia  
T: +61 3 9767 1000

## General conditions of use

The data, methodologies, calculations and results documented in this report specifically relate to the tested specimen/s and must not be used for any other purpose. This report may only be reproduced in full. Extracts or abridgements must not be published without permission from Warringtonfire.

All work and services carried out by Warringtonfire are subject to, and conducted in accordance with our standard terms and conditions.