



JENSEN HUGHES



Reaction to fire test report

Test standard: BS 8414-2:2015

Test sponsor: Cladding Safe Victoria

Product: Aluminium composite panel façade

Job number: RTF120854

Test date: 19 December 2024 Revision: RR1.0



Quality management

Revision	Date	Information about the report			
RR1.0	26 November 2025	Description	Initial issue.		
			Prepared by	Reviewed by	Authorised by
		Name	██████████	██████████	██████████
		Signature			

Jensen Hughes Fire Testing Pty Ltd
ABN 81 050 241 524

Formerly Warringtonfire Australia Pty Ltd¹

¹ Warringtonfire Australia Pty Ltd was acquired by Jensen Hughes in December 2023. Jensen Hughes Fire Testing Pty Ltd is not affiliated, associated, authorised, or endorsed by Warringtonfire Australia Pty Ltd, Warringtonfire Testing and Certification Limited or its "Warringtonfire" or "Certifire" brands.

Executive summary

This report documents the findings of the reaction to fire test for a non-loadbearing external wall system performed on 19 December 2024 in general accordance with BS 8414-2:2015.

Jensen Hughes performed the test at the request of Cladding Safe Victoria.

Table 1 provides details of the test assembly, and Table 2 provides a summary of the test specimen. A summary of the results is provided in Table 3.

Table 1 Test assembly

Item	Detail	
Nominal non-loadbearing wall system	Height	8710 mm
	Thickness	Side protrusions – 274 mm
		Mid-section – 124 mm
Nominated width of main wall finished face	2631 mm	

Table 2 Test specimen

Item	Detail
Test specimen	<p>The façade consisted of a steel framing that was clad on the unexposed side with 13 mm fire rated plasterboard and 16 mm fire rated plasterboard on the exposed side. This assembly was designed to mimic the concrete panel (central recessed wall) and brick column (two side protrusions) construction of the building it was recreating.</p> <p>The exposed side also had aluminium louvres installed and 75 mm thick autoclaved aerated concrete (AAC) panels to simulate granite architectural features. The cavity behind the louvres were filled with ceramic fibre wool.</p> <p>The side protrusions at the second level of the façade were clad with folded aluminium composite panel (ACP), which was fixed in place through unequal angles installed full-height onto face of the protrusions.</p>

Table 3 Test results

Parameter	Results
t_s , start time	2 minutes 39 seconds after ignition of crib
Peak temperature/time at Level 2, 50 mm external	744 °C at 08 minutes 23 seconds after t_s
Peak temperature/time at Level 1, 50 mm external	986 °C at 14 minutes 16 seconds after t_s



Contents

1.	Introduction	5
2.	Test specimen	5
2.1	Schedule of components	5
2.2	Installation details	9
3.	Test procedure	10
4.	Test measurements and results	11
5.	Application of test results	11
5.1	Test limitations	11
5.2	Variations from the tested specimen	11
5.3	Uncertainty of measurements	11
Appendix A	Drawings of test assembly	12
Appendix B	Test observations	28
Appendix C	Test data	31
Appendix D	Photographs	39
Appendix E	Chemical analysis results	50

1. Introduction

This report documents the findings of the reaction to fire test for a non-loadbearing external wall system performed on 19 December 2024 in general accordance with BS 8414-2:2015.

Jensen Hughes performed the test at the request of the test sponsor listed in Table 4.

Table 4 Test sponsor details

Test sponsor	Address
Cladding Safe Victoria	717 Bourke Street Docklands VIC 3808 Australia

2. Test specimen

2.1 Schedule of components

Table 5 describes the test specimen and lists the schedule of components. These were provided by the test sponsor and surveyed by Jensen Hughes.

All measurements were done by Jensen Hughes – unless indicated otherwise.

Detailed drawings of the test specimen are provided in Appendix A.

Table 5 Schedule of components

Item	Description		
Cladding			
1.	Item name	Aluminium composite panel (ACP) panel	
	Product	██	
	Manufacturer/Supplier	██████	
	Note on Supply of Panel	On behalf of CSV, Jensen Hughes acquired the ACPs with 100 % polyethylene core. To the best of Jensen Hughes' knowledge this is a custom production which the supplier doesn't normally supply. The panels were provided on the basis that this was for research purposes and not any purpose other than fire testing.	
	Material	The material was nominated as panels consisting of two layers of aluminium sheets sandwiching a layer (core) with 100 % polyethylene (PE). Analysis conducted by the analytical centre of UNSW showed that the core consisted of polyethylene (PE) - found to be 96 % w/w - whilst the remainder of the material was found to be 3.3 % inert material. Refer to Sample #1 in Appendix E for more detailed results.	
	Colour	Skins	Front skin – Gloss white Back skin – Light grey
		Core	Black
	Size	Total panel thickness – 4.0 mm Skin thickness – 0.5 mm (both) Uncut: 4.0 m × 1.22 m Refer to Figure 1 for individual panel sizing details.	
	Batch	2023/12/05	
Areal density	5.6 kg/m ² (measured)		
2.	Item name	16 mm fire rated plasterboard	



Item	Description	
	Product name	[REDACTED]
	Manufacturer	[REDACTED]
	Size	1200 mm wide × 3600 mm long × 16 mm thick (uncut)
	Batch date	29/08/2024
3.	Item name	13 mm fire rated plasterboard
	Product name	[REDACTED]
	Manufacturer	[REDACTED]
	Size	1200 mm wide × 3600 mm long × 13 mm thick (uncut)
	Batch date	31/07/2024
4.	Item name	75 mm AAC panel
	Product name	[REDACTED]
	Manufacturer	[REDACTED]
	Size	600 mm wide × 2400 mm long × 75 mm thick (uncut)
	Batch number	1171461
5.	Item name	Aluminium louvre
	Product name	[REDACTED]
	Manufacturer	[REDACTED]
	Overall size	1044 mm long × 619 mm tall × 50 mm thick (uncut)
	Batch number	Unknown
Framing		
6.	Item name	Top track/base track
	Material	Steel
	Size	92 mm × 1500 mm × 40 mm, 1.15 mm B.M.T.
	Manufacturer	[REDACTED]
	Batch number	Unknown
7.	Item name	Steel stud
	Size	92 mm × 2100 or 2600 mm × 40 mm, 1.15 mm B.M.T.
	Manufacturer	[REDACTED]
	Batch number	20/11/24
	Installation	Studs at max. 600 mm. Also used as connector between the front and back steel frame.
8.	Item name	Steel nogging
	Size	92 mm × 580 mm × 40 mm, 0.75 mm B.M.T.
	Manufacturer	[REDACTED]
	Batch number	5/11/24
	Installation	Running horizontally at max. 1200 mm centres.
Flashing		
9.	Item name	Cladding angle
	Size	100 mm × 45 mm × 1.6 mm B.M.T.



Item	Description	
	Material	Galvanised steel
	Supplier	[REDACTED]
	Batch	5-OCT-2024
Insulation		
10.	Item name	25 mm ceramic fibre wool
	Size	1200 mm × 600 mm × 90 mm
	Density	128 kg/m ³ (nominated)
	Manufacturer	[REDACTED]
	Batch	T2440016134
Sealant/Adhesive		
11.	Item name	Glazing sealant
	Product name	[REDACTED]
	Manufacturer	[REDACTED]
	Batch	0002346687 2J4 A1007
	Density	1020 kg/m ³ (nominated)
Fixings		
12.	Item name	Framing screw
	Manufacturer	[REDACTED]
	Batch number	Unknown
	Description	#8g × 16 mm self-drilling fine thread button head screw
13.	Item name	False slab screw
	Manufacturer	[REDACTED]
	Batch number	Unknown
	Description	#14-10 × 65 type 17 hex head and washer screw
14.	Item name	Plasterboard screw
	Manufacturer	[REDACTED]
	Batch number	Unknown
	Description	#6 × 32 mm needle point fine thread plasterboard screw
15.	Item name	Angle screw
	Manufacturer	[REDACTED]
	Batch number	Unknown
	Description	12g × 35 mm hex head screw
16.	Item name	ACP screw
	Manufacturer	[REDACTED]
	Batch number	Unknown
	Description	#8g × 30 mm needle point button head screw
17.	Item name	AAC screw
	Manufacturer	[REDACTED]
	Batch number	Unknown

Item	Description	
	Description	14-10 × 125 mm type 17 bugle head, internal hex drive screw
Steel substrate		
18.	Item name	Steel substrate
	Size	The steel substrate was 9300 mm high × 3245 mm wide for the main wall and 9300 mm high × 2000 mm wide for the wing wall
	Description	The substrate consisted of structural steel sections and square hollow sections (SHS).
19.	Item name	False slab
	Description	3050 mm leg × 1545 mm leg × 150 mm square hollow section
Installation method		
EW	Overall size	8710 mm high × 2671 mm wide × 313 mm overall depth
	Installation	<ul style="list-style-type: none"> • The steel framing (item 5 to 7) was constructed as detailed in Figure 12, Figure 13, Figure 14, Figure 16, Figure 18 and Figure 19 and fixed in place between the false slabs (item 19) using plasterboard screws (item 14). • The 16 mm plasterboard (item 2) was then fixed to the steel framing on the front and sides, and the 13 mm plasterboard (item 3) was fixed to the back of the steel framing. Two apertures were then cut out on the front side and internally lined with single layer of 16 mm plasterboard to make an internal 1000 mm wide × 575 mm high opening. The back plasterboard was not cut. • Two 75 mm AAC panels (item 4) were fixed below the apertures using AAC screws (item 17). Refer to Figure 7 and Figure 8 for panel sizing and fixing locations. • The cladding angles (item 9) were then fixed in place using screws (item 15) at 300 mm centres. The ACP (item 1) was then fixed to the angles using screws (item 16) at 50 mm from the ends and one at mid height of the panel segments. • Two layers of ceramic fibre wool (item 10) was stacked to make it 50 mm thick, which was then friction fitted into the two apertures, as illustrated in Figure 7 and Figure 8. Three holes were cored through the ceramic fibre wool, as shown in Figure 6. • The apertures were then covered using louvres (item 5) which was fixed in place using screws (item 16). • Glazing sealant (item 11) was used to create an outline on the first and second floor, as shown in green line in Figure 22. • Refer to Appendix A for further construction details.

2.2 Installation details

Table 6 lists the installation details for the test specimen.

Table 6 Installation details

Item	Detail
Start date for construction of the test specimen	13 December 2024
Completion date for construction of the test specimen	19 December 2024
External wall system constructed by	Representatives of Jensen Hughes
Symmetry	<p>Asymmetrical because:</p> <ul style="list-style-type: none"> • Only the unexposed side was clad with 13 mm fire rated plasterboard, while the exposed side was clad 16 mm fire rated plasterboard. • The ACP was only clad on the second level of the exposed face of the façade. • The AAC panels and louvers were only installed on the exposed side. <p>It was confirmed that the system was exposed from the side that would normally face the outside of the building.</p>

3. Test procedure

Table 7 details the test procedure for this reaction to fire test.

Table 7 Test procedure

Item	Detail	
Statement of compliance	The test was performed in general accordance with the requirements of BS 8414-2:2015+A1:2017 for a non-loadbearing external cladding system fixed to and supported by a structural steel frame.	
Variations	<ul style="list-style-type: none"> • Only the main wall was clad with the system to be tested, while the wing wall was not. • Only the main wall thermocouples were used to record the temperatures during the test. • Only the second level of the façade was clad with ACP, while the first level was not clad. • The ignition source of the test was constructed from Pinus Radiata instead of Pinus Silvestris. This variation is not considered to have affected the outcome of the test. 	
Environmental conditions at the start of the test	Start of the test	33 °C
	Wind speed	1.1 m/s
Ignition source	Crib material	Softwood (radiata pine)
	Moisture content	11 %
	Density	440 kg/m ³
Sampling / specimen selection	<p>The laboratory was not involved in sampling or selecting the test specimen for the reaction to fire test.</p> <p>The results obtained during the test only apply to the test samples as received and tested by Jensen Hughes.</p>	
Test duration	60 minutes	
Instrumentation and equipment	<p>The instrumentation was provided in general accordance with BS 8414-2:2015 as follows:</p> <ul style="list-style-type: none"> • Exposed and cavity temperatures were measured by mineral insulated metal sheathed (MIMS) Type K thermocouples with an overall diameter of 1.5 mm with the measuring junction insulated from the sheath. • Exposed temperatures were measured by 100 mm × 100 mm × 0.7 mm plate thermometers with mineral insulated metal sheathed (MIMS) Type K thermocouples with an overall diameter of 1.5 mm with the measuring junction electrically insulated from the sheath. The thermocouple hot junction was fixed to the geometric centre of the plate by a small steel strip made from the same material-as the plate. The plate thermometers included 97 mm × 97 mm × 10 mm inorganic insulation pads. Before the first use of the plate thermometers, they were aged by being exposed to heat in a fire-resistance test furnace for 90 min under the standard temperature/ time curve. • The thermocouple positions are shown in Figure 24 in Appendix C. • The wind speed was measured by an anemometer at Level 2, 1000 mm forward from the centre line of the combustion chamber. • Timber crib moisture was measured by a pin-type moisture meter. 	

4. Test measurements and results

Table 9 shows the peak temperatures the test specimen achieved as listed in BS 8414-2:2015+A1:2017.

The temperature measurements for the test specimen are included in Appendix C.

Table 10 in Appendix B includes observations of any significant behaviour of the specimen and details the occurrence of the various performance criteria specified in BS 8414-2:2015+A1:2017.

Photographs of the specimen are included in Appendix D.

Table 8 Test results

Parameter	Results
t_s , start time	2 minutes 39 seconds after ignition of crib
Peak temperature/time at Level 2, 50 mm external	744 °C at 08 minutes 23 seconds after t_s
Peak temperature/time at Level 1, 50 mm external	986 °C at 14 minutes 16 seconds after t_s

5. Application of test results

5.1 Test limitations

The results of these fire tests may be used to directly assess fire hazard, but it should be recognised that a single test method will not provide a full assessment of fire hazard under all fire conditions.

These results only relate to the behaviour of the specimen of the element of construction under the particular conditions of the test. They are not intended to be the sole criteria for assessing the potential fire performance of the element in use, and they do not necessarily reflect the actual behaviour in fires.

5.2 Variations from the tested specimen

This report details methods of construction, the test conditions and the results obtained when the specific element of construction described here was tested following the procedure outlined in BS 8414-2:2015+A1:2017.

Any significant variation with respect to size, construction details, loads, stresses, edge or end conditions, other than that allowed under the field of direct application in the relevant test method, is not covered by this report.

5.3 Uncertainty of measurements

Because of the nature of reaction to fire testing and the consequent difficulty in quantifying the uncertainty of measurements obtained from a reaction to fire test, it is not possible to provide a stated degree of accuracy of result.



Appendix A Drawings of test assembly

The drawings of the test assembly in Figure 1 to Figure 20 were provided by the test sponsor and marked up by Jensen Hughes. The leaders in the drawings represent the items listed in section 2.1. All measurements – unless indicated – are in millimetres.

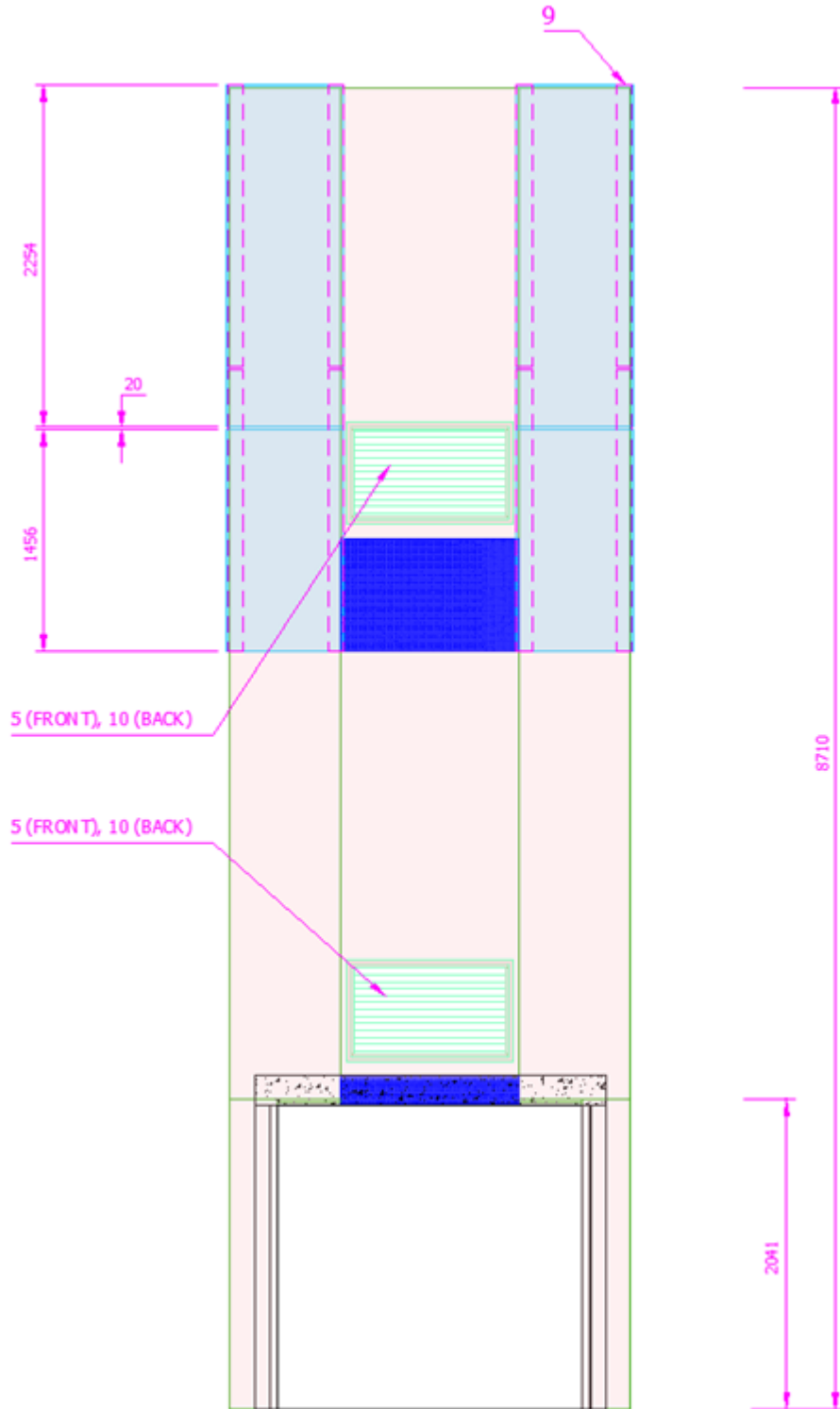

Figure 1 Overall view – exposed face of the specimen

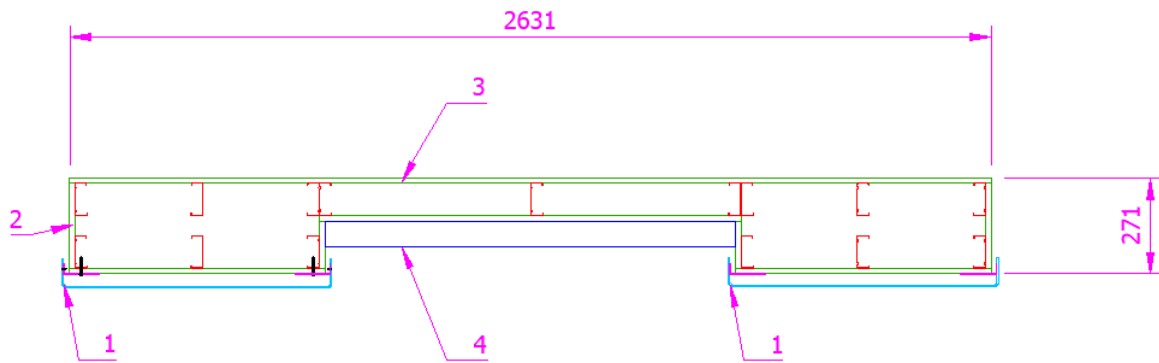

Figure 2 Top view of the specimen

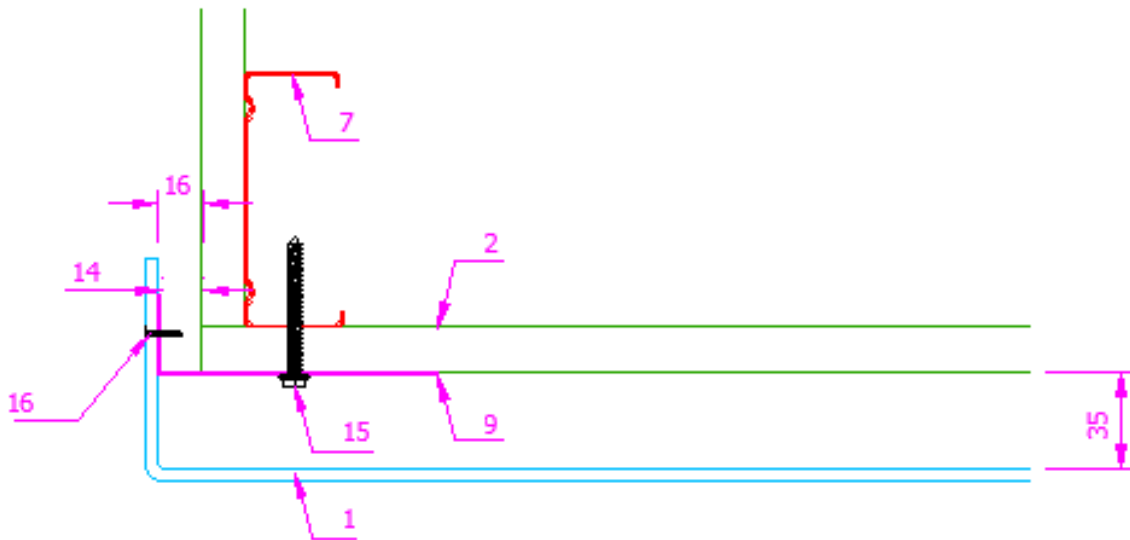

Figure 3 ACP fixing detail

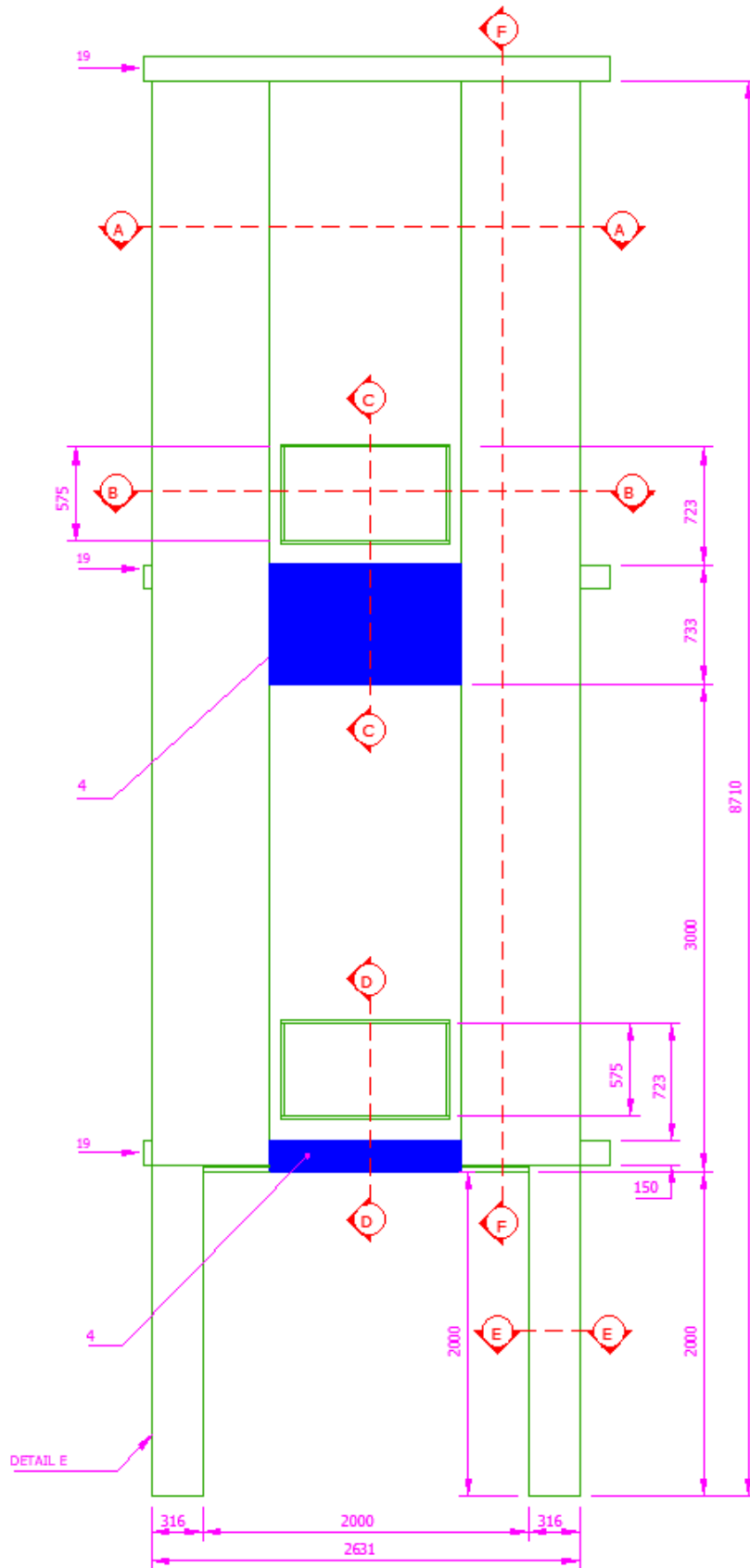

Figure 4 Plasterboard section – plasterboard wall detail

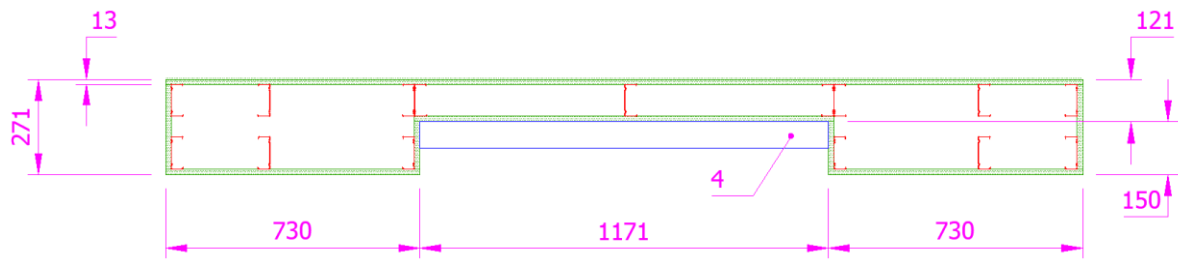

Figure 5 Cross section A-A

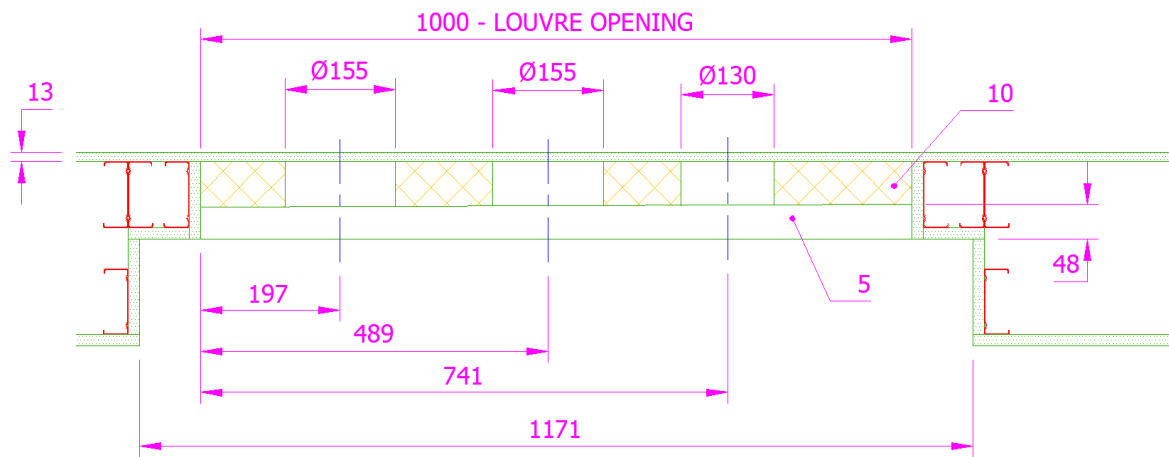

Figure 6 Cross section B-B

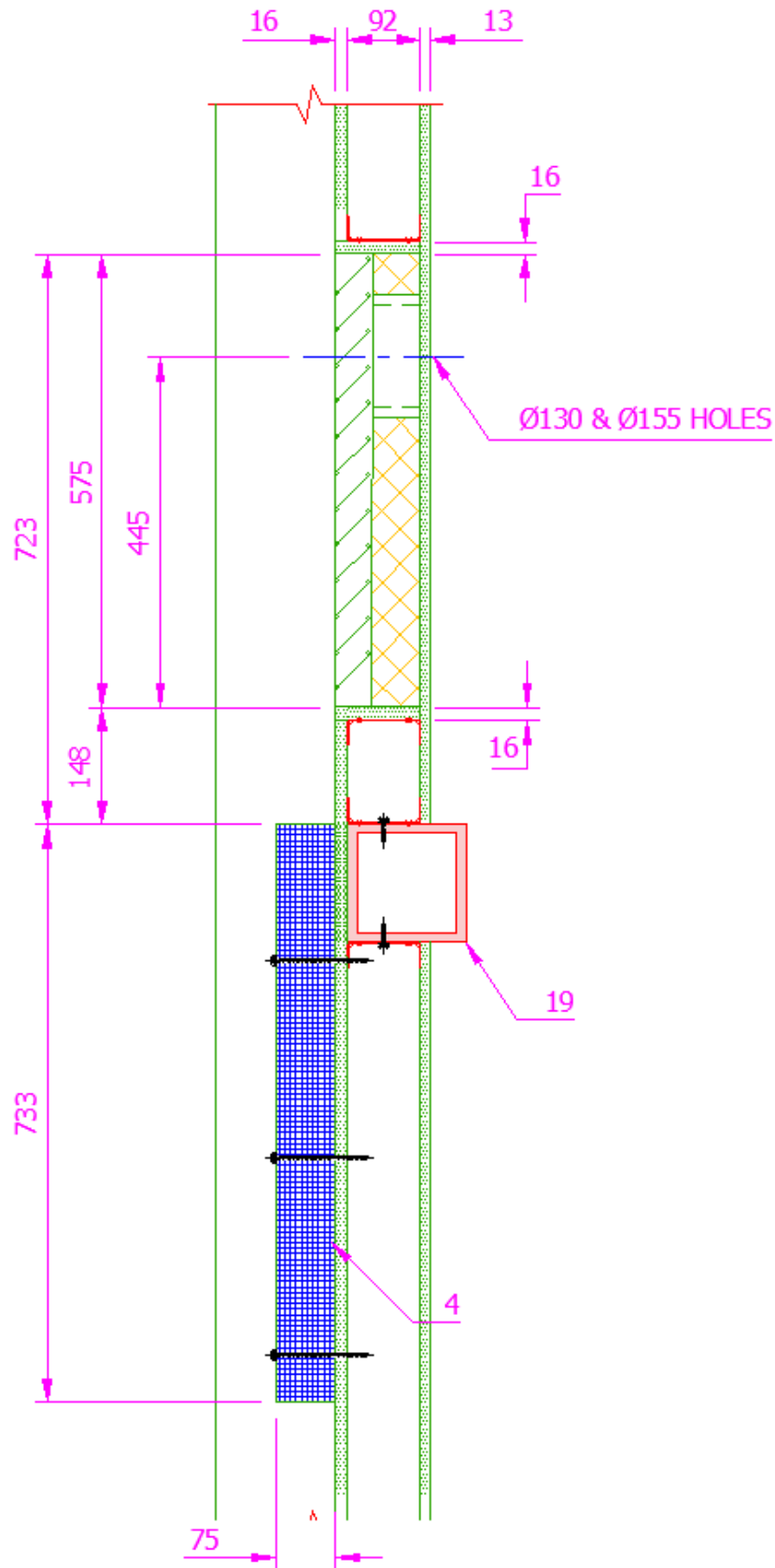

Figure 7 Cross section C-C

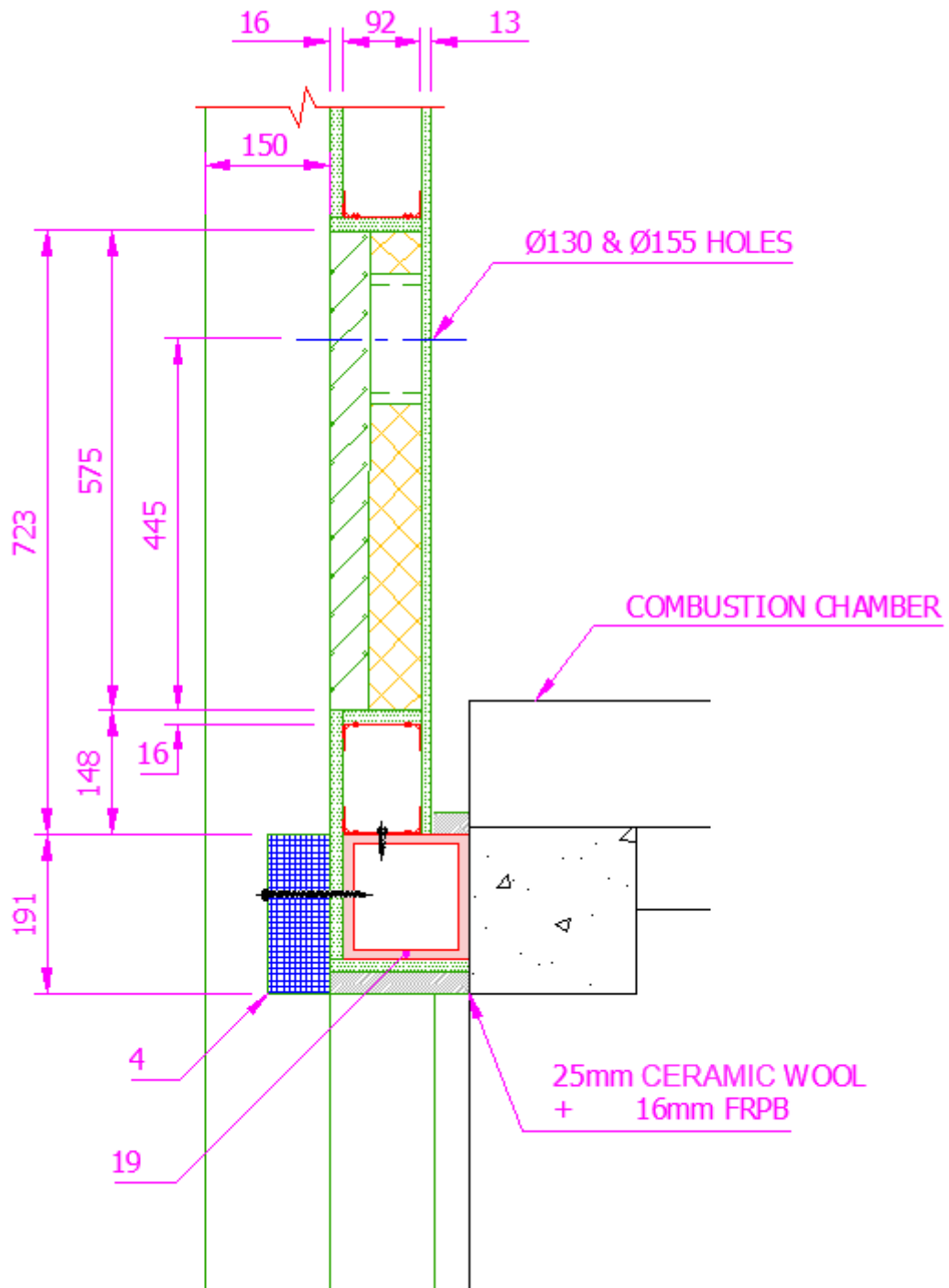

Figure 8 Cross section D-D

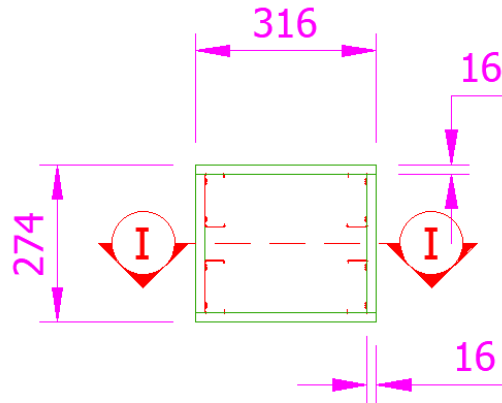

Figure 9 Cross section E-E

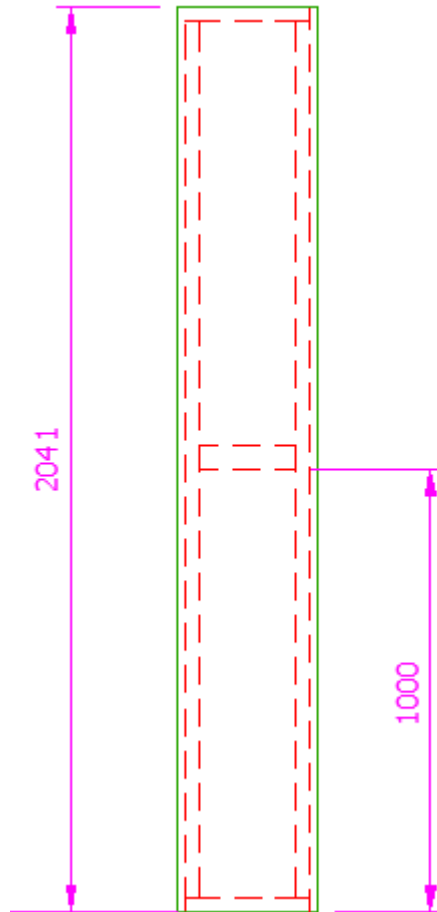

Figure 10 Cross section I-I

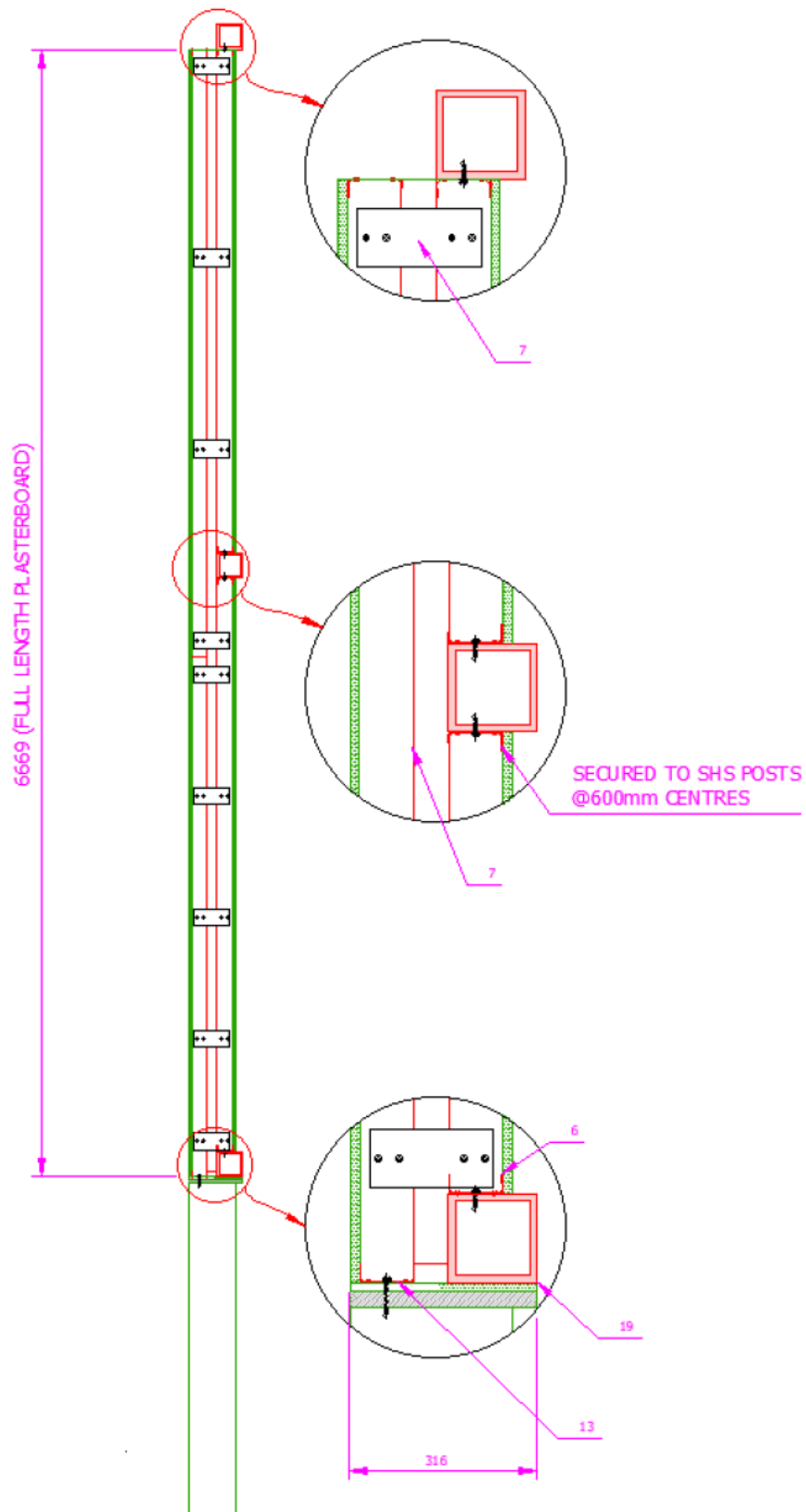

Figure 11 Cross section F-F

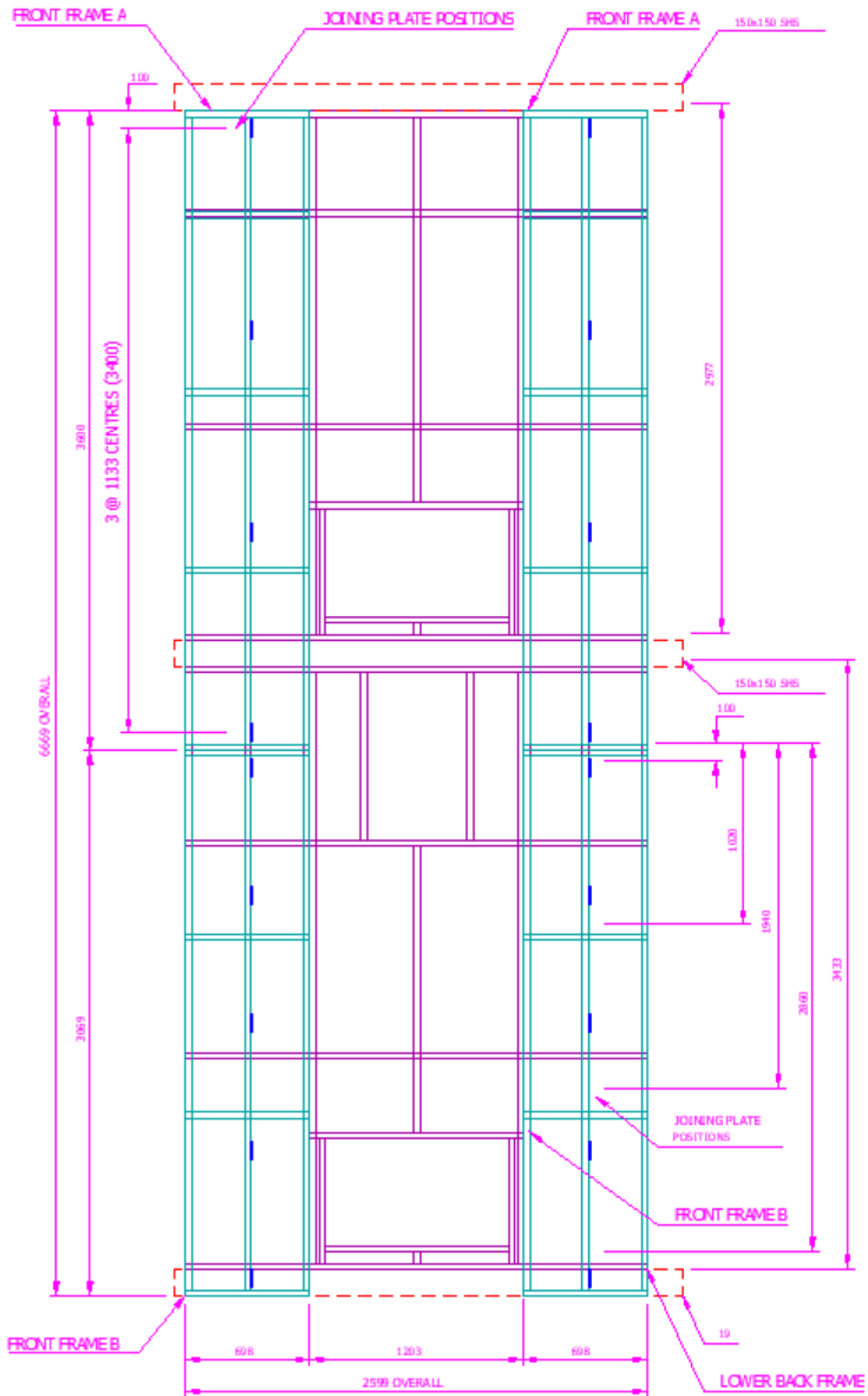

Figure 12 Front view – first and second level steel framing exposed view

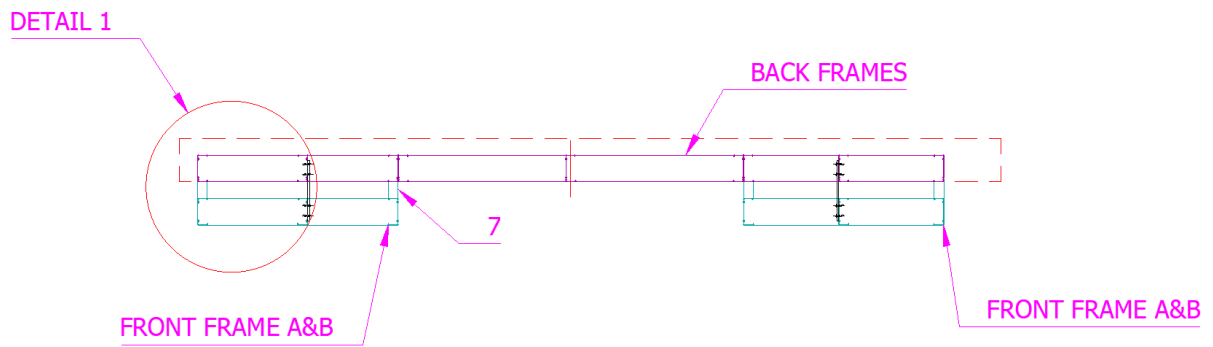

Figure 13 Top view – steel framing joint detail

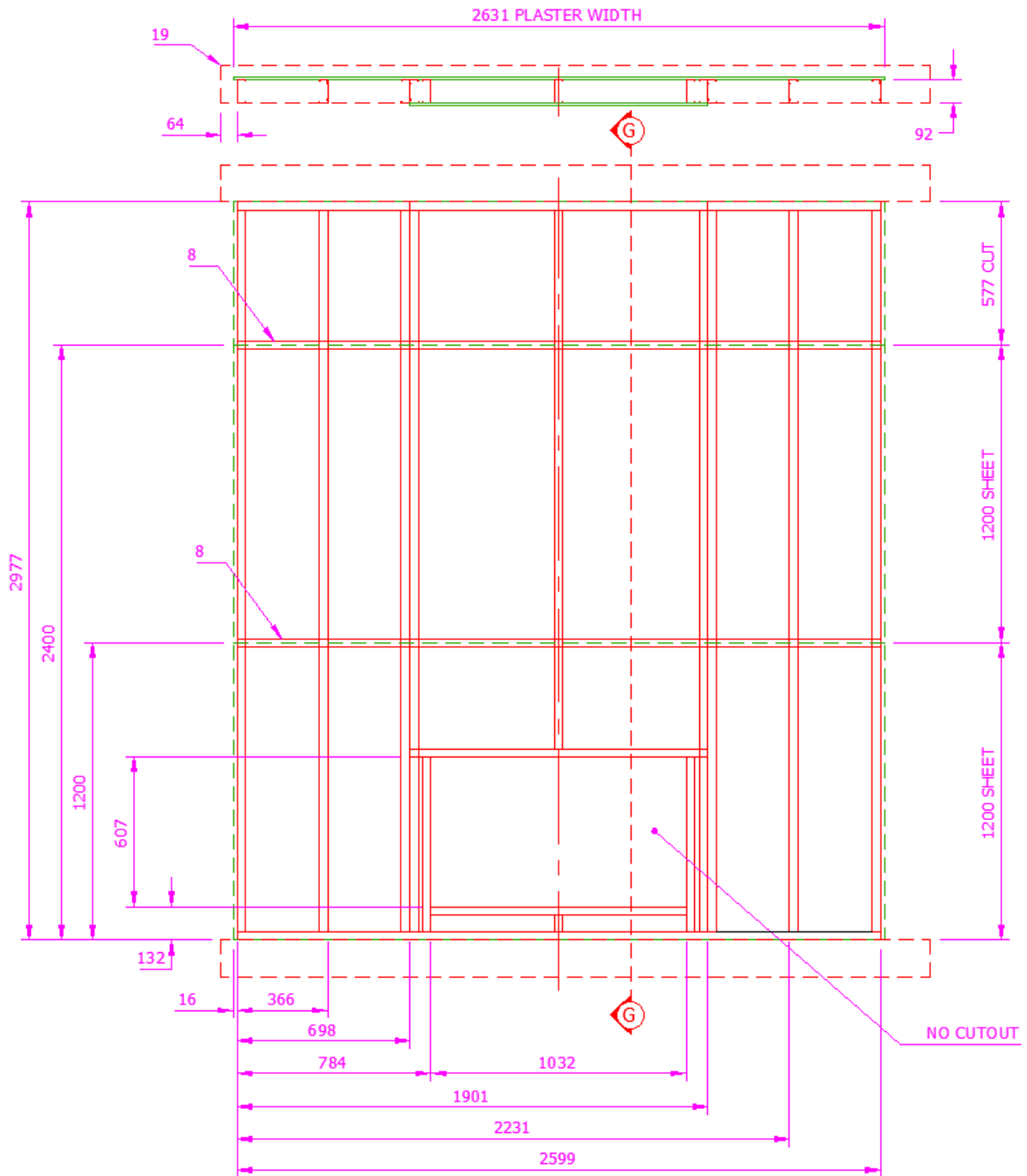

Figure 14 Front view – upper steel framing and plasterboard layout detail

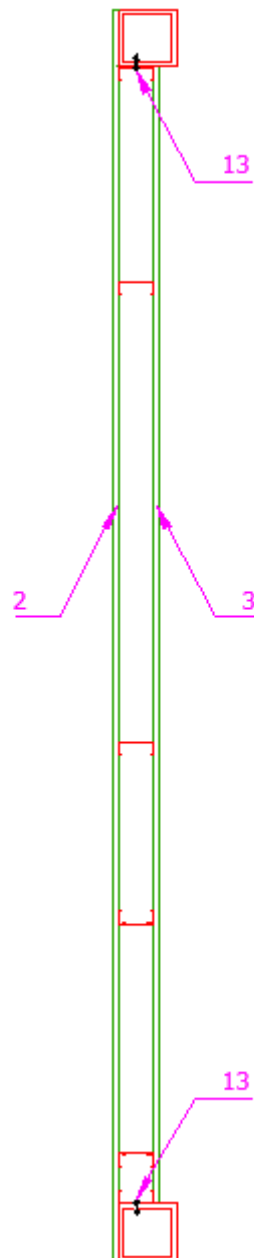

Figure 15 Cross section G-G – steel frame to false slab fixing detail

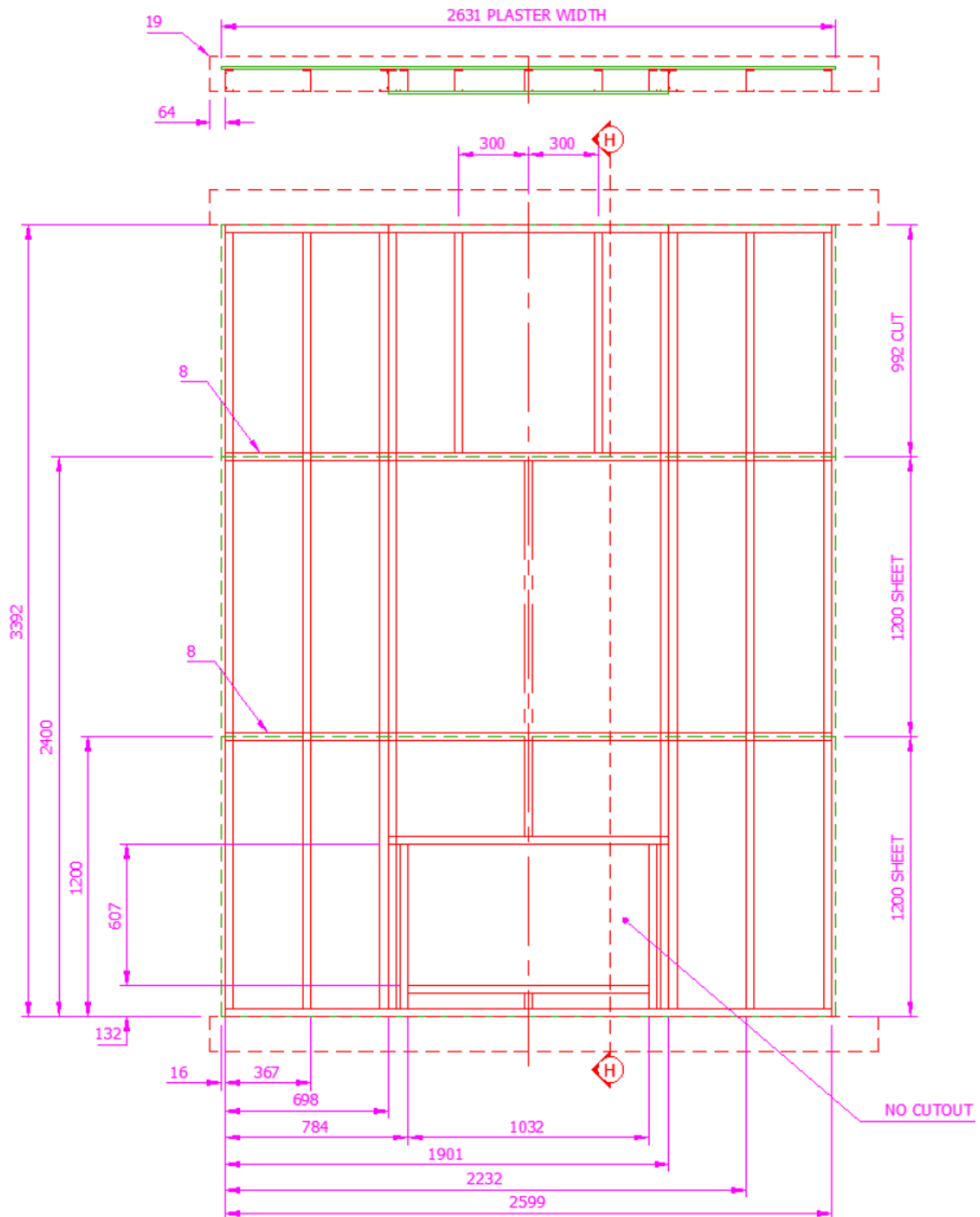

Figure 16 Front view – lower steel framing and plasterboard layout detail

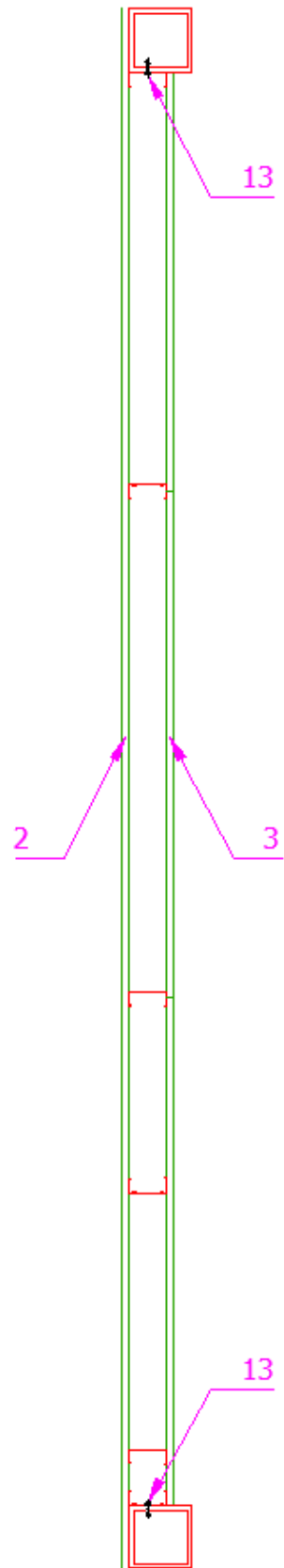

Figure 17 Cross section H-H

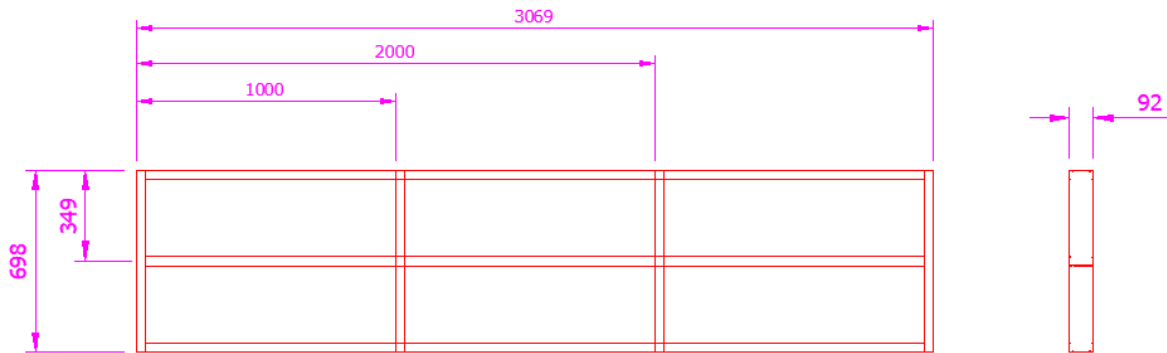

Figure 18 Steel framing details - front frame B

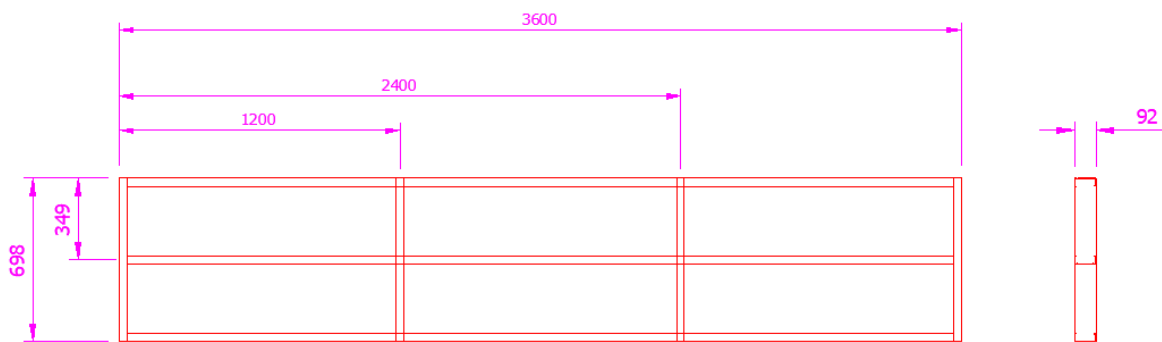

Figure 19 Steel framing details - front frame A

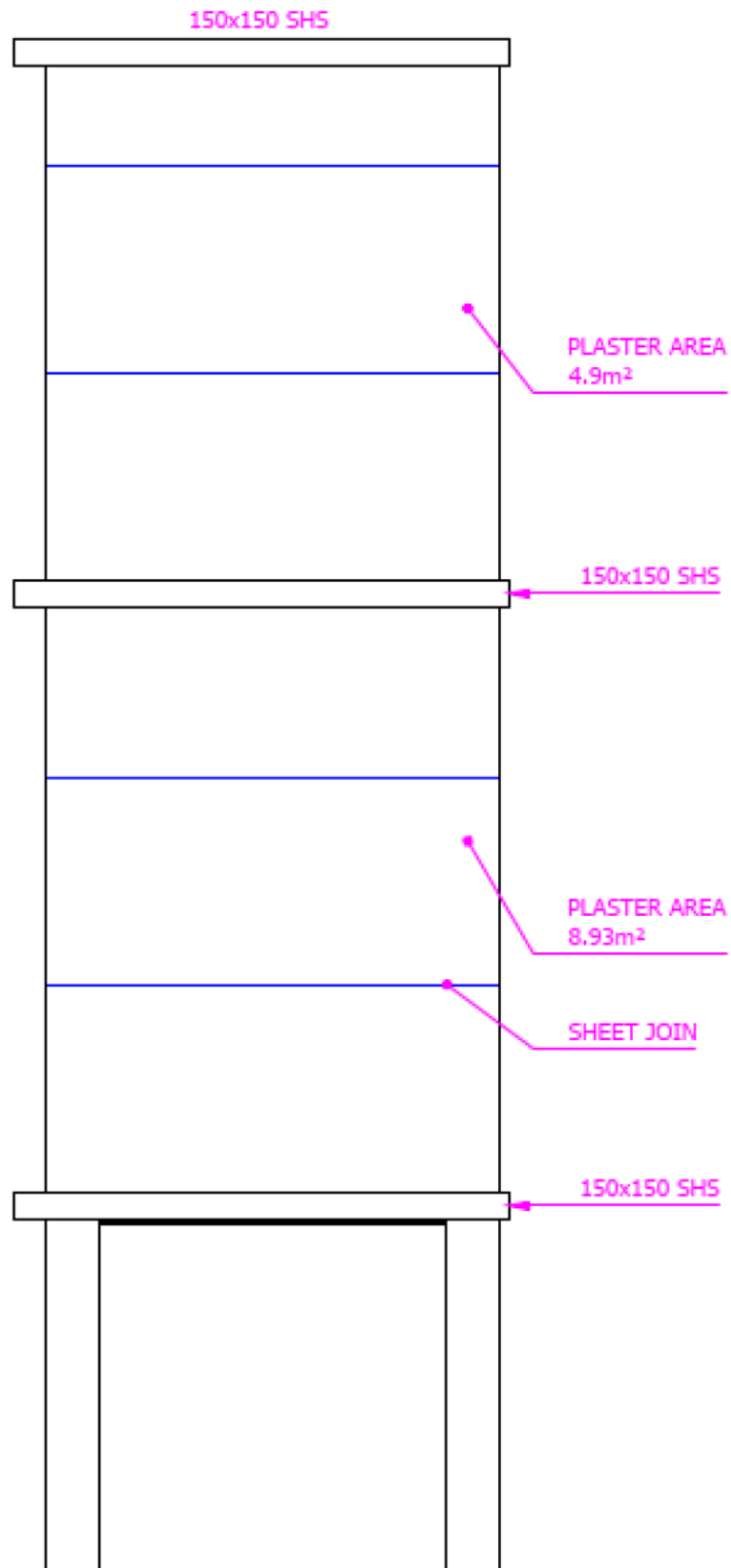

Figure 20 Overall view – unexposed side plasterboard layout

Appendix B Test observations

5.4 Visual observation

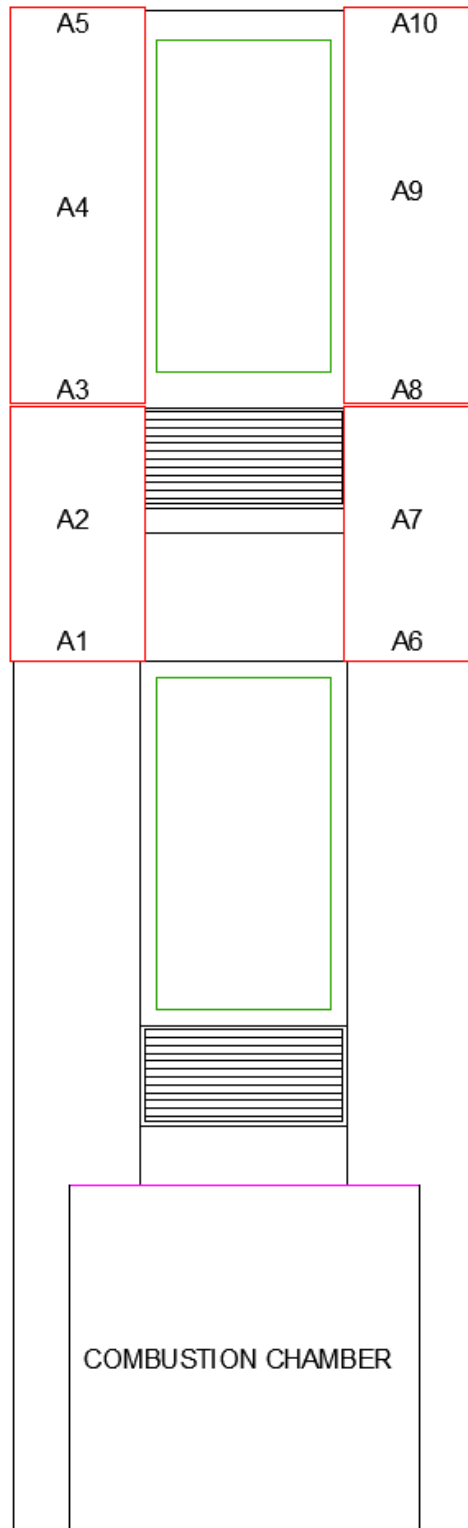

Figure 21 Observation designation

Table 9 shows the observations of any significant behaviour of the specimen during the test.

Table 9 Test observations

Time		Observation
Min	Sec	
0	00	The reaction to fire test was started.
1	24	Flames started to escape from the combustion chamber.
3	01	The first-floor louvres started to deform.
3	17	The plasterboard surrounding the first floor louvre started to discolour.
3	42	Intermittent flaming of the first floor perimeter seal.
4	15	The flames had reached the level 1 thermocouple trees.
4	35	The area around A1 started to deform.
5	10	The plasterboard above the louvre had discoloured most of the way up.
5	17	The area around A6 started to deform.
5	21	The first floor louvres had melted and dripped on to the ground.
6	16	The lower left corner of A6 started to flame intermittently.
6	48	The second floor louvre started to deform.
8	05	The flaming at A6 had become consistent.
8	57	Flaming of the fallen debris was observed, which lasted for more than 20 seconds.
9	22	The second floor AAC panel had discoloured on the right side.
9	55	A8 was flaming independently.
9	57	Some cracking sounds were heard from the specimen.
11	16	The flaming from A8 had spread upwards, extending past the top of the façade.
11	19	A puddle of flaming debris was observed on the ground below the façade.
12	00	Intermittent flaming of the top of the first floor perimeter seal.
13	40	The flaming at A6 and A8 had started to die off.
14	06	The bottom right corner of A1 had started to flame intermittently.
14	30	Most of the flaming debris on the floor had extinguished, leaving some remnants.
16	30	The debris from A1 falling on the floor was flaming consistently.
17	26	A3 was flaming independently.
21	10	The flames from A3 had spread upwards, extending past the top of the façade.
25	00	The ACP skin of A3 started to delaminate.
30	00	The crib was extinguished.
60	00	The test was ended.

5.5 Post-test observations

External wall system

The damaged area of the cladding system is described as follows.

Approximately 0.9 m² of the ACP had the core fully consumed and both ACP skins melting off.

Approximately 0.5 m² of the ACP had the core fully consumed and flame damaged skin.

Approximately 1.7 m² of the ACP had the core partially consumed and the skin delaminated.

The first floor louvre had fully melted off, while the second floor louvre had deformed during the test.

The glazing perimeter sealant for the first floor was fully consumed, while the sealant for the second floor was partially consumed.

Approximately 9.2 m² of the plasterboard and AAC face had flame damage.

See Figure 44 and Figure 45 for more details

The approximate mass of collected debris that fell in front of the specimen was 4.7 kg.

Approximate total mass of debris below 100 g was 1.06 kg.

Approximate total mass of debris and number of fragments between 100 g and 200 g was 0.42 kg and 3.

Approximate total mass of debris and number of fragments between 300 g and 400 g was 0.33 kg and 1.

Approximate total mass of debris and number of fragments between 400 g and 500 g was 0.46 kg and 1.

The individual mass of each fragment with a mass greater than 500 g are listed in Table 10 below:

Table 10 Fragments with a mass greater than 500 g

No	Mass (kg)
1	0.55
2	1.17
3	0.71

Appendix C Test data

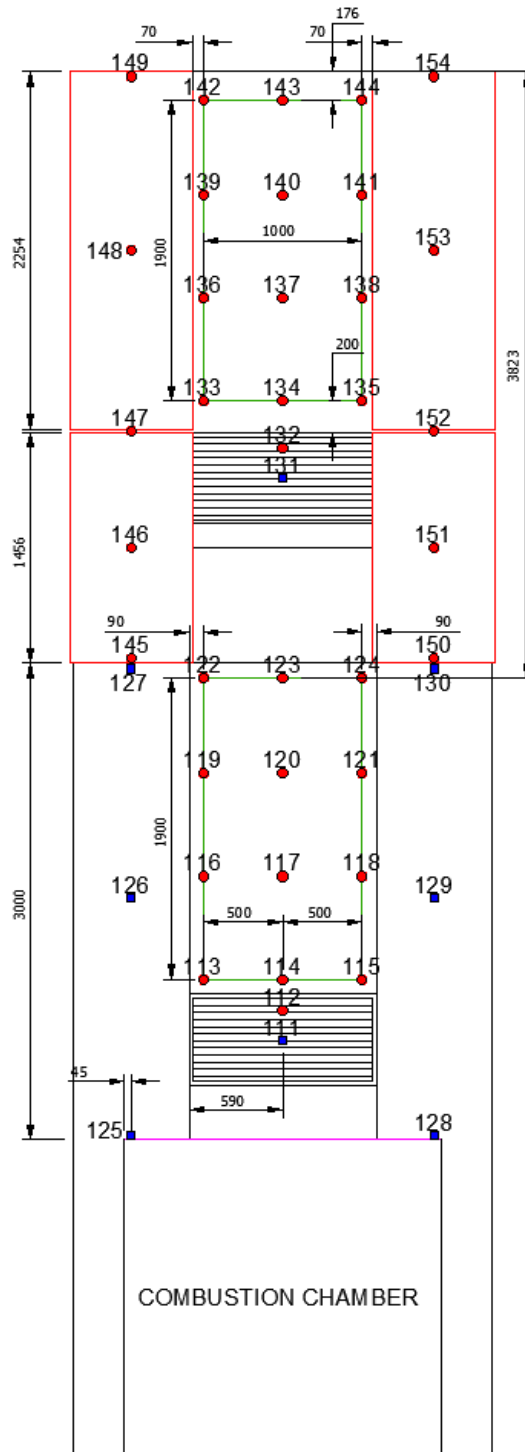

Note:

- Red dots show MIMS thermocouple locations.
- Blue squares show plate thermometer locations.

Figure 22 Thermocouple locations – exposed face

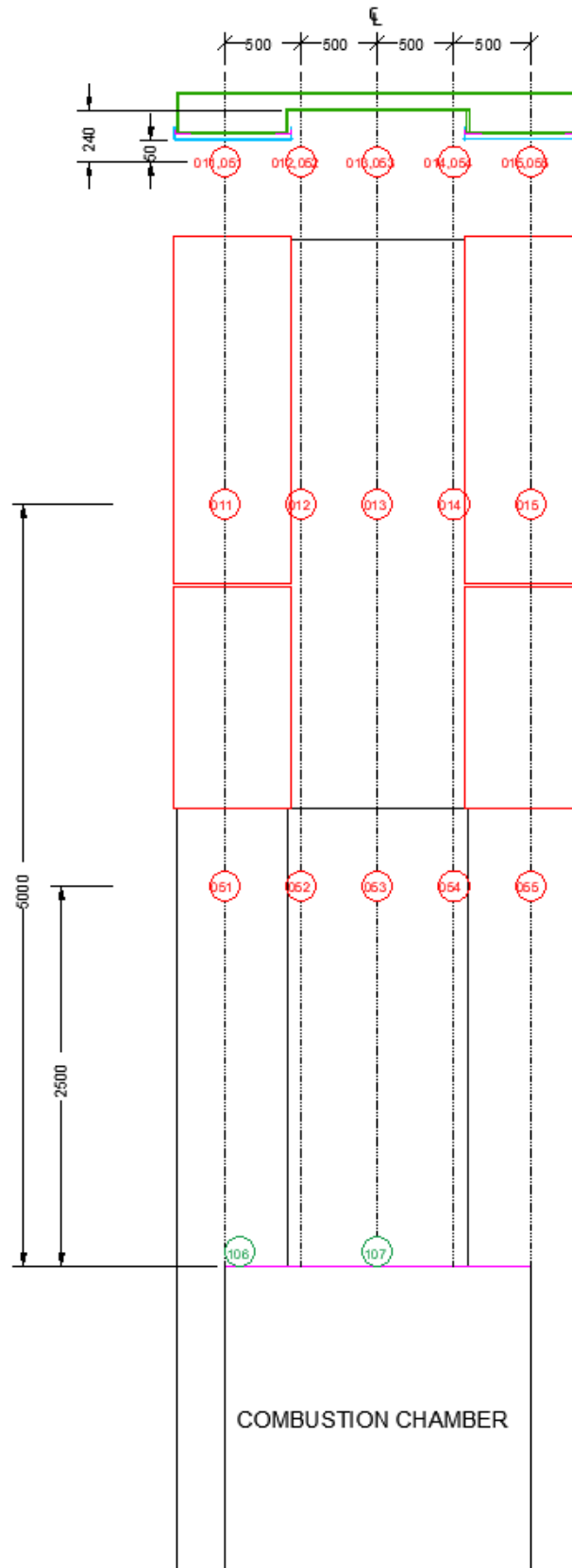

Figure 23 Thermocouple locations – BS8414-2

C.1 Specimen temperatures

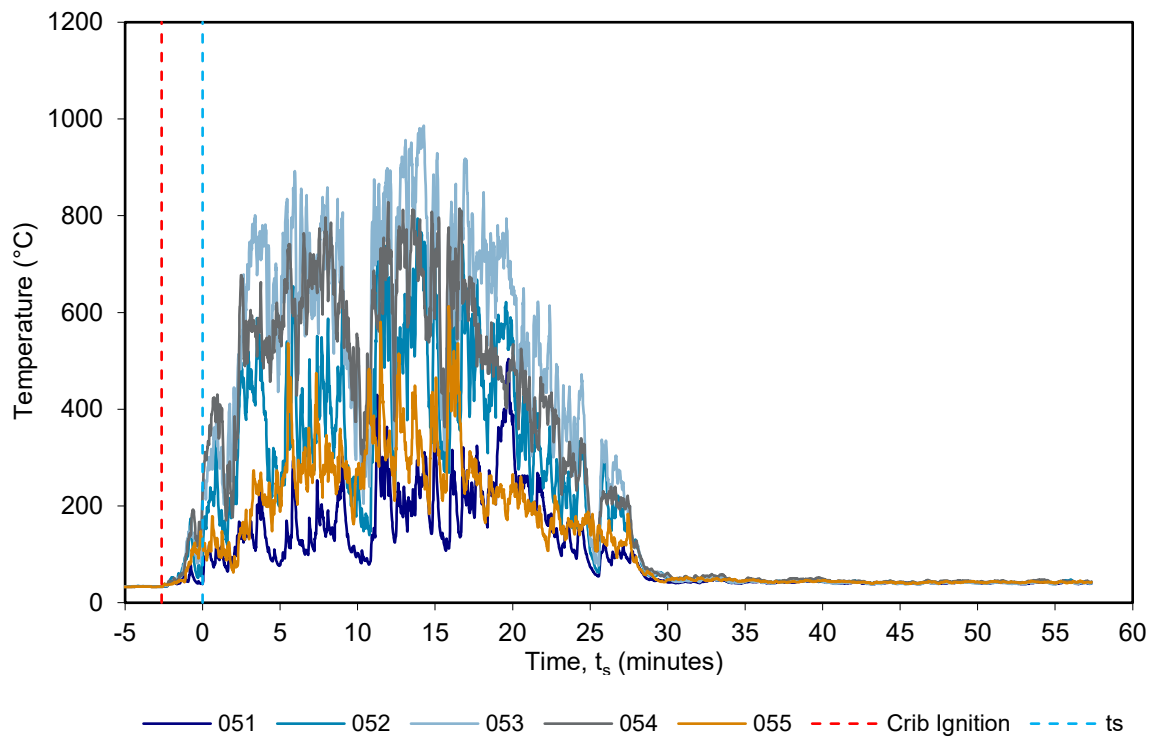

Figure 24 Level 1, external – temperature vs time

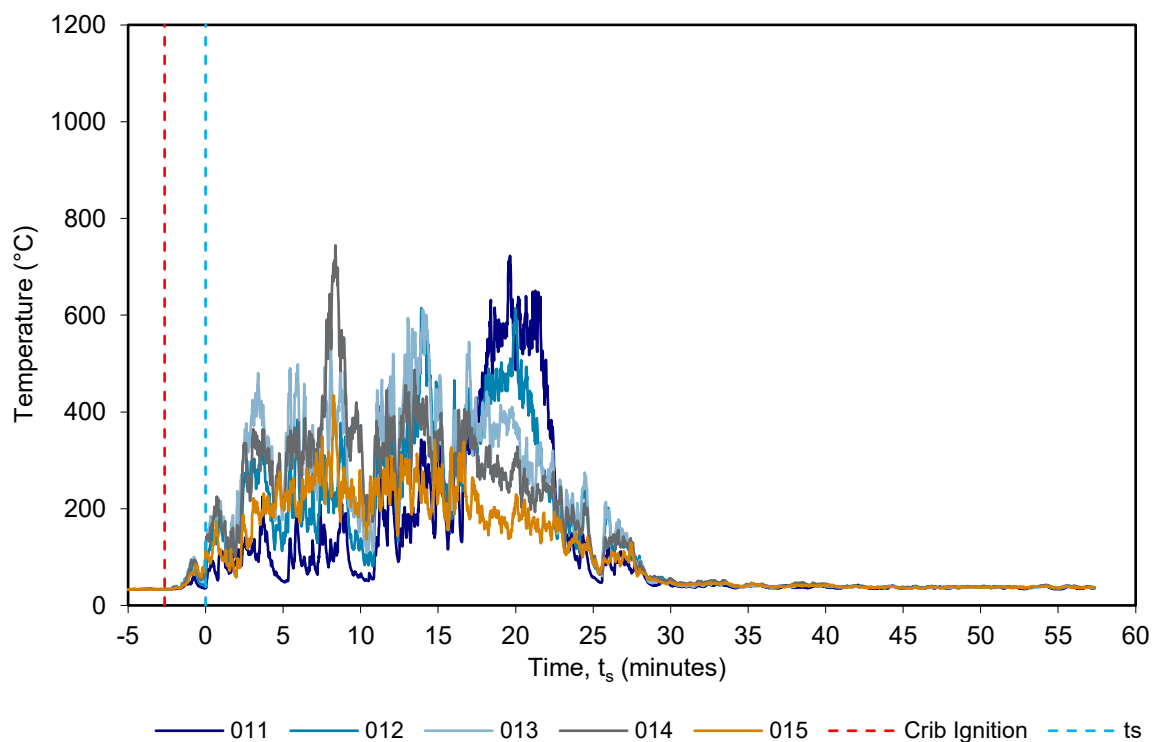

Figure 25 Level 2, external – temperature vs time

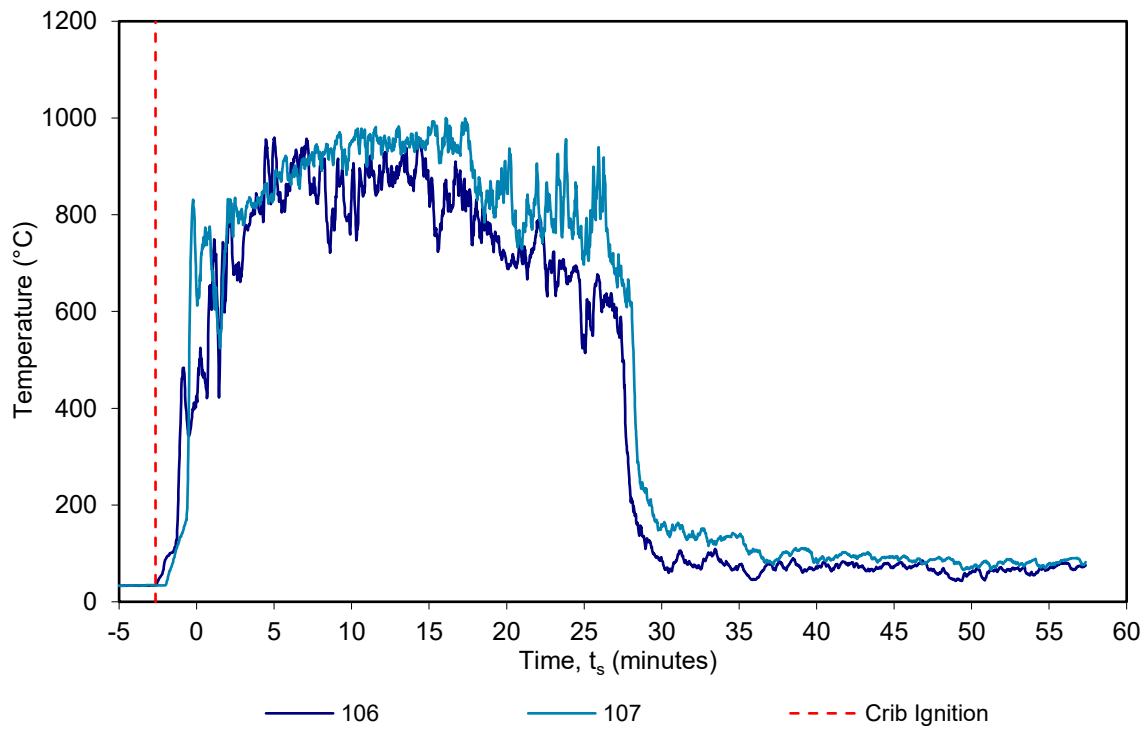

Figure 26 Combustion chamber, lintel – temperature vs time

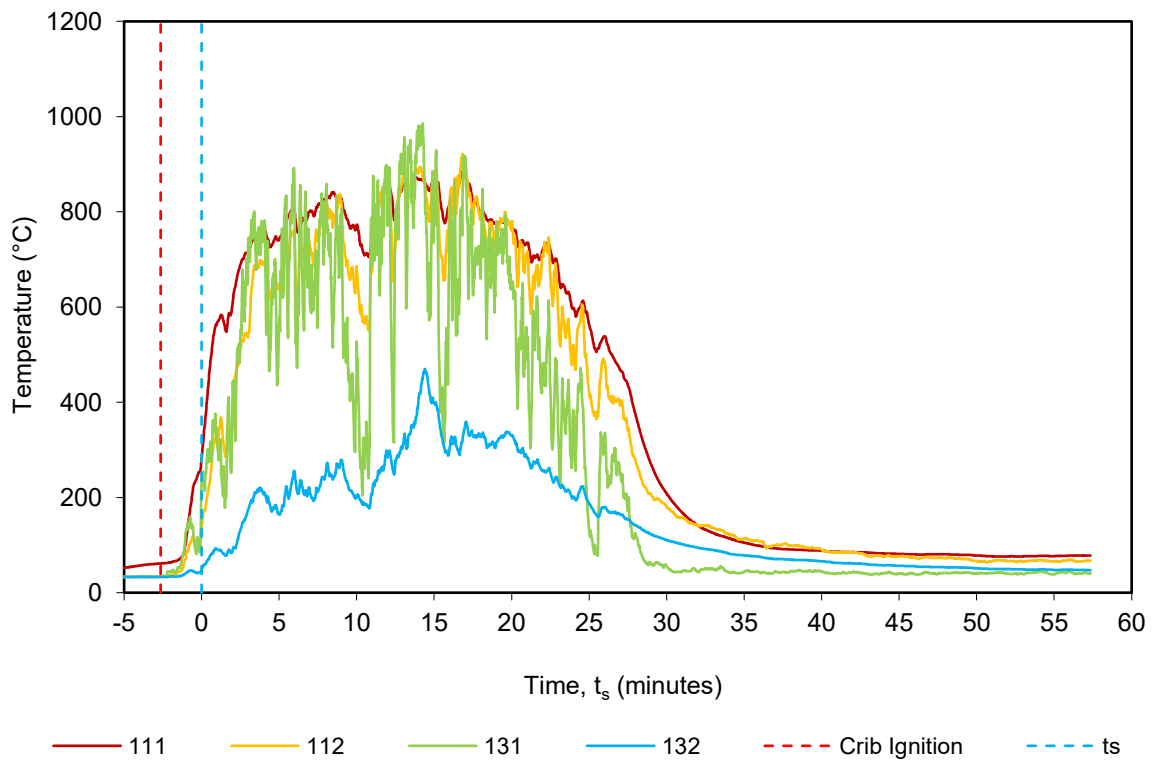

Figure 27 Louvre, plate and cavity thermocouples – temperature vs time

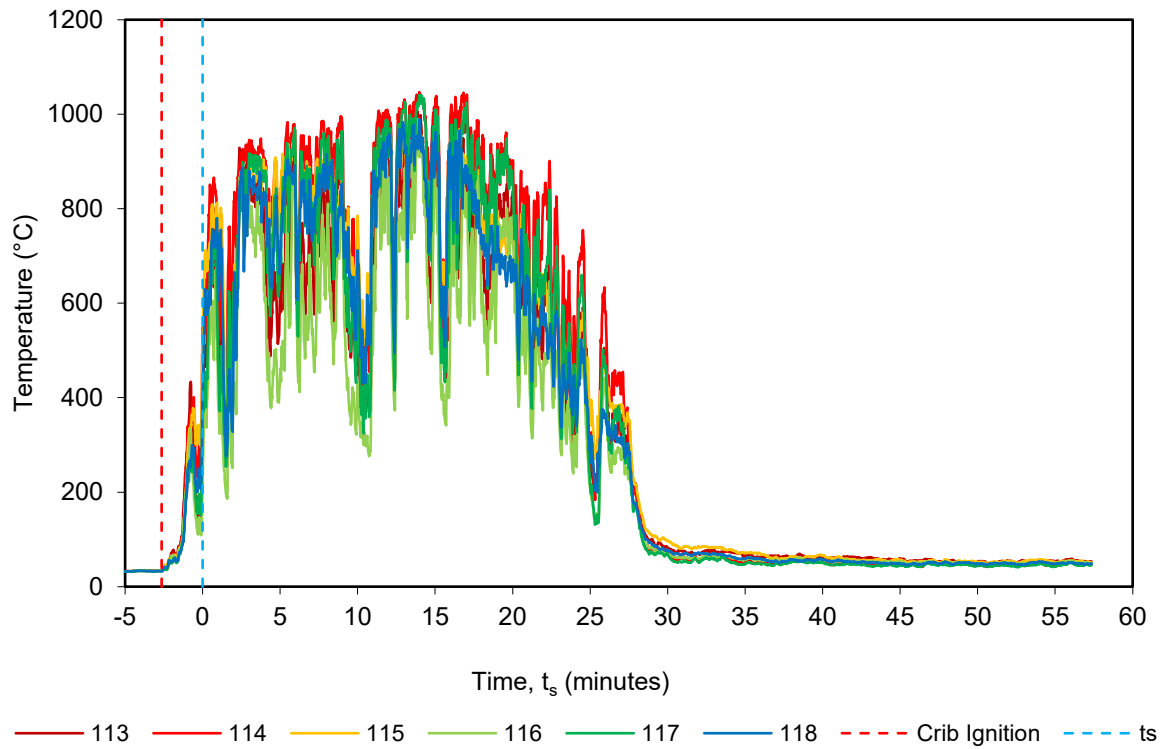

Figure 28 Bottom glazing outline thermocouples – temperature vs time

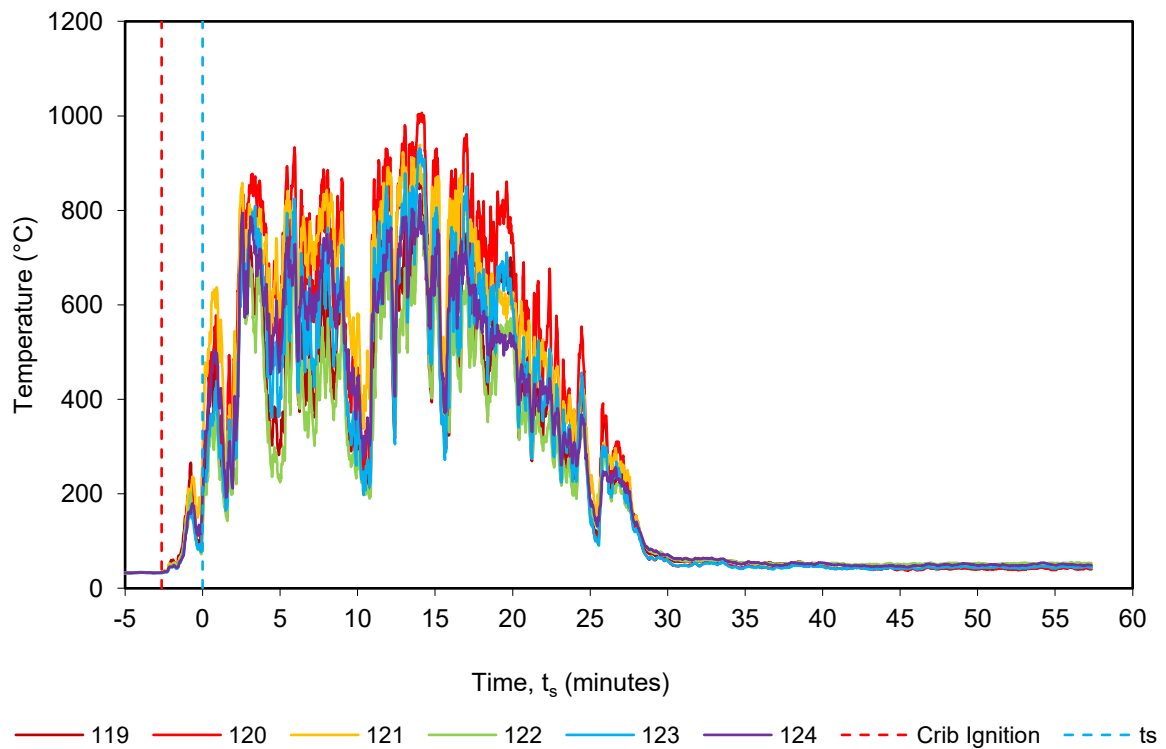

Figure 29 Bottom glazing outline thermocouples – temperature vs time

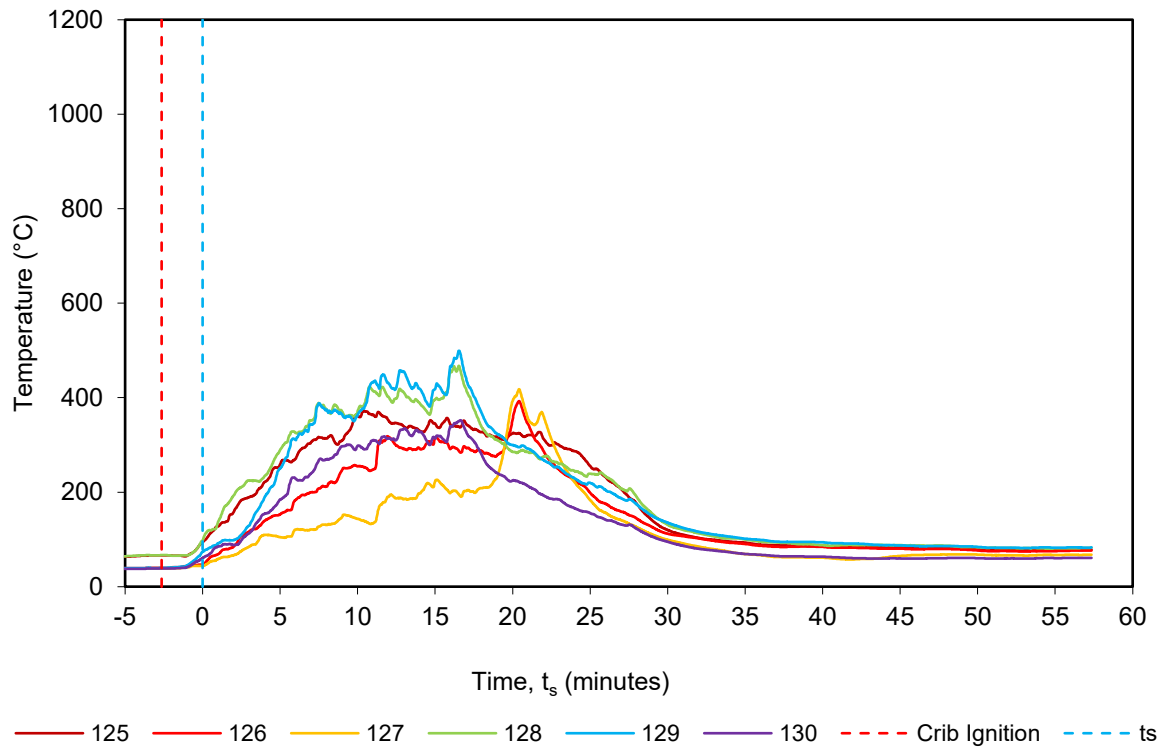

Figure 30 Exposed plasterboard face, plate thermometers – temperature vs time

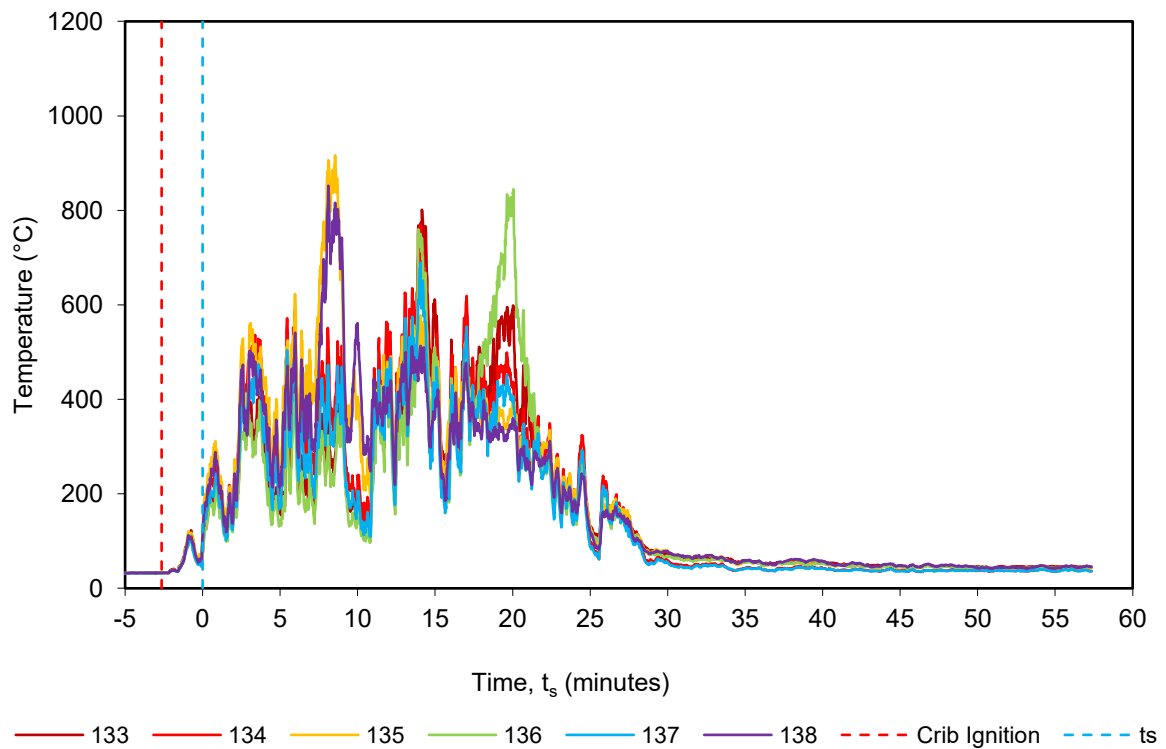

Figure 31 Top glazing thermocouples – temperature vs time

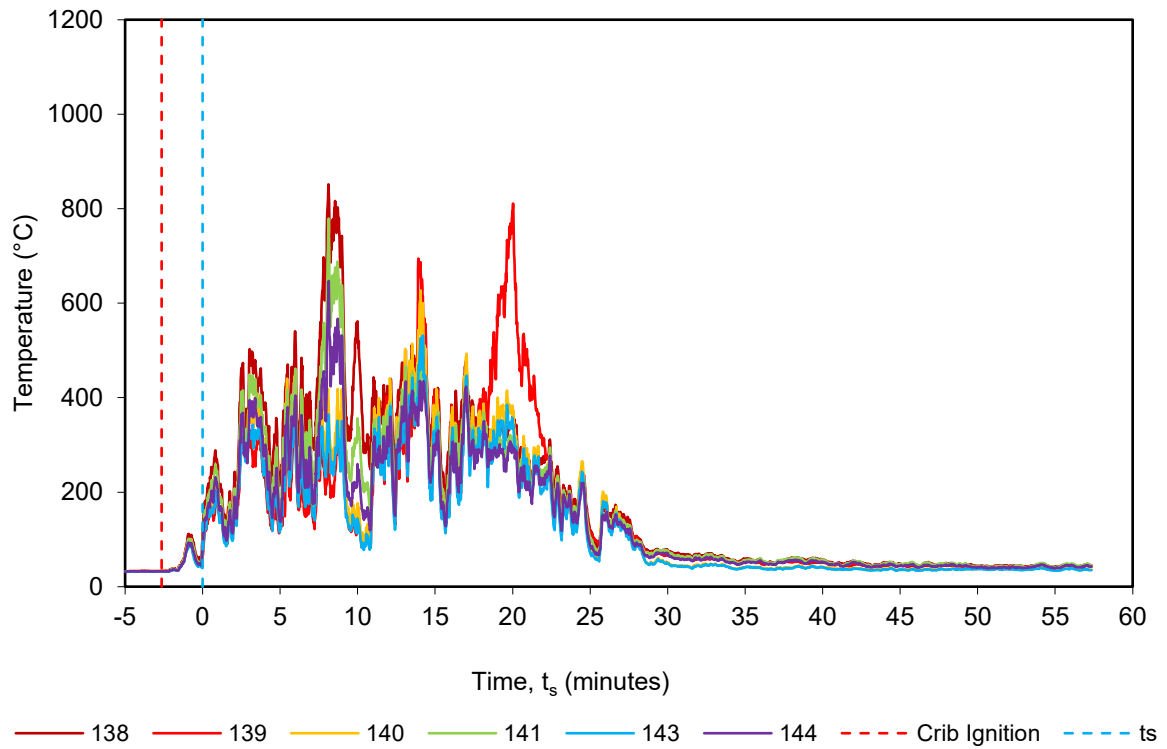

Figure 32 Top glazing thermocouples – temperature vs time

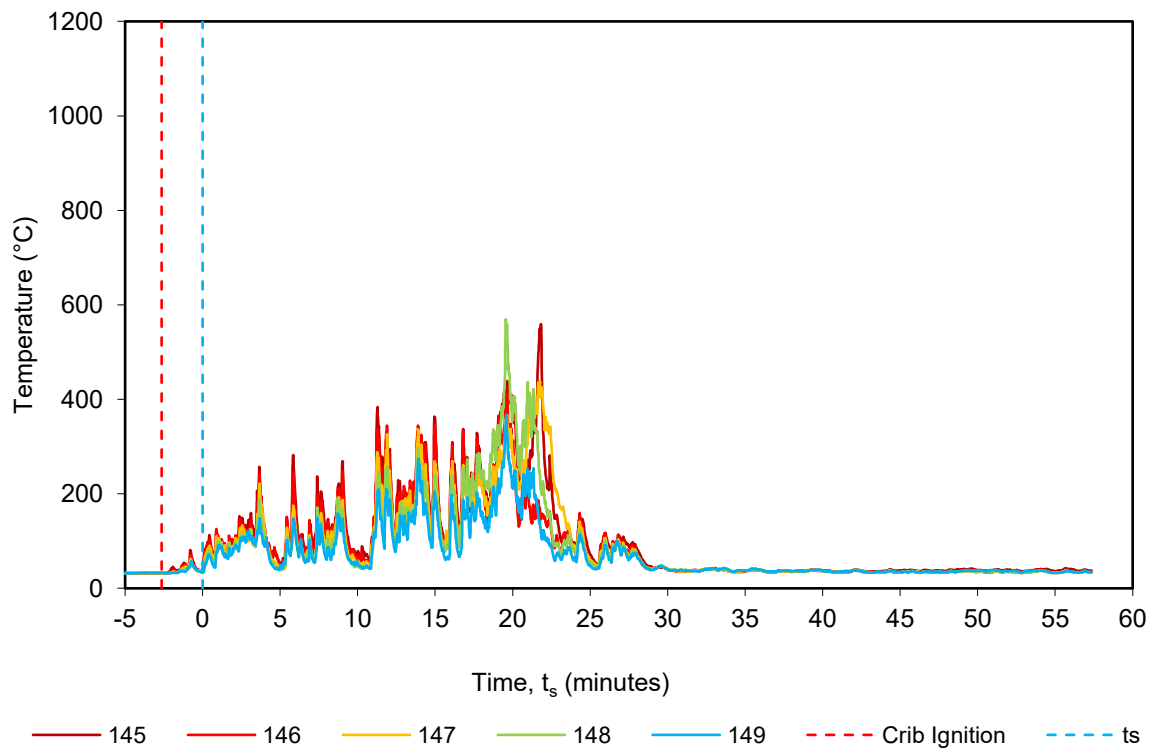

Figure 33 Left ACP thermocouples – temperature vs time

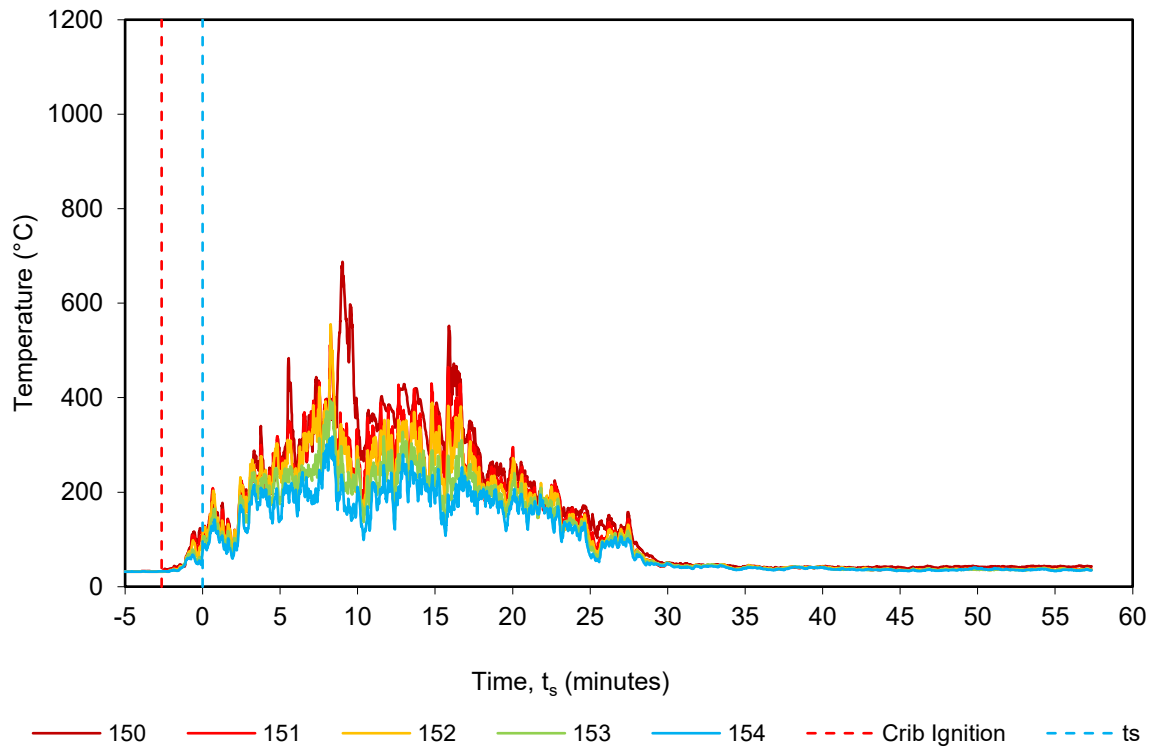

Figure 34 Right ACP thermocouples – temperature vs time

Appendix D Photographs



Figure 35 The external cladding system before the start of the test – main wall



Figure 36 The external wall system during the test – 5 minutes after crib ignition



Figure 37 The external wall system during the test – 10 minutes after crib ignition



Figure 38 The external wall system during the test – 15 minutes after crib ignition



Figure 39 The external wall system during the test – 20 minutes after crib ignition



Figure 40 The external wall system during the test – 25 minutes after crib ignition



Figure 41 The external wall system during the test – 30 minutes after crib ignition

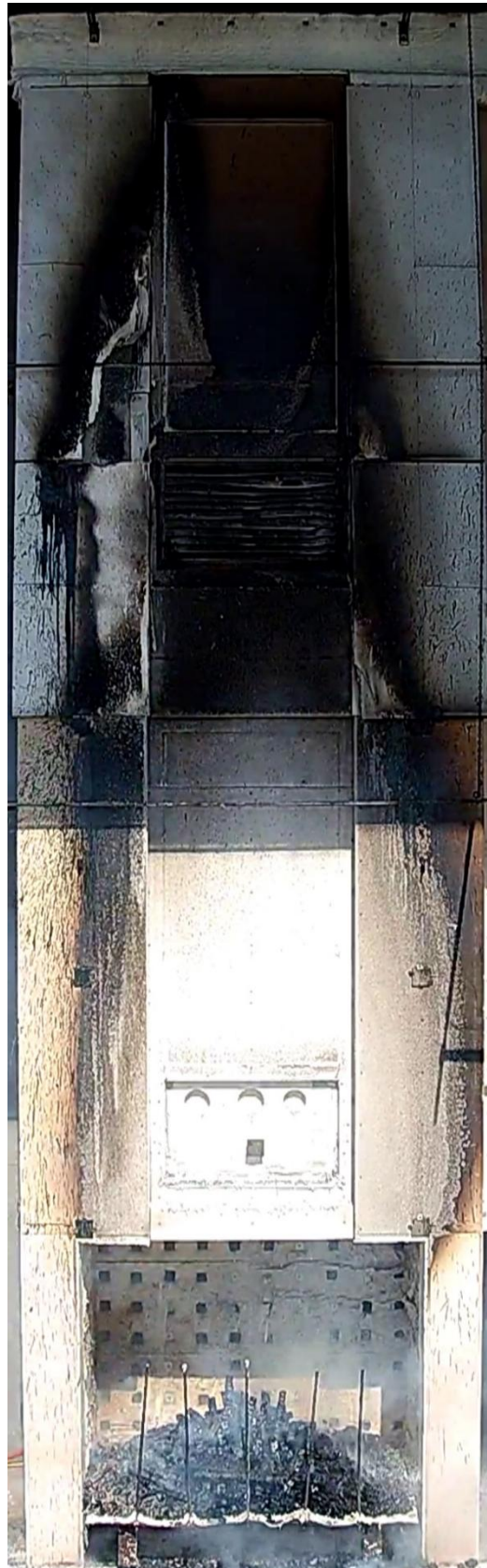

Figure 42 The external wall system during the test – during removal of the crib, 30 minutes after ignition of crib



Figure 43 The external wall system on completion of the test – main wall

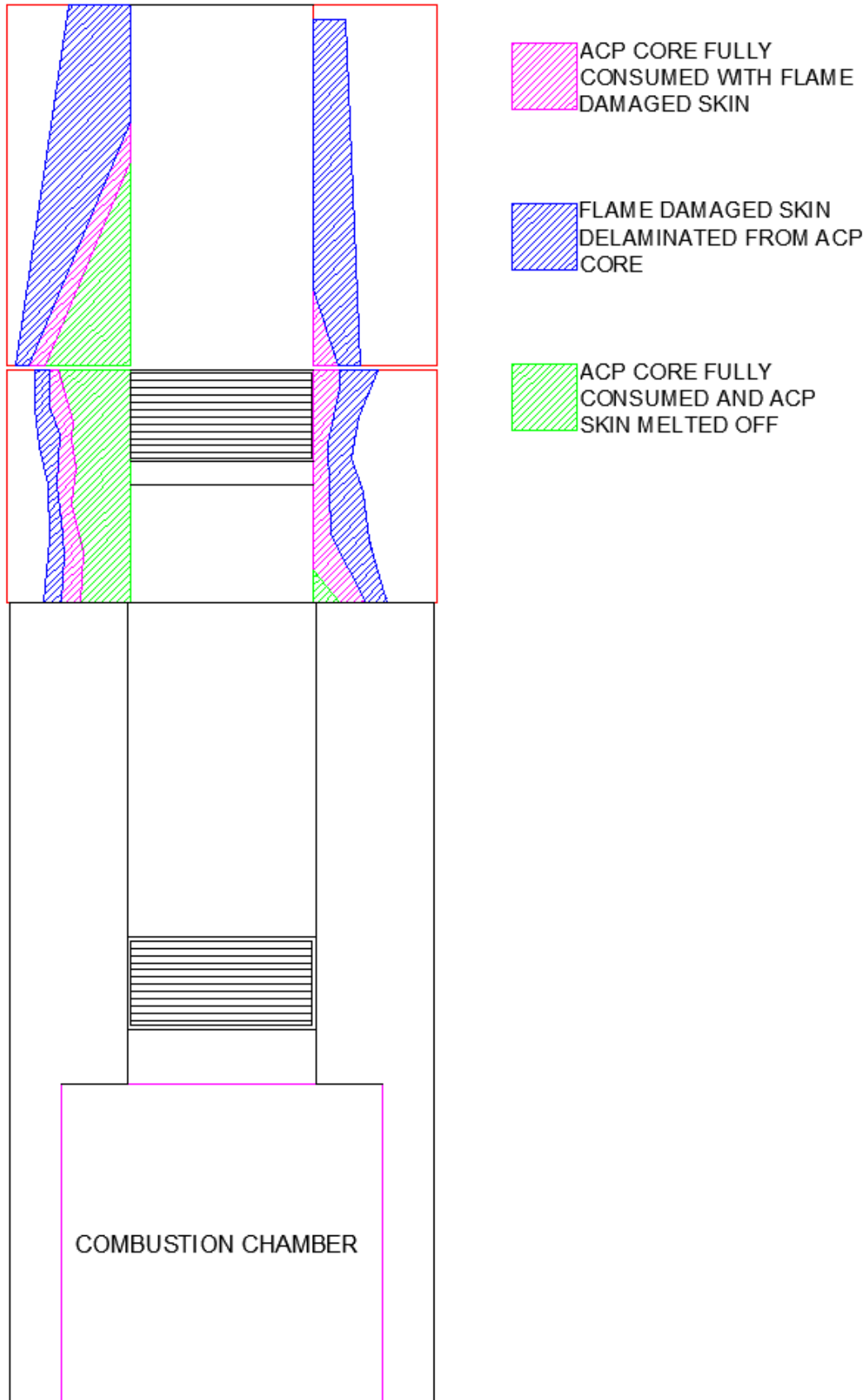

Figure 44 The post-test external wall system ACP damages – main wall

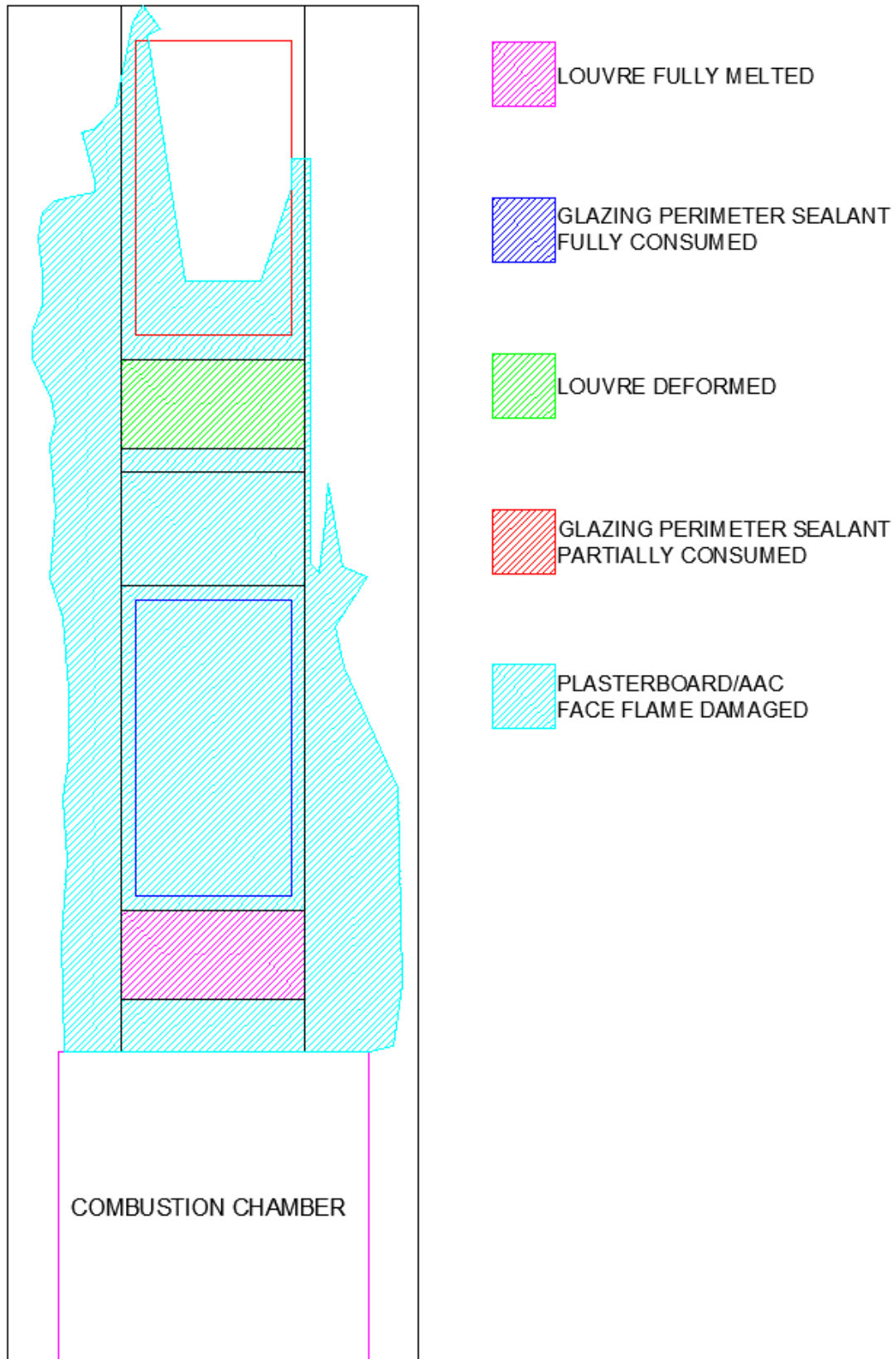

Figure 45 The post-test external wall system with the ACP removed – main wall

Appendix E Chemical analysis results



UNSW RESEARCH INFRASTRUCTURE

Chemical Consulting Laboratory

Mark Wainwright Analytical Centre
UNSW Sydney NSW 2052 Australia

T: +61(2) 9348 1400 | E: ccl@unsw.edu.au
W: www.analytical.unsw.edu.au/contact-us/commercial-consulting
ABN 57 195 873 179 | CRICOS Provider Code 00098G

Test Report

Prepared by:

ANALYSIS OF CLADDING SAMPLES

For

Company: Warrington Fire
Contact: [REDACTED]
Date: 22 February 2024

Project No: 24021

Prepared by: [REDACTED]
Approved by: [REDACTED]

COMMERCIAL-IN-CONFIDENCE

Any use of the Test Report, use of any part of it, use of the names University of New South Wales or UNSW, use of the name of any Unit of UNSW, or use of the name of the consultant in direct or indirect advertising or publicity is strictly forbidden.



Analysis of Cladding Samples

1. SAMPLES

One envelope containing three ACP cores was received for analysis. The samples were identified as follows:

CCL sample coding	Client sample coding
24021-1	#1 - 100%
24021-2	#2 - 100%
24021-3	#3 - 45% Non FR

CCL has been asked to identify the polymer and the filler (s) in the samples by FT/IR, quantitate and identify the mineral filler in the samples and classify them in accordance with the ICA cladding scheme.

2. METHODOLOGY AND RESULTS

The aluminium metals were removed from the ACPs cladding polymer, and the flat surface of the polymer sample was abraded to remove any surface adhesive. The surface of the sample was analysed directly by FTIR. The FT-IR spectra are presented in Figures 1-3.

The core of the samples was then ashed to determine their percentage mineral content (Table 1). If sufficient (>0.5 g) ash was found in the sample, it was analysed for elemental composition by X ray fluorescence spectroscopy. Results are presented in Table 2.

Table 1 Ash content of 24021-1-3

Sample coding	Ash content (w/w%)
24021-1	3.3
24021-2	3.0
24021-3	40.0

3. CONCLUSIONS

The cladding sample #1 consisted of 3.3% inert material and approximately 96% polyethylene polymer.

The cladding sample #1 is classified as ICA category A.

The cladding sample #2 consisted of 3.0% inert material and approximately 97% polyethylene polymer.

The cladding sample #2 is classified as ICA category A.

The cladding sample #3 consisted of 33.7% calcium carbonate, 5.6% magnesium hydroxide, 2.5% other inert material and approximately 58% polyethylene polymer.

The cladding sample #3 is classified as ICA category A.

The ICA Classification assigned is correct as per the September 2020 revision of the ICA Guidelines.

The reader is reminded that we can only analyse and classify the content of samples actually presented to us. We can offer no guarantee that this composition or classification is valid for cladding as a whole, because some types of cladding can be inhomogeneous, and a sample may not be representative of the cladding as a whole. Anyone using our results should consider these sampling issues and uncertainties before they generalise the results we present to anybody of cladding as a whole.

Senior Technical Officer
Chemical Consulting Laboratory
Mark Wainwright Analytical Centre, UNSW
22 February 2024



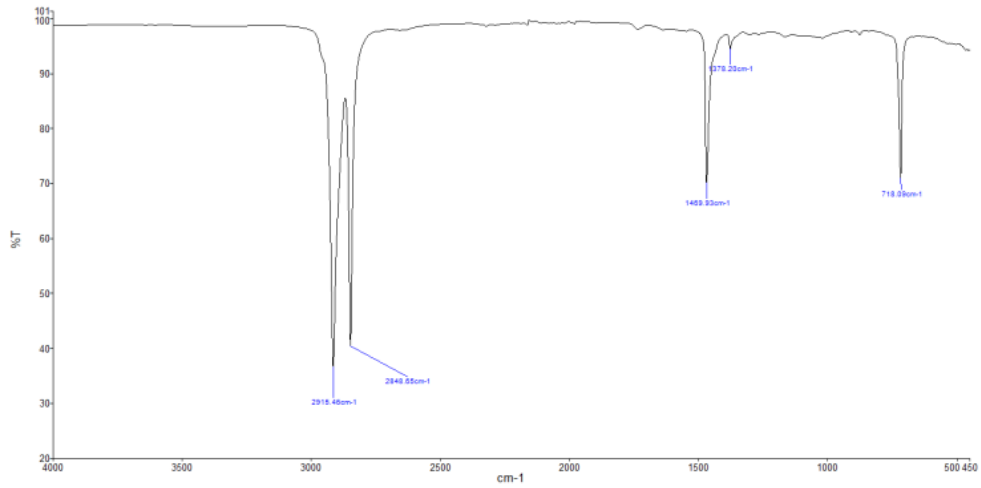

Figure 1. FT-IR spectrum of sample #1

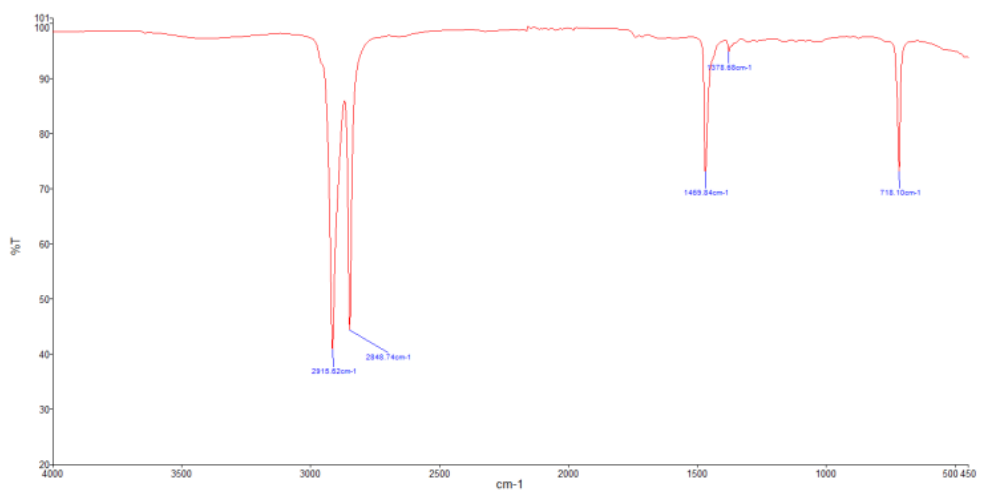

Figure 2. FT-IR spectrum of sample #2





JENSEN HUGHES

Jensen Hughes Fire Testing Pty Ltd
ABN 81 050 241 524

Perth

Suite 4.01, 256 Adelaide Terrace
Perth WA 6000
Australia
T: +61 8 9382 3844

Canberra

Unit 10, 71 Leichhardt Street
Kingston ACT 2604
Australia
T: +61 2 6260 8488

Melbourne

Level 4, 152 Elizabeth Street
Melbourne Vic 3000
Australia
T: +61 3 9767 1000

Sydney

Suite 302, Level 3, 151 Castlereagh Street
Sydney NSW 2000
Australia
T: +61 2 9411 5360

Brisbane

Suite B, Level 6, 133 Mary Street
Brisbane Qld 4000
Australia
T: +61 7 3238 1700

Melbourne – NATA accredited laboratory

409-411 Hammond Road
Dandenong South Vic 3175
Australia
T: +61 3 9767 1000

General conditions of use

The data, methodologies, calculations and results documented in this report specifically relate to the tested specimen/s and must not be used for any other purpose. This report may only be reproduced in full. Extracts or abridgements must not be published without permission from Jensen Hughes Fire Testing.

All work and services carried out by Jensen Hughes Fire Testing are subject to, and conducted in accordance with our standard terms and conditions.