



JENSEN HUGHES



Reaction to fire test report

Test standard: Ad-hoc test based off ISO 13785-1:2002

Test sponsor: Cladding Safe Victoria

System: Aluminium composite panel curtain wall system nominated as being representative of the in-situ wall located at [REDACTED] – test 3

Job number: RTF250225

Test date: 15 April 2025 Revision: RR1.0

Quality management

Revision	Date	Information about the report			
RR1.0	8 September 2025	Description	Initial issue		
		Name	Prepared by	Reviewed by	Authorised by
		Signature			

Jensen Hughes Fire Testing Pty Ltd
 ABN 81 050 241 524

Formerly Warringtonfire Australia Pty Ltd¹

¹ Warringtonfire Australia Pty Ltd was acquired by Jensen Hughes in December 2023. Jensen Hughes Fire Testing Pty Ltd is not affiliated, associated, authorised, or endorsed by Warringtonfire Australia Pty Ltd, Warringtonfire Testing and Certification Limited or its "Warringtonfire" or "Certifire" brands.

Contents

1.	Introduction	4
2.	Test specimen	4
2.1	Schedule of components	4
3.	Test procedure	11
4.	Instrumentation locations	12
5.	Test measurements and results.....	14
6.	Application of test results	25
6.1	Test limitations.....	25
6.2	Variations from the tested specimen.....	25
6.3	Uncertainty of measurements	25
Appendix A	Drawings of test assembly	26
Appendix B	Test observations	40
Appendix C	Photographs.....	42
Appendix D	Chemical Analysis Results	51

1. Introduction

This report documents the findings of the third of three ad-hoc reaction to fire tests conducted on an aluminium composite panel (ACP) curtain wall system nominated as being representative of the in-situ wall located at [REDACTED] – test 3. The test was performed on 15 April 2025 and based on the general requirements of ISO 13785-1:2002.

Jensen Hughes performed the test at the request of the test sponsor listed in Table 1.

Table 1 Test sponsor details

Test sponsor	Address
Cladding Safe Victoria	120 A'Beckett Street Melbourne VIC 3000 Australia

2. Test specimen

2.1 Schedule of components

Table 2 describes the test specimen and lists the schedule of components. These were provided by the test sponsor and surveyed by Jensen Hughes.

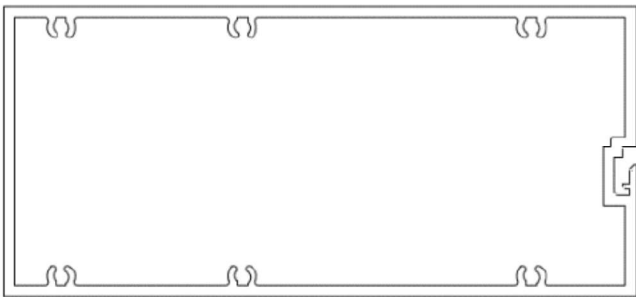
All measurements were done by Jensen Hughes – unless indicated otherwise.

Detailed drawings of the test specimen are provided in Appendix A.

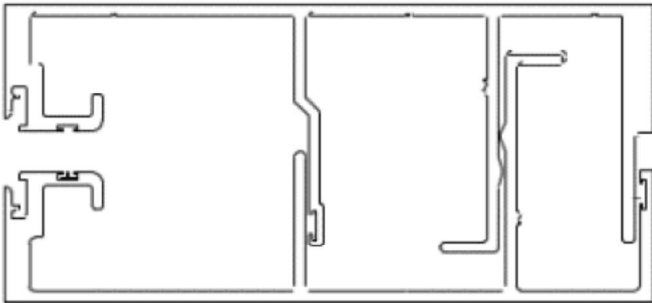
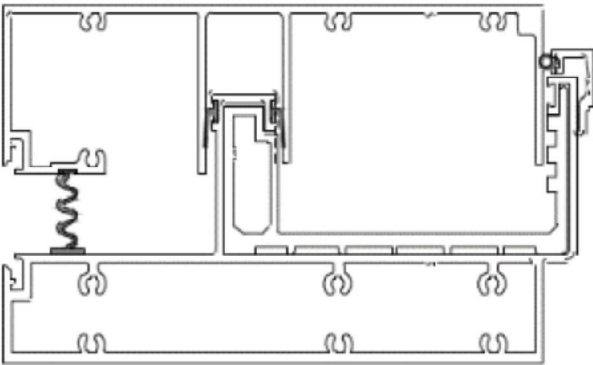

Table 2 Schedule of components

Item	Description		
Cladding			
1.	Item name	3D architectural head fixture cladding	
	Product	[REDACTED]	
	Location	Used to form the profiled head fixture (3D Shape T 2:08 TYPE Rock panel) which had overall dimensions of 1250 mm high × 1780 mm wide × 140 mm deep. Refer to Figure 22 to Figure 25 & Figure 31 for further details.	
	Supplier	[REDACTED]	
	Material	The material was nominated as panels consisting of two layers of aluminium sheets sandwiching a layer (core) with 45% polyethylene (PE) and inorganic filler. Analysis conducted by the analytical centre of UNSW showed that the core consisted of polyethylene polymer - found to be 43.3 % w/w - whilst the remainder of the material was found to be 45.7 % magnesium hydroxide, 5.7 % calcium carbonate and 5.3 % other inert material. Refer to Sample 25082-1 in Appendix D.	
		Skin finishes	Front skin – Dark brown oak pattern Back skin – Matte white
		Core colour	Light grey
Size	Total panel thickness – 4.0 mm Core thickness –2.9 mm Skin thickness – 0.5 mm (both) Refer to Appendix A for further panel sizing details.		

Item	Description	
	Date of manufacture	09/09/2016
2.	Item name	Solid aluminium cladding – Main and return wall cladding
	Product name	██████████
	Description	3 mm solid aluminium cassette fix system
	Manufacturer / supplier	██████████
	Colour	Mill Finish
	Size	Various sizes. Refer to Figure 22 to Figure 36 in Appendix A for full details.
	Installation	The solid aluminium cladding was made into a cassette – 30 mm total depth. The cassettes were secured to the aluminium framing (items 7, 8 and 9) via unequal angles (item 10) fixed through the 30 mm lip of the aluminium cassette using 10g screws (item 23). Also installed on the underside of Modules 6 and 7 next to the galvanised sheet capping (item 4) to close of the cavity.
2a.	Additional Installation	Solid aluminium panel was also used for the capping below module 7 and partial capping below Module 6.
2b.	Additional Installation	Solid aluminium panel was also used for as a slab edge cover.
3.	Item name	13 mm standard plasterboard
	Product	██████████
	Manufacturer / supplier	██████████
	Size	1200 mm wide × 13 mm thick cut to length
	Batch date	12/02/2025
	Density	670 kg/m ³
4.	Item name	Lower Module capping
	Description	0.55 BMT galvanised sheet
	Manufacturer / supplier	██████████
	Size	L-shaped: 1770 mm tall × 400 mm wide × 300 mm deep × 0.6 mm thick cut to length
	Batch date	4-Aug-2023
	Installation	Used to cap the left side (vertical edge) of Module 6 directly above the burner. Screw fixed (item 22) to the aluminium framing (item 7).
Back pan		
5.	Item name	Aluminium composite panel (ACP) panel
	Product	Aluminium Composite Panel - 4 mm White Gloss/Grey
	Location	<ul style="list-style-type: none"> Used as a back pan behind the solid aluminium cassette cladding (item 2). Used as a 50 mm wide strap to hold the insulation (item 15) in place.
	Supplier	██████████
	Note on Supply of Panel	On behalf of CSV, Jensen Hughes (formerly Warringtonfire) acquired the ACPs with 100% polyethylene core. To the best of Jensen Hughes's knowledge this is a custom production which the supplier doesn't normally supply. The panels

Item	Description	
		were provided on the basis that this was for research purposes and not any purpose other than fire testing.
	Material	The material was nominated as panels consisting of two layers of aluminium sheets sandwiching a layer (core) with 100 % polyethylene (PE). Analysis conducted by the analytical centre of UNSW showed that the core consisted of polyethylene (PE) - found to be 96% w/w - whilst the remainder of the material was found to be 3.3% inert material. Refer to Sample 24021-1 in Appendix D.
	Skin finishes	Front skin – Gloss white Back skin – Light grey
	Core colour	Black
	Size	Total panel thickness – 4.0 mm Skin thickness – 0.5 mm (both) Core thickness – 3.0 mm thick Refer to Appendix A for further panel sizing details.
	Date of manufacture	2023/12/05
	Areal density	5.6 kg/m ²
Framing		
6.	Item name	40 mm SHS Framing
	Manufacturer / supplier	██████████
	Material	Aluminium
	Size	40 mm × 40 mm × 3 mm thick
7.	Item name	Aluminium curtain wall transom/mullions (rectangular hollow sections) – framing Terminating pieces and internal
	Component	██████████
	Material	Extruded aluminium
	Size	80 mm wide × 175 mm deep × 3 mm thick 
	Manufacturer/ Supplier	██████
8.	Item name	Standard Jamb Mullion
	Components	██████████
	Material	Extruded aluminium



Item	Description	
	Size	175 mm wide × 80 mm wide × 3 mm normal thickness 
	Manufacturer/Supplier	██████████
9.	Item name	Gutter sill transom
	Components	██
	Material	Extruded aluminium
	Size	116 mm high × 180 mm deep × 2.5 mm to 3 mm thick 
	Manufacturer / supplier	██████████
10.	Item name	Aluminium unequal angle
	Material	Aluminium
	Size	25 mm × 20 mm × 1 mm thick
	Usage	Fixed to the front face of the mullions and transoms to allow fixing of the aluminium panels (items 2).
	Manufacturer/Supplier	██████████
11.	Item name	Aluminium casing
	Material	Aluminium
	Size	40 mm × 1.8 mm thick 



Item	Description	
	Usage	Clips into mullions and transoms around cladding angles (item 10) to allow sealant to be applied.
	Manufacturer/ Supplier	██████████
12.	Item name	Aluminium plate
	Material	Aluminium
	Size	40 mm × 1.8 mm thick
	Usage	Used to fix the architectural feature to module 8 using tek screws (item 22).
	Manufacturer/ Supplier	██████████
13.	Item name	Wall framing – studs
	Description	██████████
	Material	Galvanised steel
	Size	64 mm deep × 4800 mm long × 36 mm wide × thick
	Usage	Used for the steel framed plasterboard wall.
	Batch	Unknown
	Manufacturer / supplier	██████████
14.	Item name	Wall framing – nogging track used as head track
	Description	██
	Material	Galvanised steel
	Size	67 mm × 20 mm × 0.7 mm BM
	Usage	Used for the steel framed plasterboard wall.
	Batch date	5-July-2023
	Manufacturer / supplier	██████████
Insulation		
15.	Item name	Foil faced 50 mm thick mineral wool insulation
	Product Name	██
	Description	Foil face 50 mm thick mineral wool core. 1 m wide.
	Mass per unit area of blanket	2.44 kg/m ² (measured)
	Manufacturer / supplier	██████████
Sealant/Adhesive		
16.	Item name	Weathering sealant
	Product name	██
	Material	Silicone sealant
	Batch	SC2409858-8235



Item	Description	
	Manufacturer / supplier	██████████
	Usage	Placed at ACP edges and over the screw locations.
17.	Item name	Plasterboard jointing compound
	Product name	████████████████████
	Manufacturer / supplier	██████████
	Date of manufacture	Unknown
Fixings		
18.	Item name	Framing equal angle - cleat
	Manufacturer / supplier	██████████
	Size	40 mm × 40 mm × 3 mm
	Usage	Used to fix aluminium framing members together. Used in conjunction with hex-head screws (item 23)
19.	Item name	Transom screws
	Manufacturer / supplier	██████████
	Description	10g × 50 mm long wafer head self-tapping screws – Galvanised zinc alloy
	Usage	Fixing transoms to transoms
20.	Item name	Aluminium panel screws
	Manufacturer / supplier	██████████
	Description	12g × 16 mm long wafer head self-tapping screws – Galvanised zinc alloy
	Usage	Used to fix the aluminium panels to the unequal angles at 450 mm centres. Used to fix the backpan to the aluminium mullions.
21.	Item name	Plasterboard screws
	Description	6g × 25 mm long bugle head self-drilling screws
22.	Item name	Tek screws
	Manufacturer / supplier	██████████
	Description	12g × 20 mm long hex head self-tapping screws – Galvanised zinc alloy
	Usage	Used to fix the cleats to the aluminium framing.
23.	Item name	Framing screws
	Description	10g × 16 mm long wafer head self-drilling screw
	Usage	Used to fix the wall framing members together
Fire rated board		
24.	Item name	15 mm thick fibre reinforced mineral board
	Product name	████████████████████
	Size	790 mm wide × 1220 mm high × 15 mm thick
	Density	840 kg/m ³

Item	Description	
	Manufacturer / supplier	██████████
Test Rig and Jig		
25.	Item name	Steel Jig
	Size	The steel Jig was 6900 mm high × 2835 mm wide for the main wall and 6900 mm high × 2133 mm wide for the wing wall
	Description	The jig consisted of: <ul style="list-style-type: none"> - SHS units as the main support - two simulated concrete slab floor levels constructed mainly of steel framing and 15 mm thick mineral board (item 24). - a simulated concrete pillar – connecting the simulated slab levels - constructed mainly of steel framing and mineral board (item 24).
26.	Item name	Steel substrate
	Size	The steel substrate was 9300 mm high × 3245 mm wide for the main wall and 9300 mm high × 2000 mm wide for the wing wall
	Description	The substrate consisted of structural steel sections and square hollow sections (SHS).
Installation method		
Specimen overall size		6300 mm tall × 2835 mm wide main wall and 2133 mm wide for the wing wall.
Main wall size		4000 mm high × 1700 mm wide × 300 mm deep (not including recess width)
Return wall size		4000 mm high × 1575 mm wide × 300 mm deep
Recess size		4000 mm high × 175 mm wide × 470 mm deep
Profiled head fixture size		1250 mm high × 1780 mm wide × max. 165 mm depth

Table 3 lists the installation details for the test specimen.

Table 3 Installation details

Item	Detail
The tested system was a refurbished system from test RTF250224 tested on the 10 April 2025. After the test an inspection showed that damage was contained to Modules 6 and 7. Therefore these were replaced by representatives of the test sponsor. The blanking wall, lower module capping and some plasterboard associated with these modules were also replaced.	
Receipt date of Modules 6 and 7	11 April 2025
Installation of Module 6 and 7	11 April 2025
Completion date for construction of the test specimen on test site	14 April 2025
External wall system constructed by	Representatives of the test sponsor
Symmetry	Asymmetrical: due to the exposed face of the façade system clad with a solid aluminium panel and the unexposed side lined with 13 mm thick fire rated plasterboard. It was confirmed that the system was exposed to fire from the side that would normally face the outside of the building.



3. Test procedure

Table 4 details the test procedure for this fire resistance test.

Table 4 Test procedure

Item	Detail
Statement of compliance	<p>The ad-hoc test was based on the general principles outlined in ISO 13785-1:2002 and was performed to determine the reaction to fire performance of an external wall cladding when exposed to heat from a simulated external fire with flames impinging directly upon a façade. The test utilised a modified burner to that outlined in ISO 13785-1:2002. The burner opening was reduced to 800 mm long × 100 mm wide. There were any other variations such as specimen size, instrumentation types and locations that varied from ISO 13785-1:2002.</p> <p>The specimen was constructed in a manner representative of the in situ external curtain wall detail being evaluated for the building located on [REDACTED]</p>
Sampling / specimen selection	<p>The laboratory was not involved in sampling or selecting the test specimen for the reaction to fire test.</p> <p>The results obtained during the test only apply to the test samples as received and tested by Jensen Hughes.</p>
Test duration	60 minutes
Ambient laboratory temperature	30 °C
Instrumentation and equipment	<ul style="list-style-type: none"> Mineral insulated metal sheathed (MIMS) Type K thermocouples with an overall diameter of 1.5 mm with the measuring junction insulated were used to measure temperatures inside and outside of the specimen. Backpan thermocouples were placed in contact with the backpan with mechanical fixing to the specimen aluminium framing at least one at one point and taped (aluminium foil) to the backpan at least 25 mm from the tip. Backpan thermocouples were inherently covered by the foil faced mineral wool insulation. Cavity thermocouples were placed mid-depth of the cavity between the plasterboard and mineral wool insulation. External thermocouples were placed central to the recess of module 3 and 60 mm from the cladding of the back ACP of the recess. Two heat flux gauges were placed at the top of module 8 at either end, 25 mm from the front face of the cladding. Refer to Figure 1 & Figure 2 for further details on positioning. The fire source was a propane (95% purity) gas burner 1.2 m long × 0.1 m deep × 0.15 m tall with a reduced exposure length at the top of 0.8 m long. The burner was placed on the floor below the specimen and in contact with the exposed face of the specimen.
Test exposure	<ul style="list-style-type: none"> Five minutes of baseline data was collected prior to burner ignition. The temperature and heat flux data were collected at 5 s intervals. The heat output from the burner was maintained at 100 kW for the first 15 minutes and then changed to 300 kW for another 25 minutes of the test. The burner was then turned off and data measured for a further 20 minutes.
Test number	Test 3 of a series of 3 tests.

4. Instrumentation locations

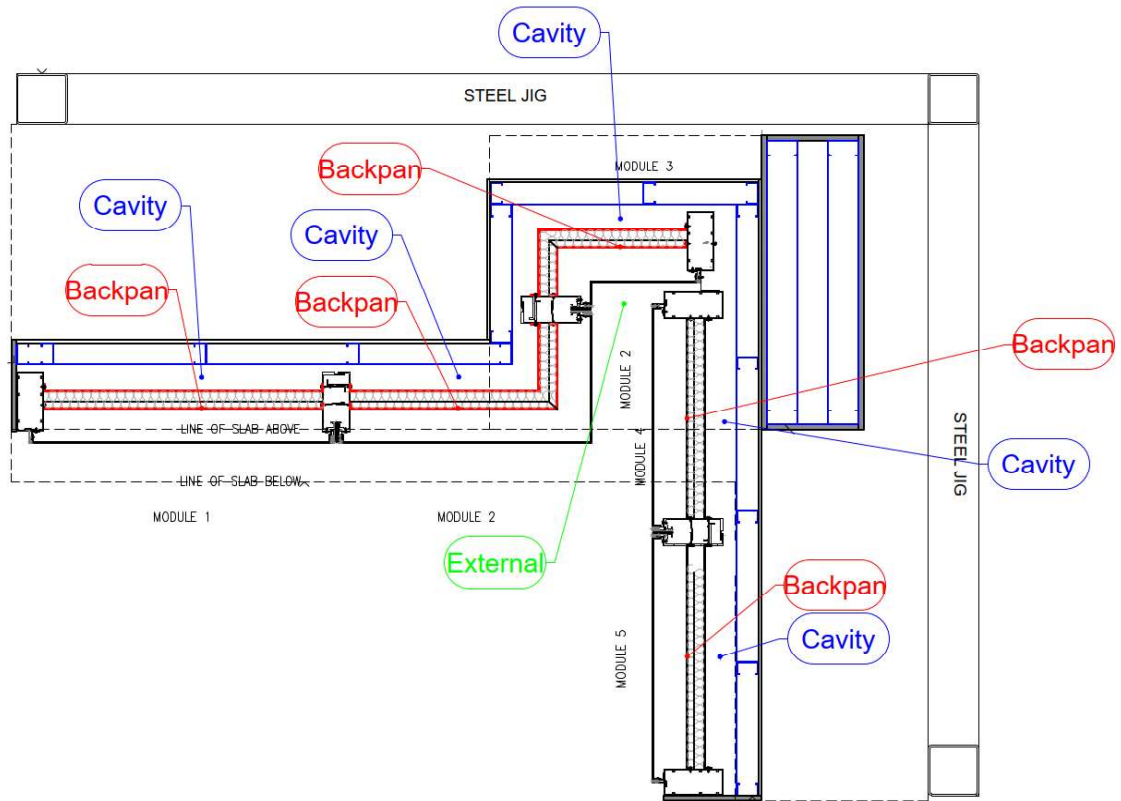


Figure 1 Instrumentation locations (plan view)

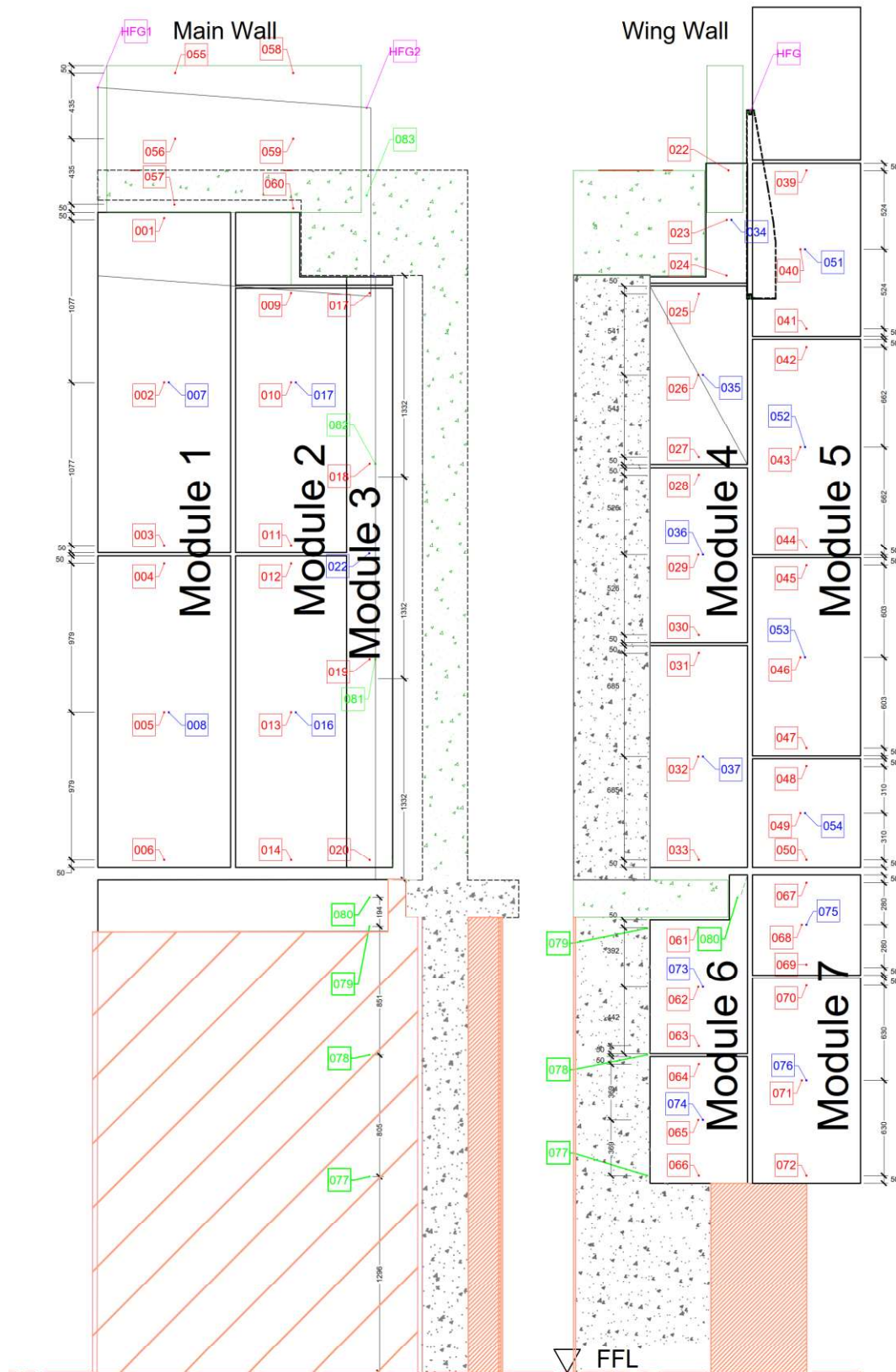


Figure 2 Instrumentation locations (elevation view)

5. Test measurements and results

The measurements from the test are summarised below.

Table 5 in Appendix B includes observations of any significant behaviour of the specimen.

Photographs of the specimen are included in Appendix C.

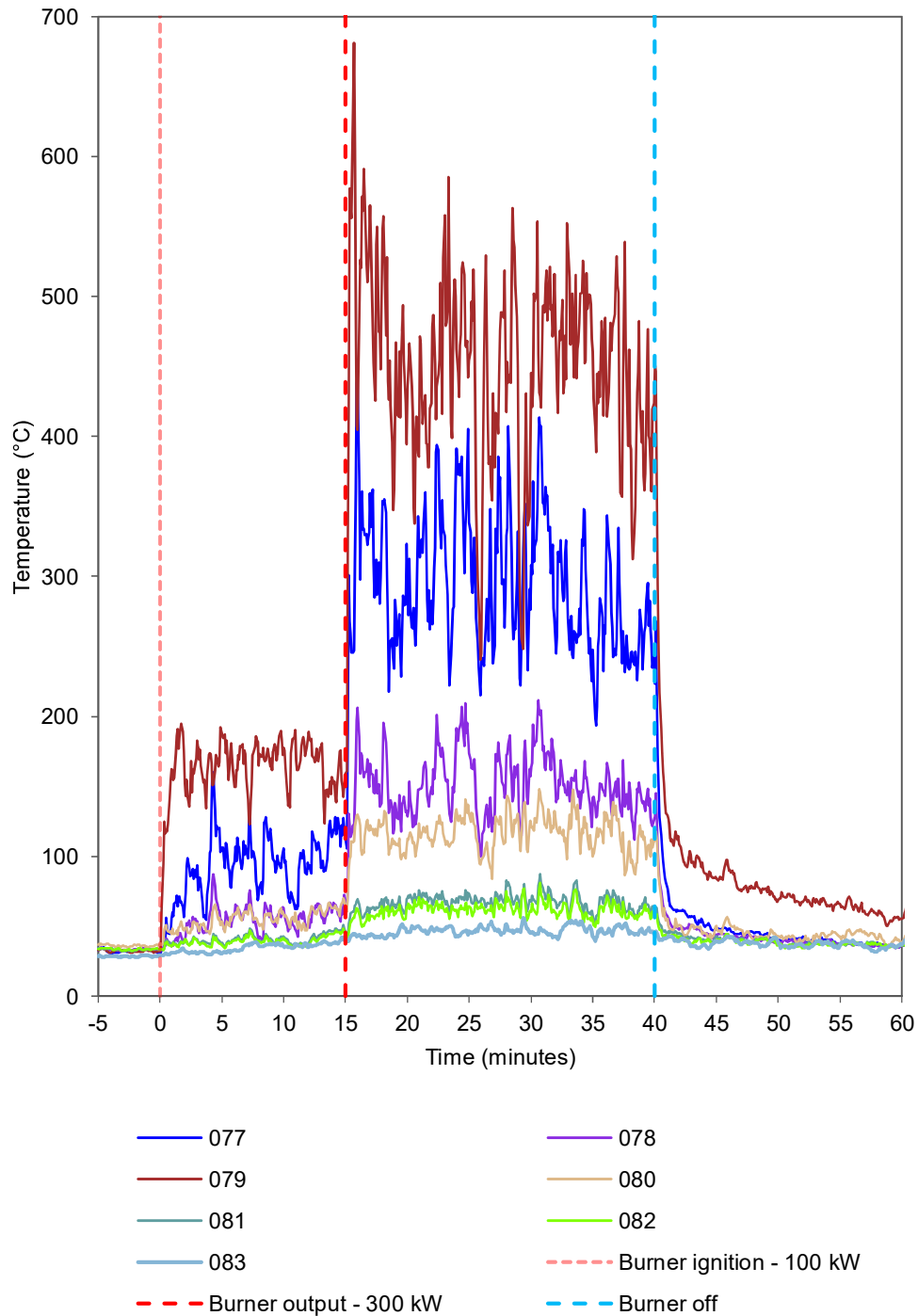


Figure 3 External temperatures - Temperature vs. time.

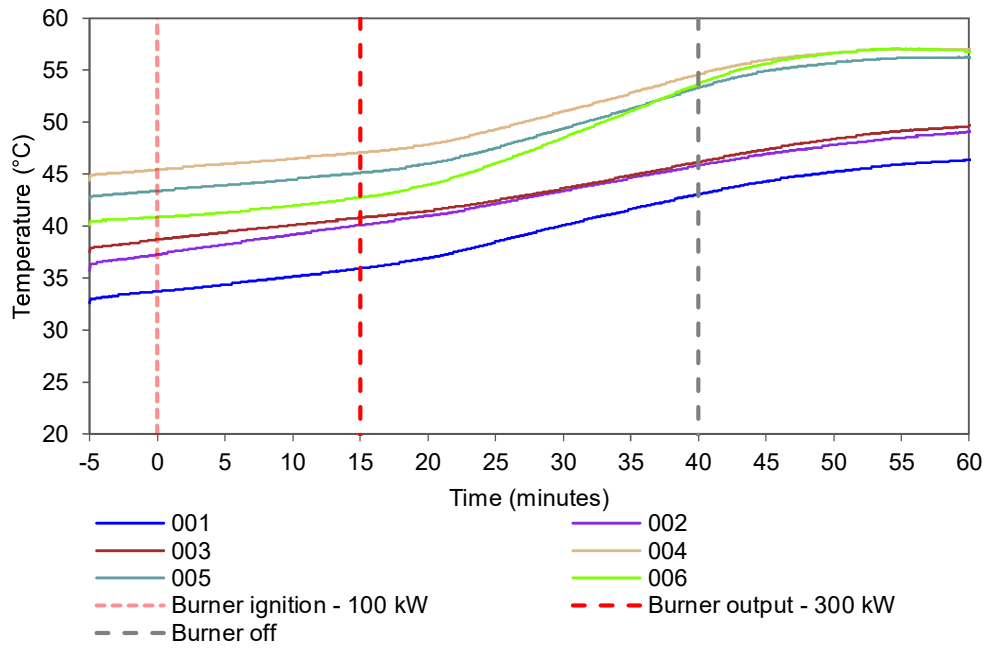


Figure 4 Internal temperatures of the back pan of module 1 - Temperature vs. time.

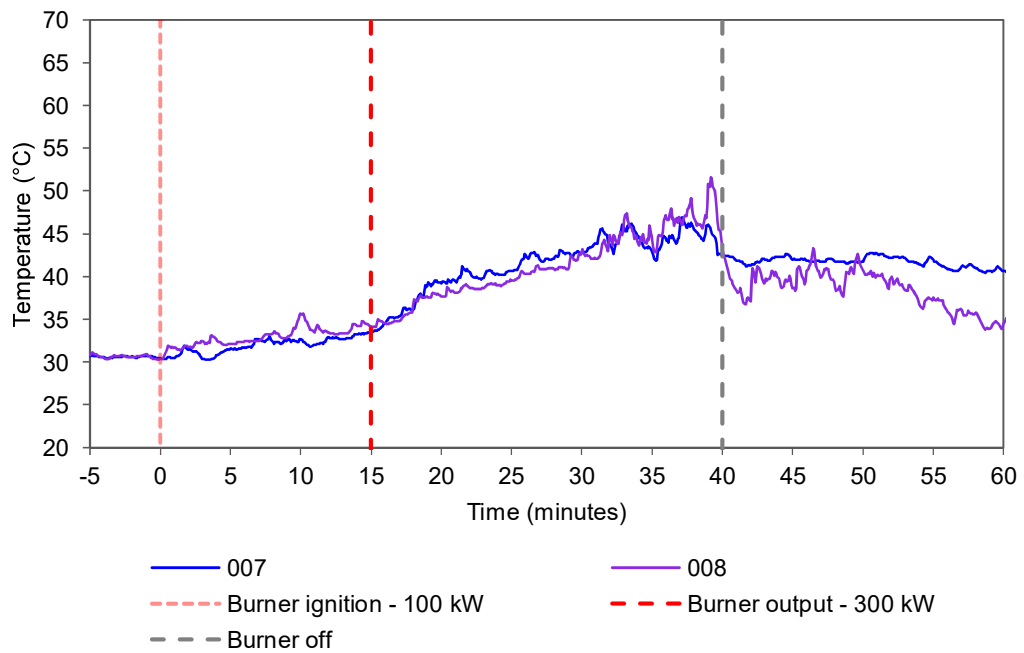


Figure 5 Internal temperatures of the cavity of module 1 - Temperature vs. time.

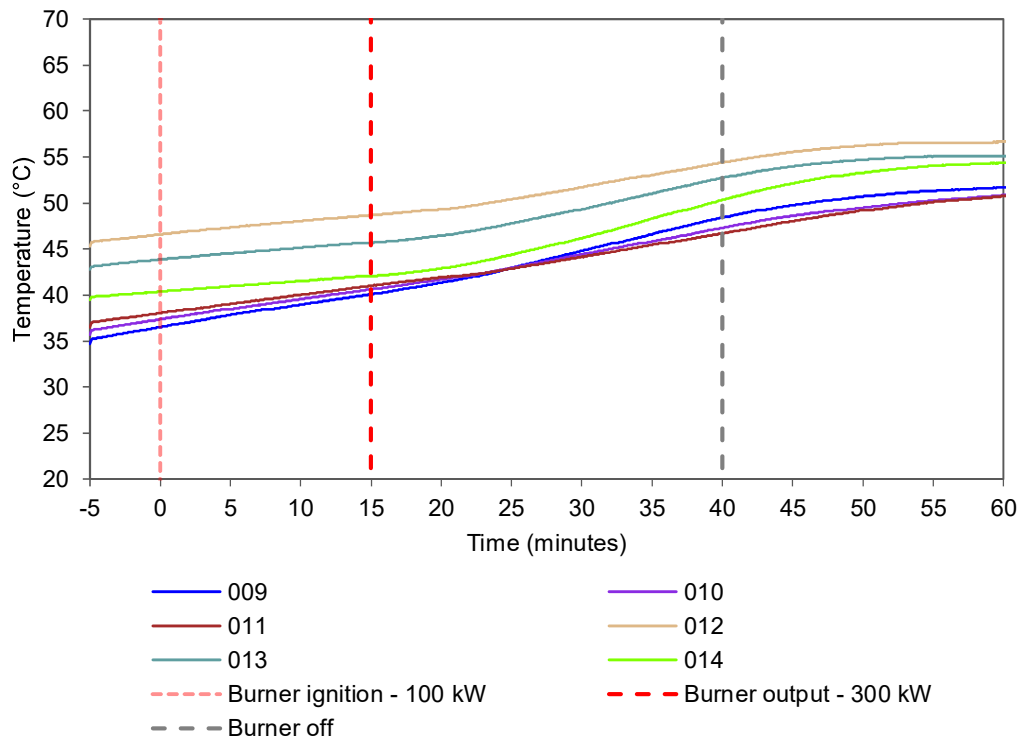


Figure 6 Internal temperatures of the back pan of module 2 - Temperature vs. time.

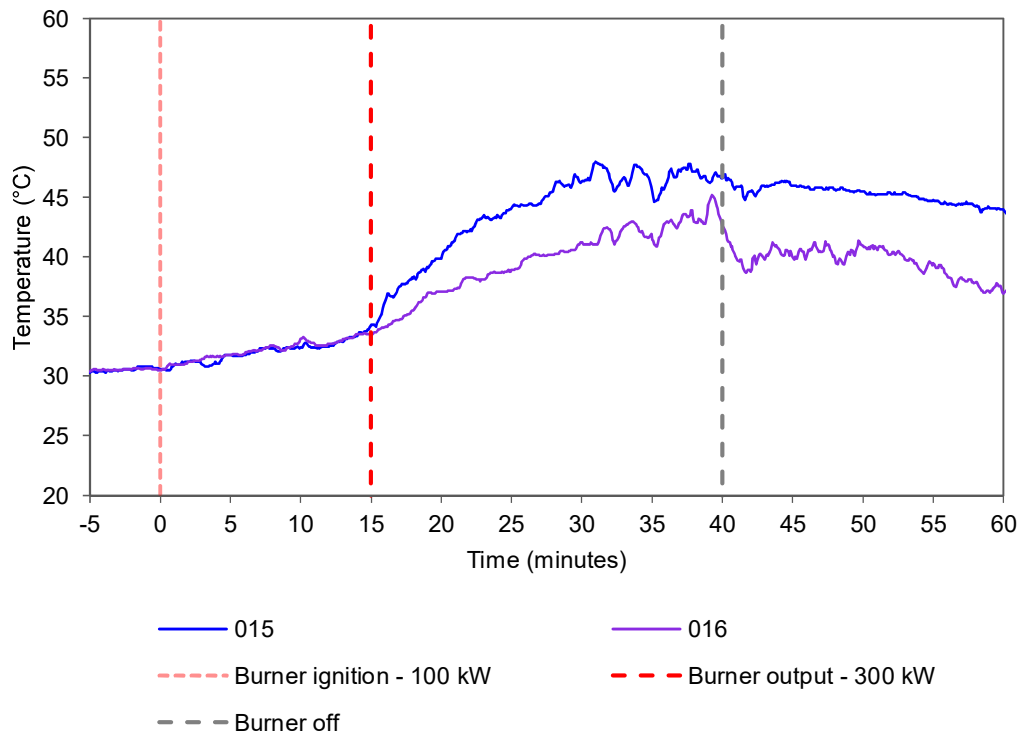


Figure 7 Internal temperatures of the cavity of module 2 - Temperature vs. time.

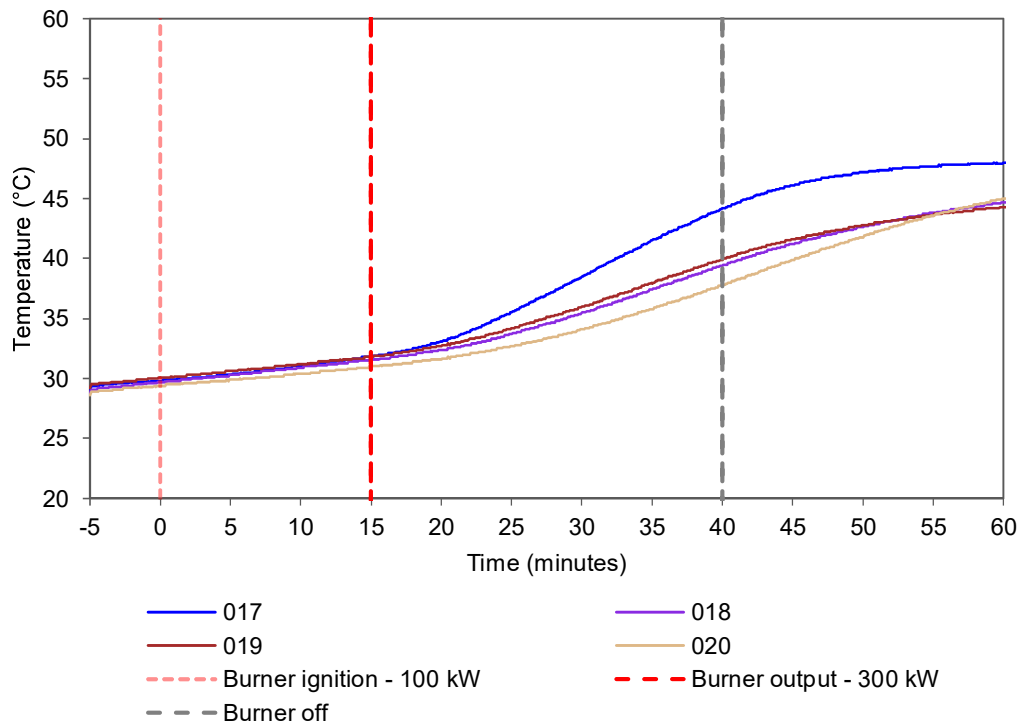


Figure 8 Internal temperatures of the back pan of module 3 - Temperature vs. time.

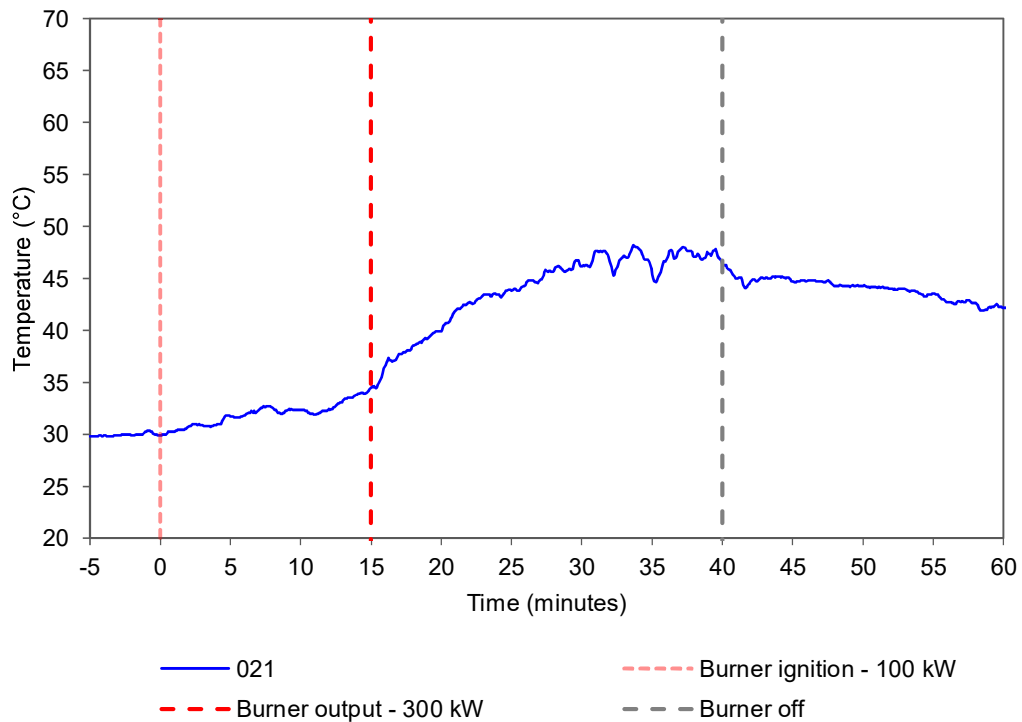


Figure 9 Internal temperature of the cavity of module 3 - Temperature vs. time.

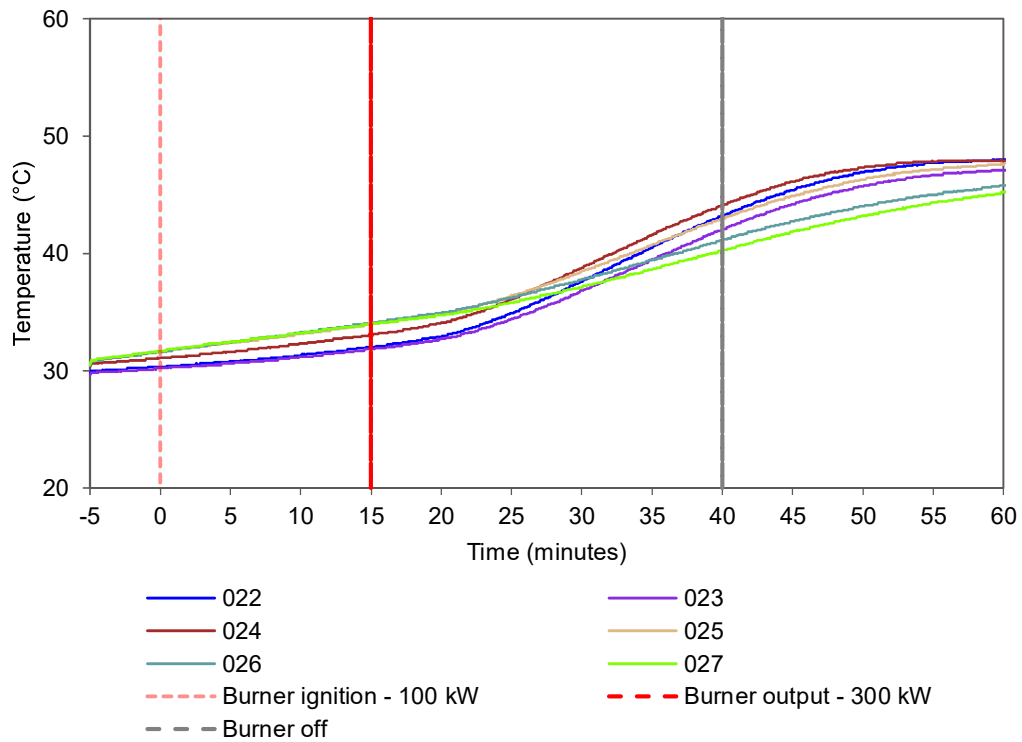


Figure 10 Internal temperatures of the back pan of module 4 (upper part) - Temperature vs. time.

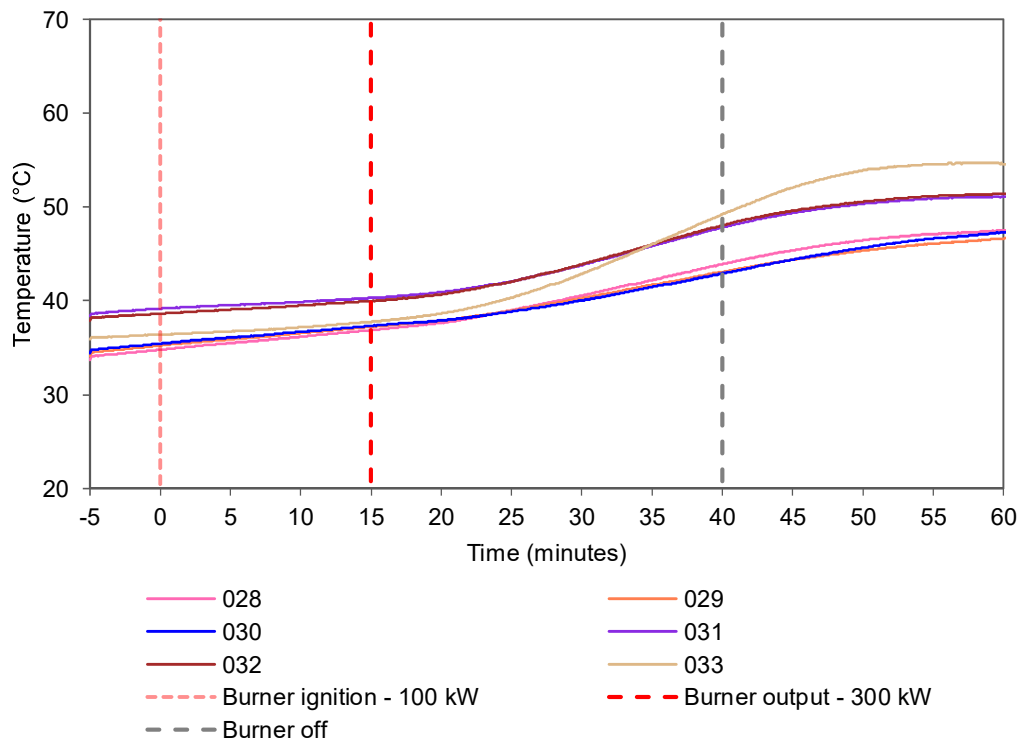


Figure 11 Internal temperatures of the back pan of module 4 (lower part) - Temperature vs. time.

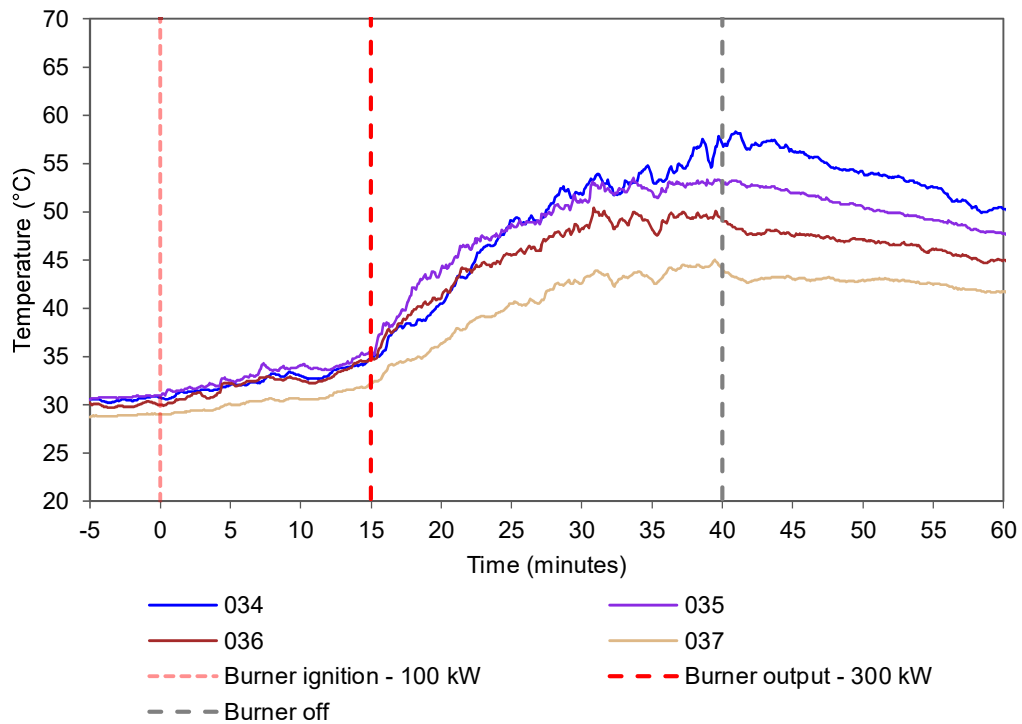


Figure 12 Internal temperatures of the cavity of module 4 - Temperature vs. time.

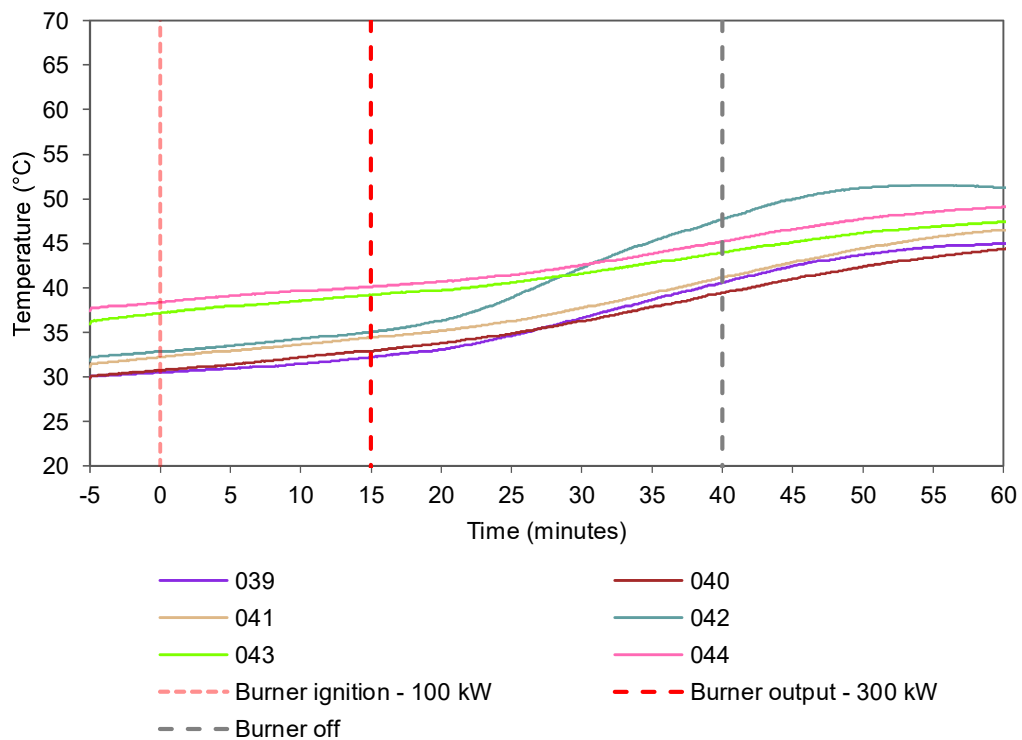


Figure 13 Internal temperatures of the back pan of module 5 (upper part) - Temperature vs. time.

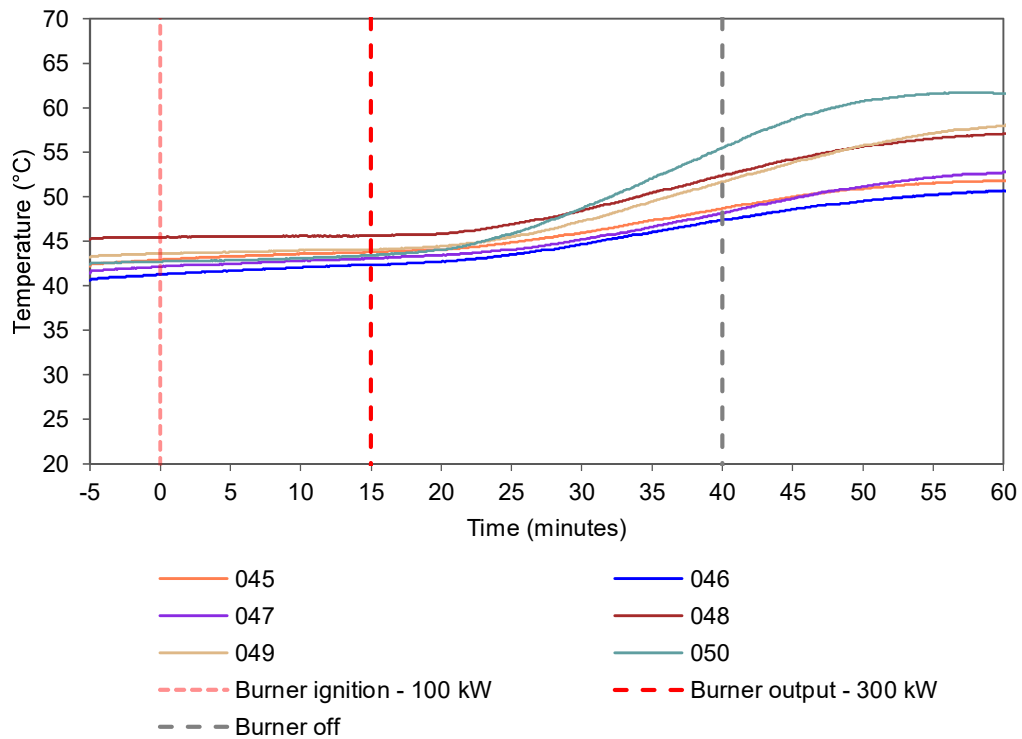


Figure 14 Internal temperatures of the back pan of module 5 (lower part) - Temperature vs. time.

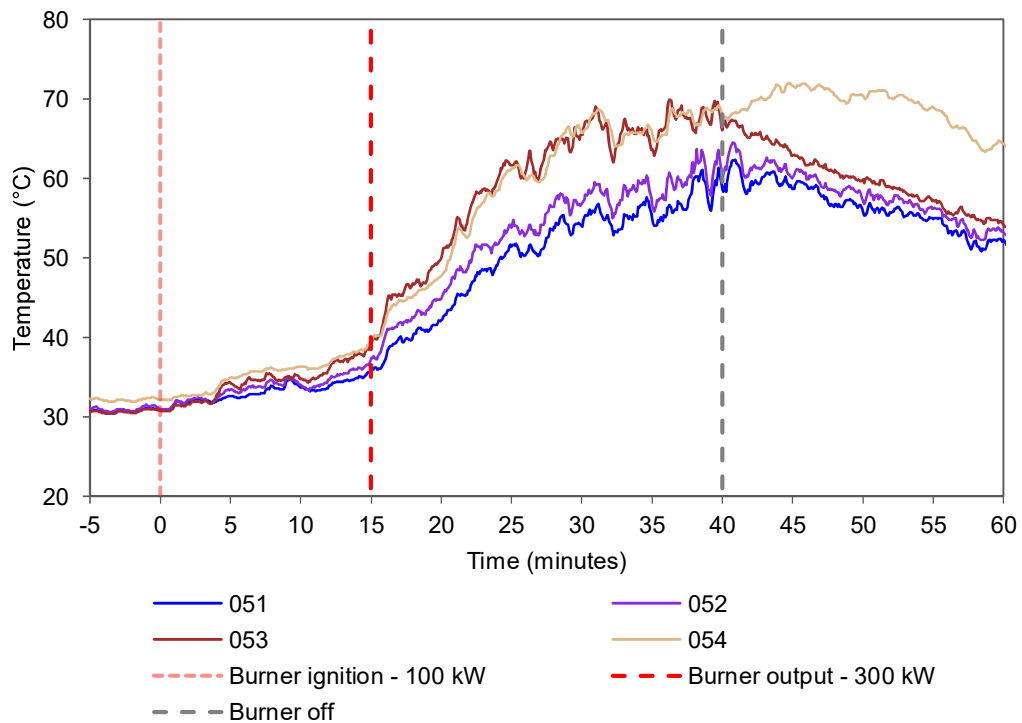


Figure 15 Internal temperatures of the cavity of module 5 - Temperature vs. time.

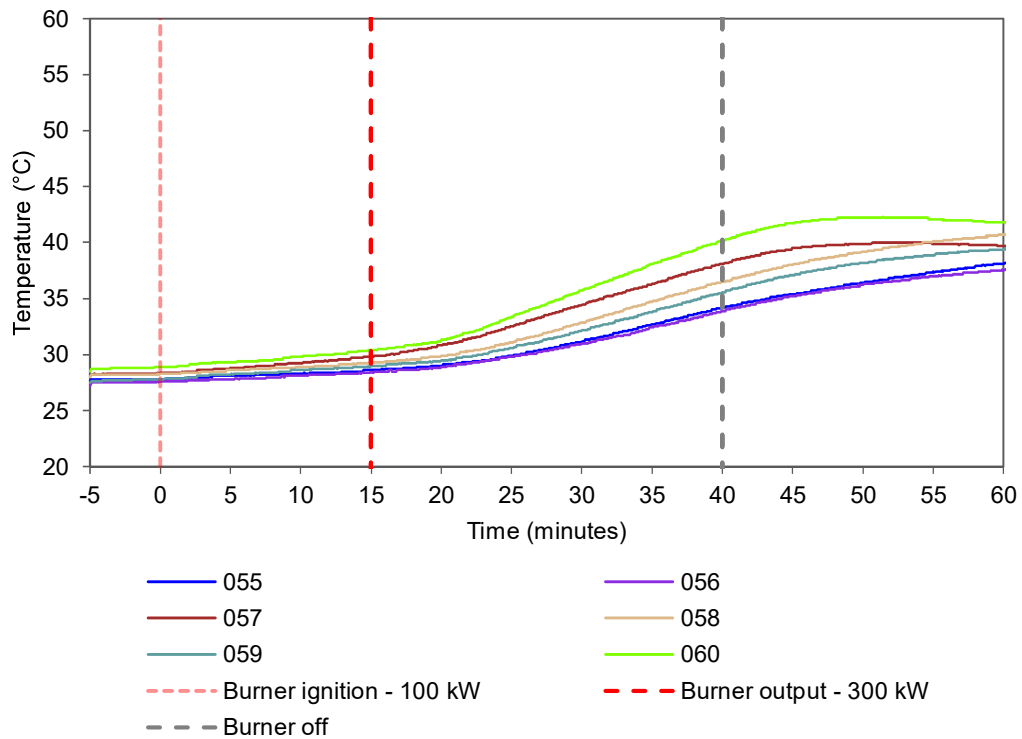


Figure 16 Internal temperatures of the back pan of module 8 - Temperature vs. time.

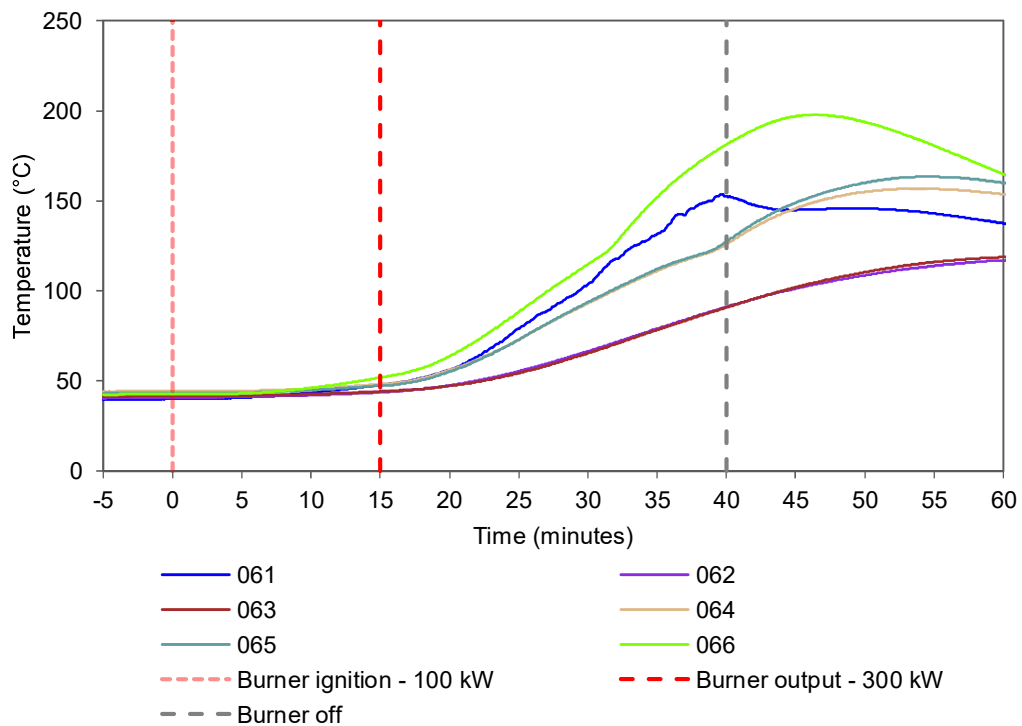


Figure 17 Internal temperatures of the back pan of module 6 - Temperature vs. time.

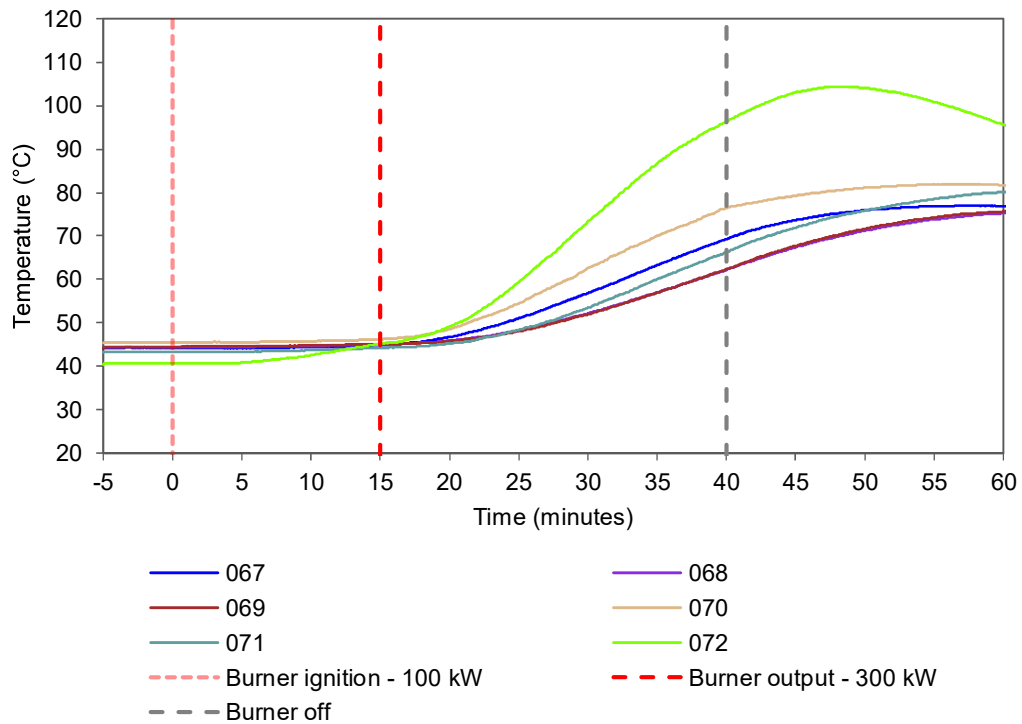


Figure 18 Internal temperatures of the back pan of module 7 - Temperature vs. time.

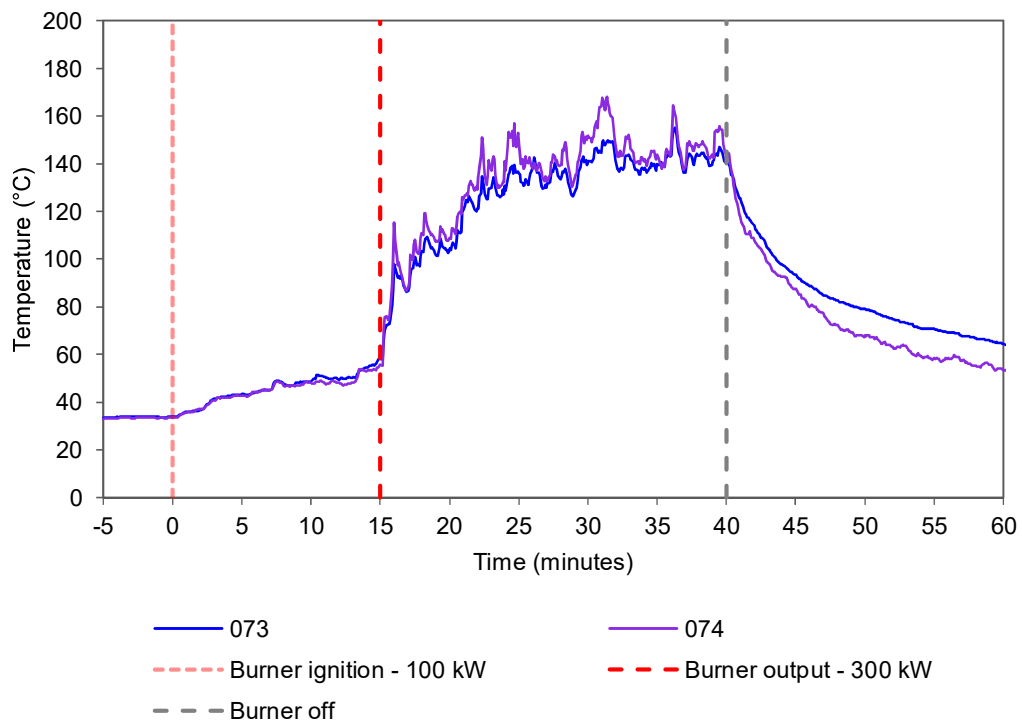


Figure 19 Internal temperatures of the cavity of module 6 - Temperature vs. time.

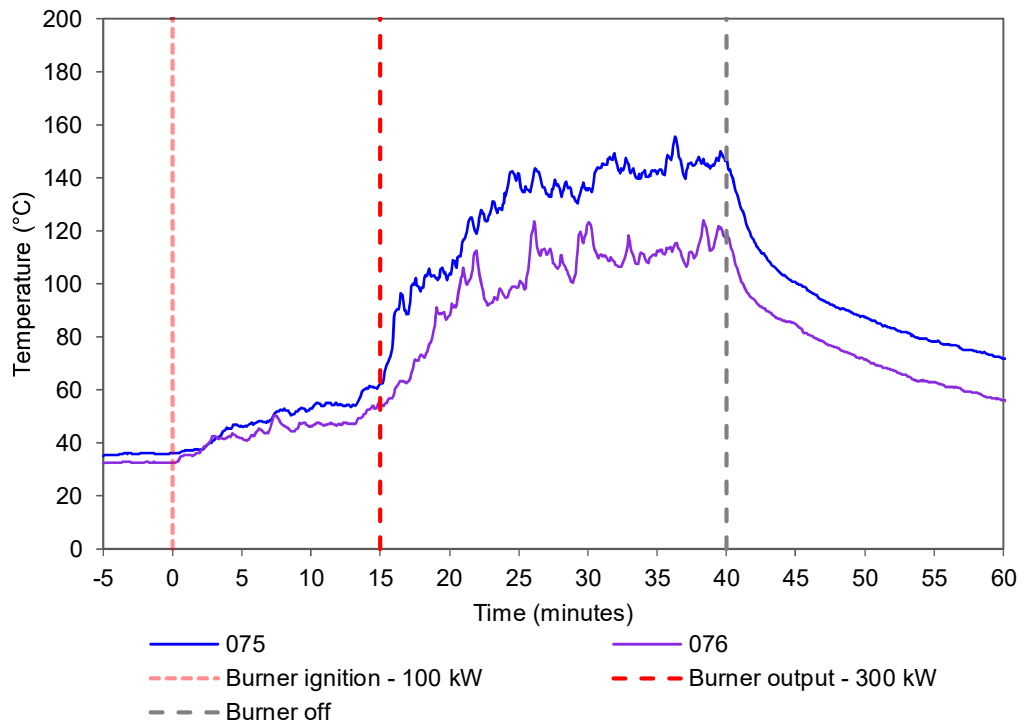


Figure 20 Internal temperatures of the cavity of module 7 - Temperature vs. time.

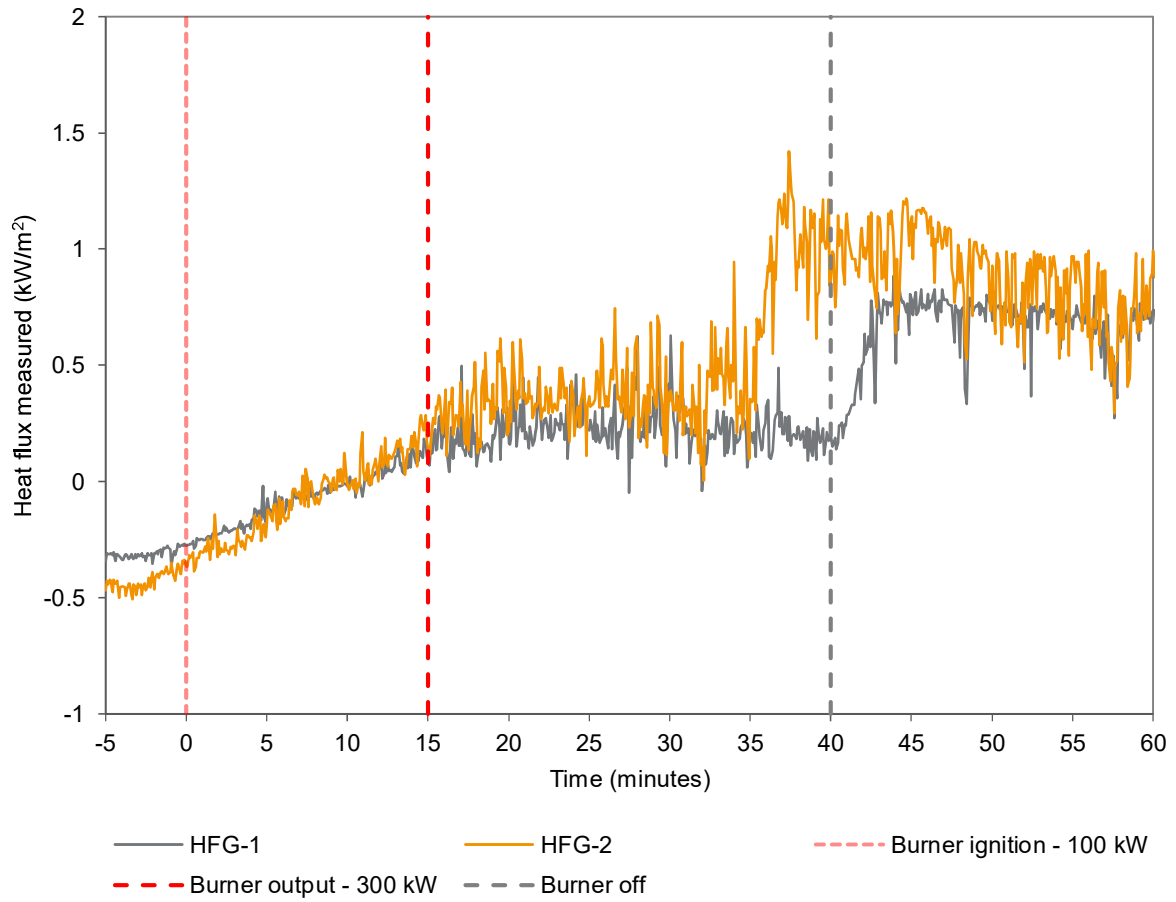


Figure 21 Measured heat flux data collected by the HFGs – Heat flux vs time.

6. Application of test results

6.1 Test limitations

The results of these fire tests may be used to directly assess fire hazard, but it should be recognised that a single test method will not provide a full assessment of fire hazard under all fire conditions.

These results only relate to the behaviour of the specimen of the element of construction under the particular conditions of the test. They are not intended to be the sole criteria for assessing the potential fire performance of the element in use, and they do not necessarily reflect the actual behaviour in fires.

6.2 Variations from the tested specimen

This report details methods of construction, the test conditions and the results obtained when the specific element of construction described here was tested following the procedure outlined in Table 4. Any significant variation with respect to size, construction details, loads, stresses, edge or end conditions is not addressed by this report.

It is recommended that any proposed variation to the tested configuration should be referred to the test sponsor. They should then obtain appropriate documentary evidence of compliance from Warringtonfire or another accredited testing authority.

6.3 Uncertainty of measurements

Because of the nature of reaction to fire testing and the consequent difficulty in quantifying the uncertainty of measurements obtained from a reaction to fire test, it is not possible to provide a stated degree of accuracy of result.

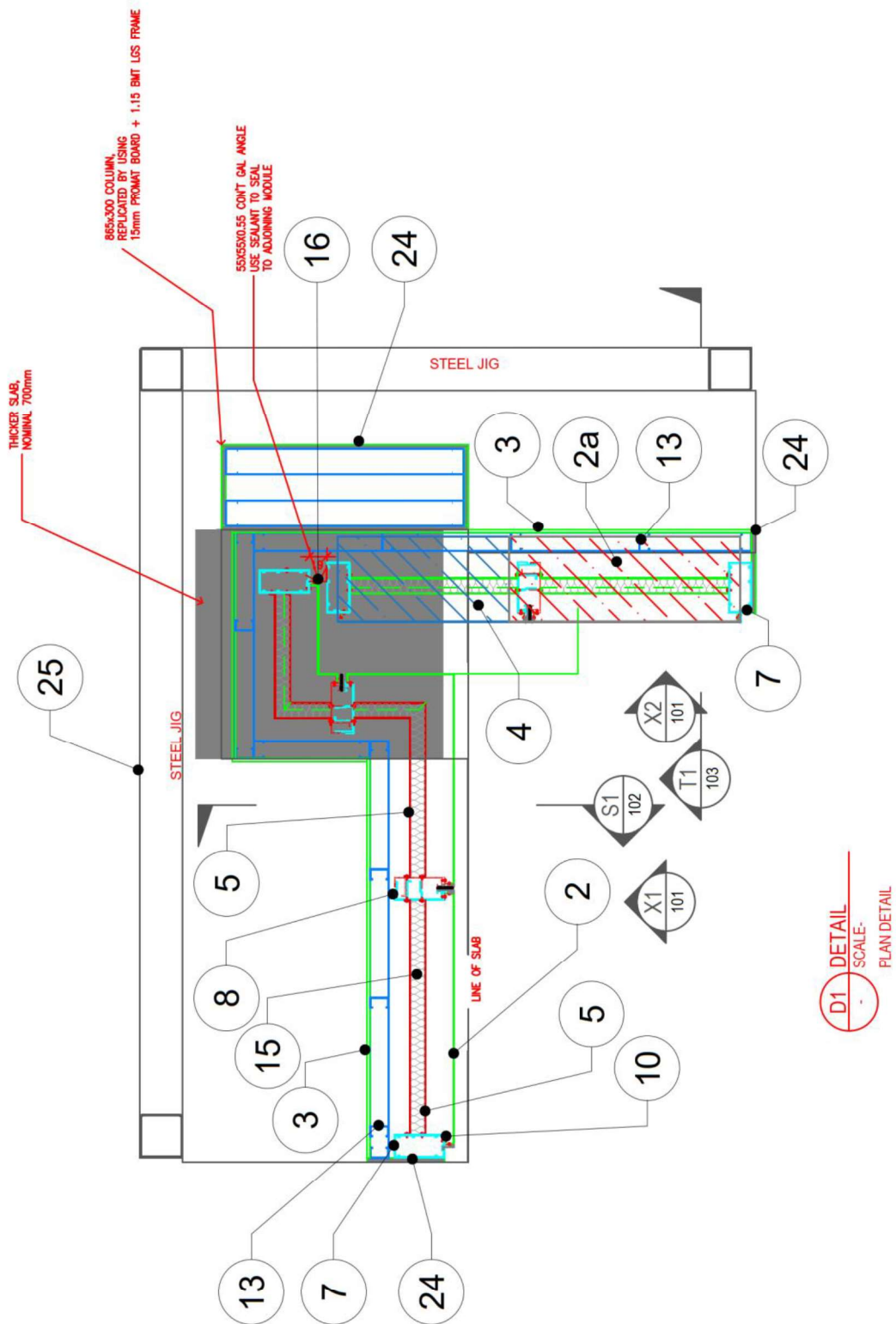


Figure 24 Plan view of the external wall – layout with leaders.

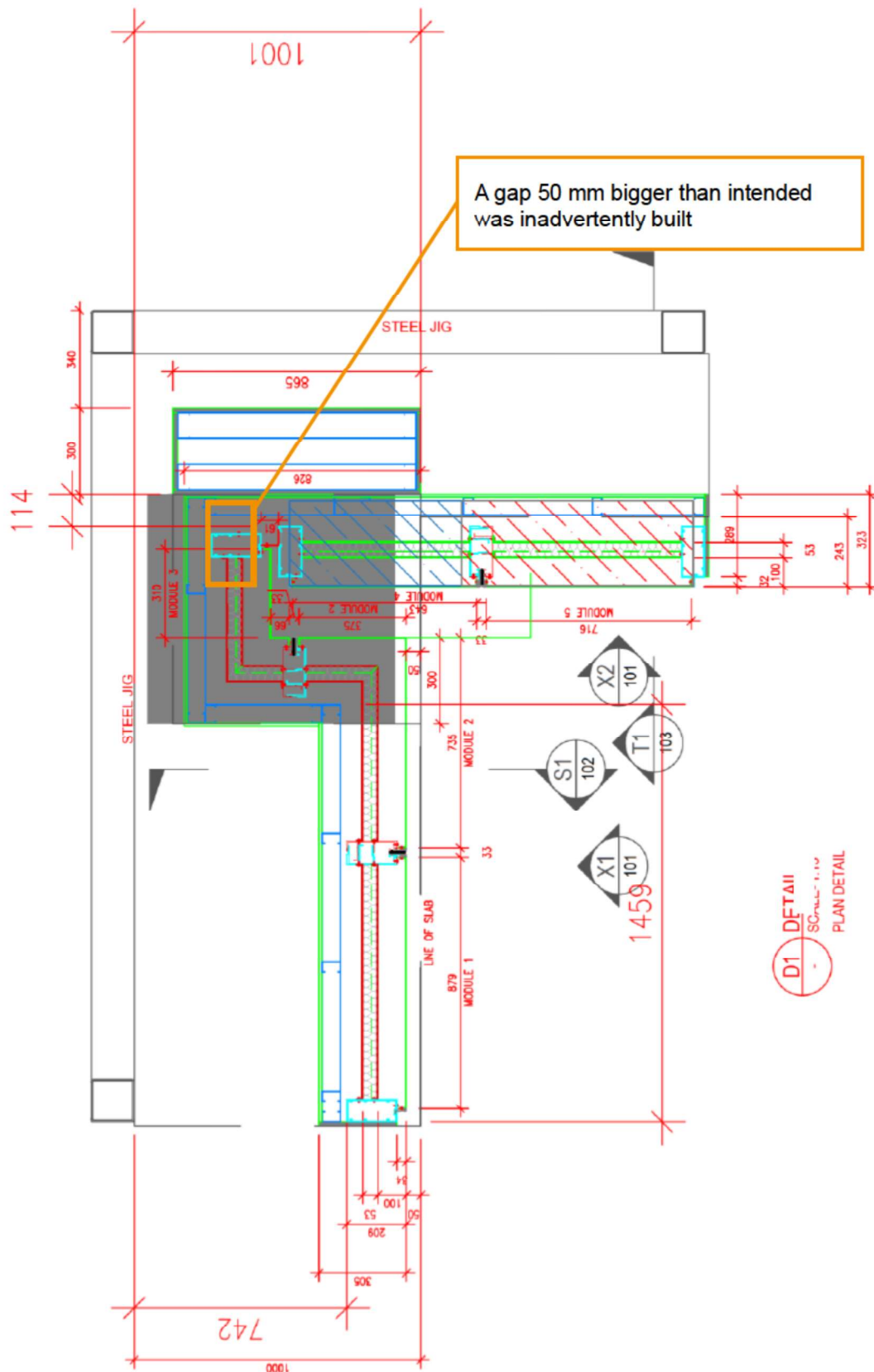


Figure 25 Plan view of the external wall – layout with dimensions.

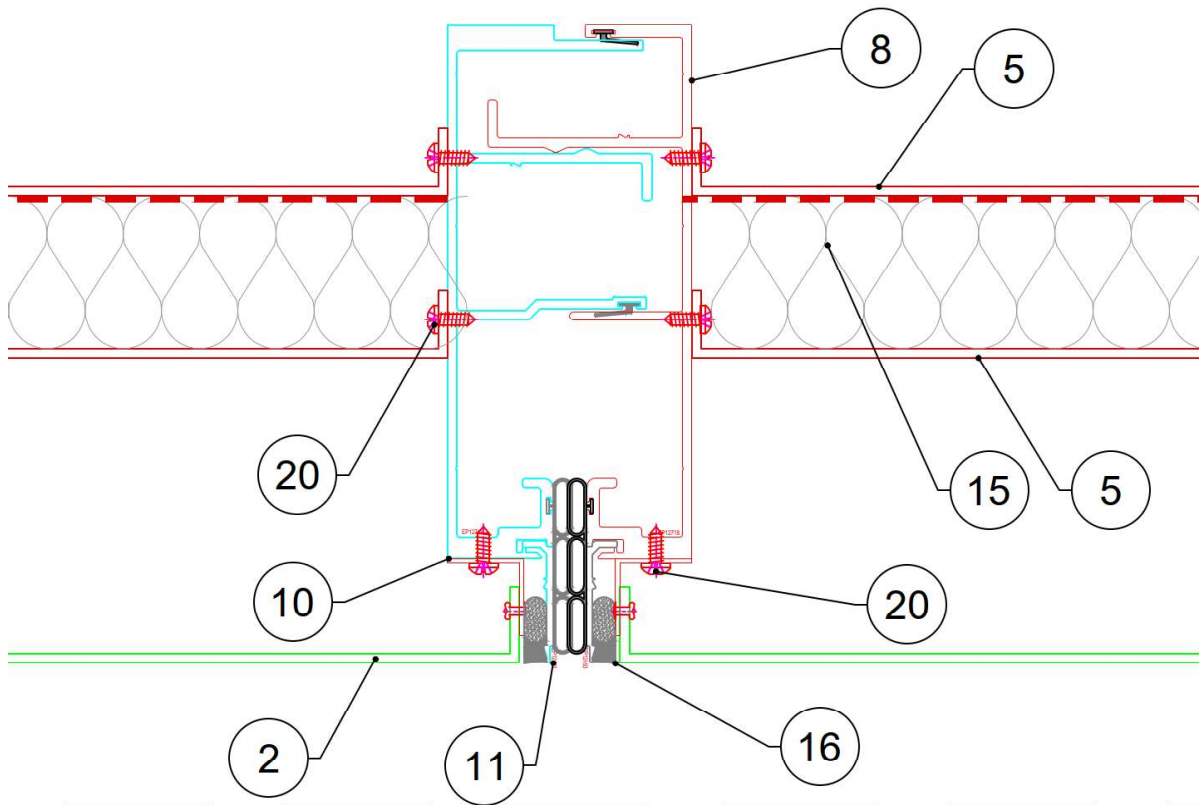


Figure 26 Horizontal cross-section of module-to-module joint.

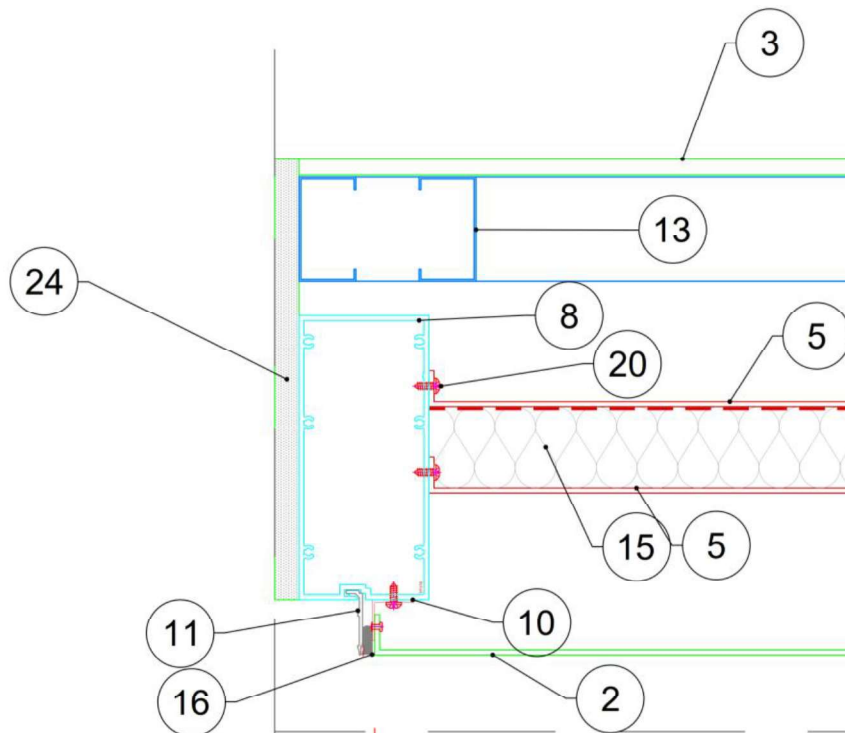


Figure 27 Horizontal cross-section of terminating module detail.

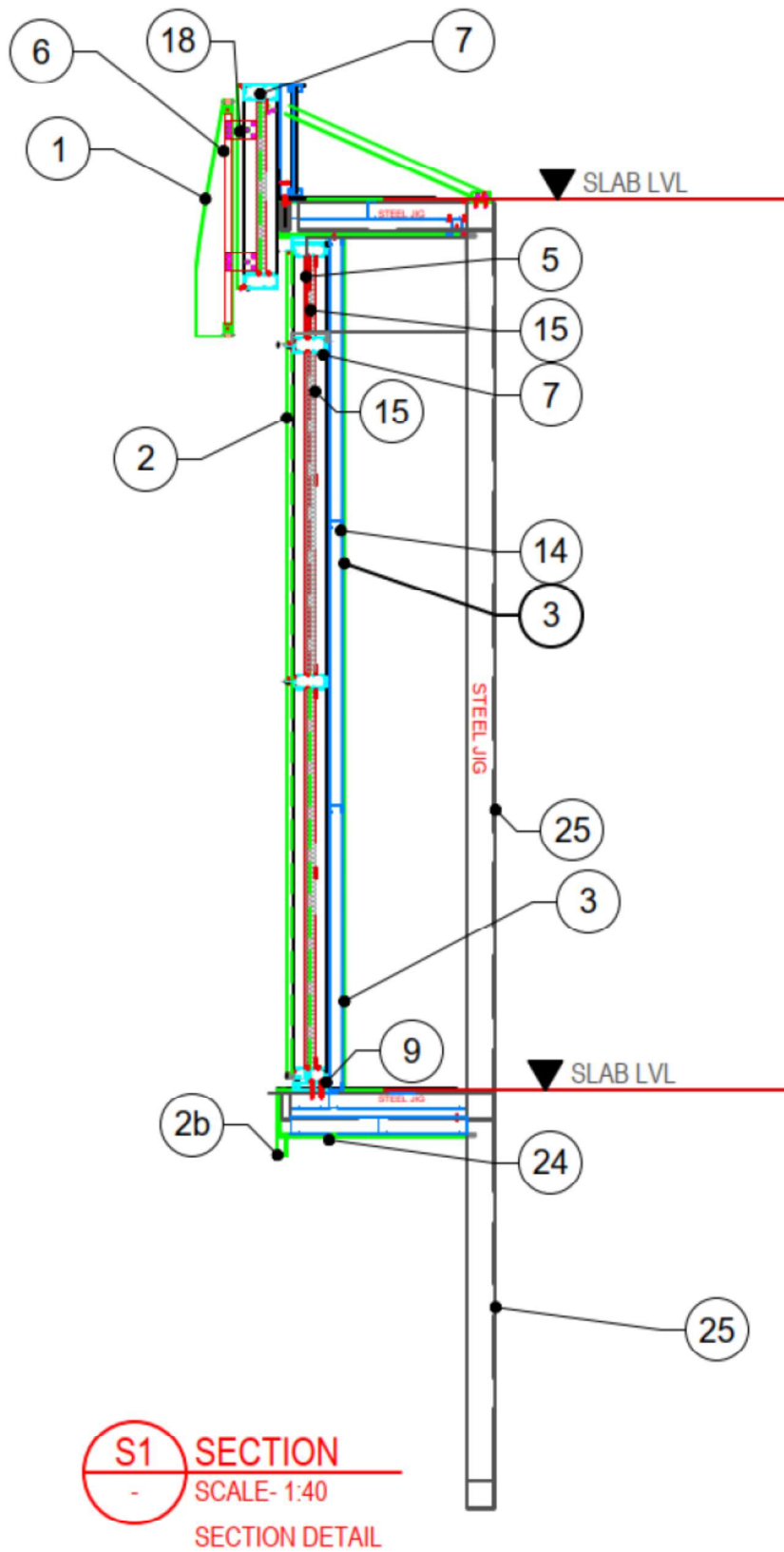


Figure 28 Vertical cross-section of the main wall – with leaders.

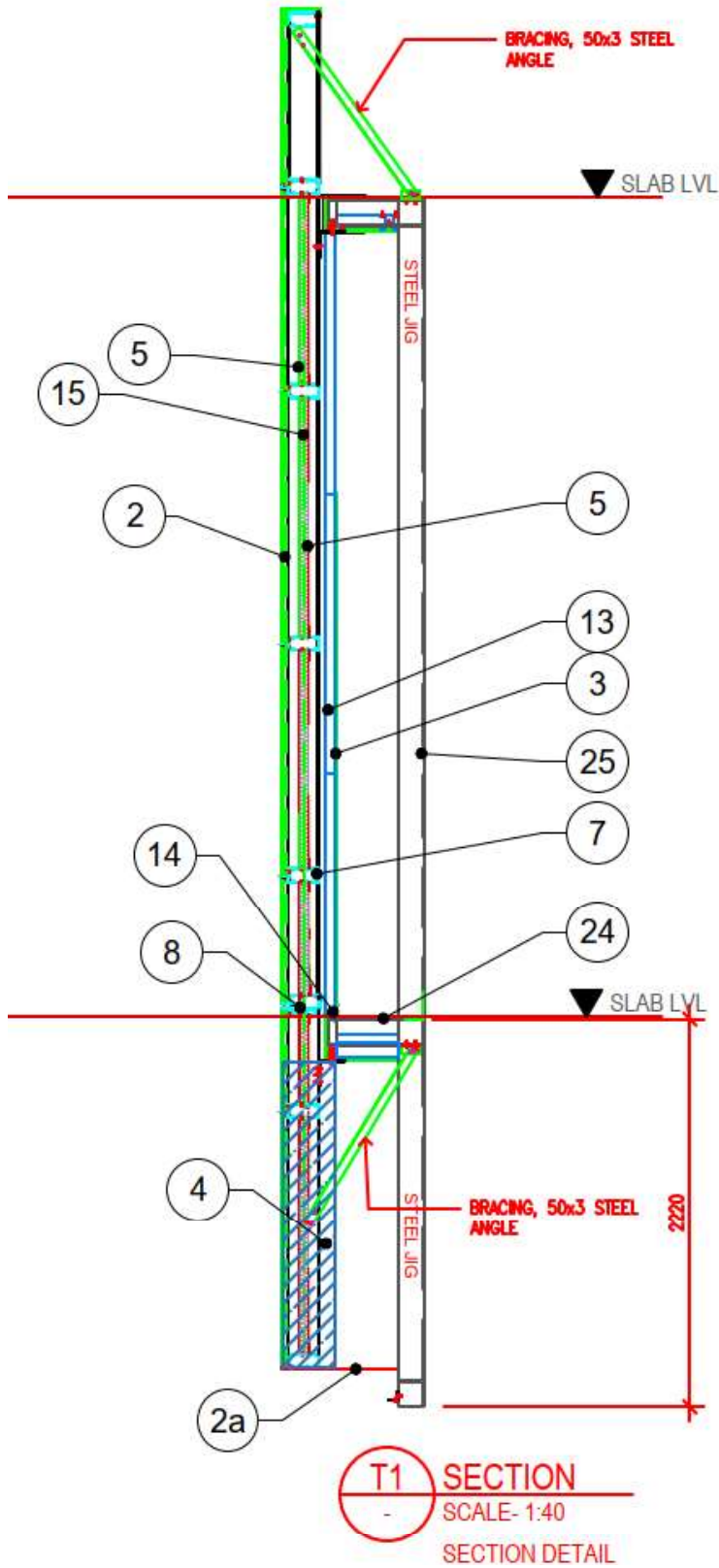


Figure 29 Vertical cross-section of the wing wall – with leaders.

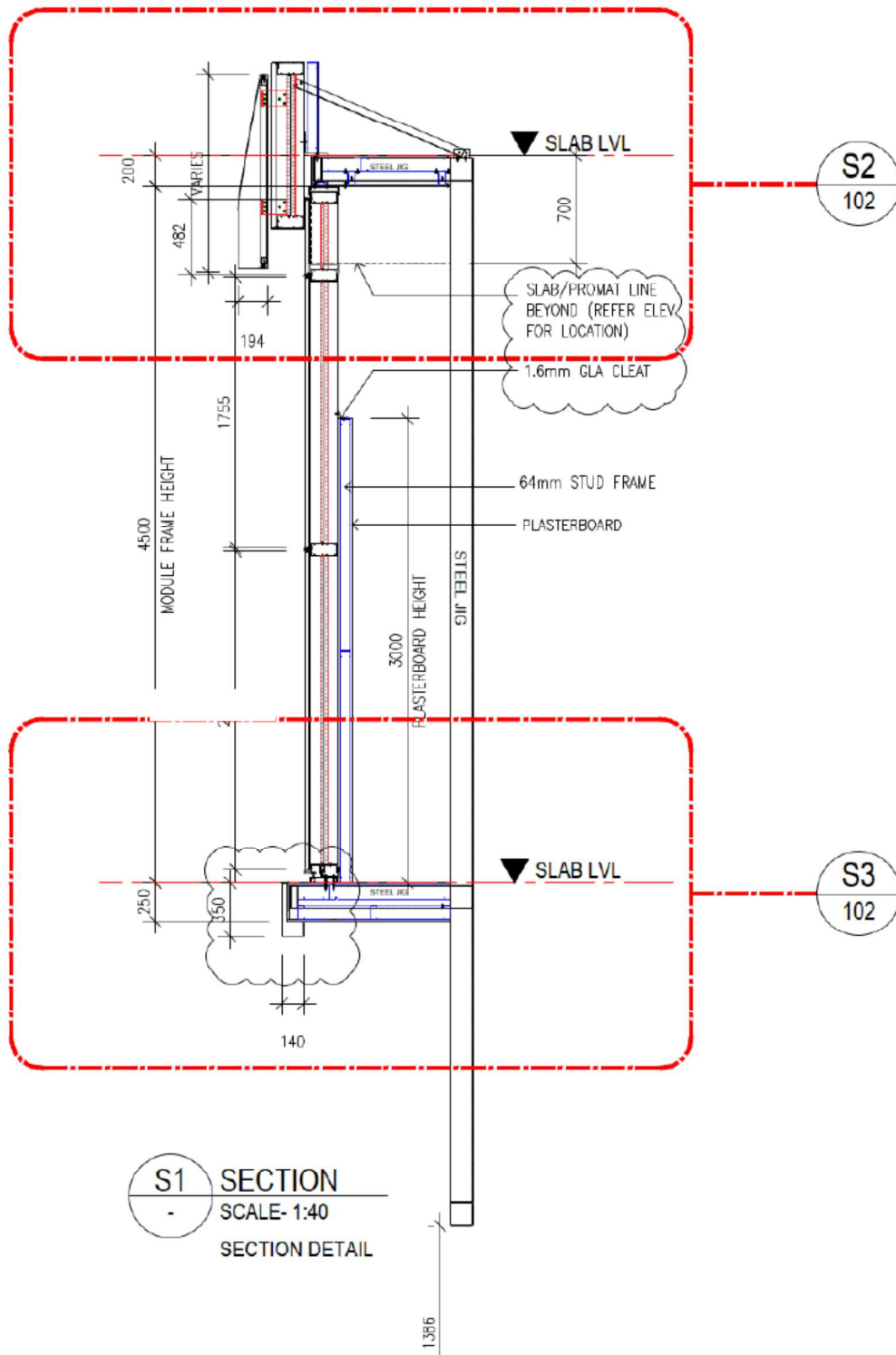


Figure 30 Vertical cross-section of the main wall – with dimensions.

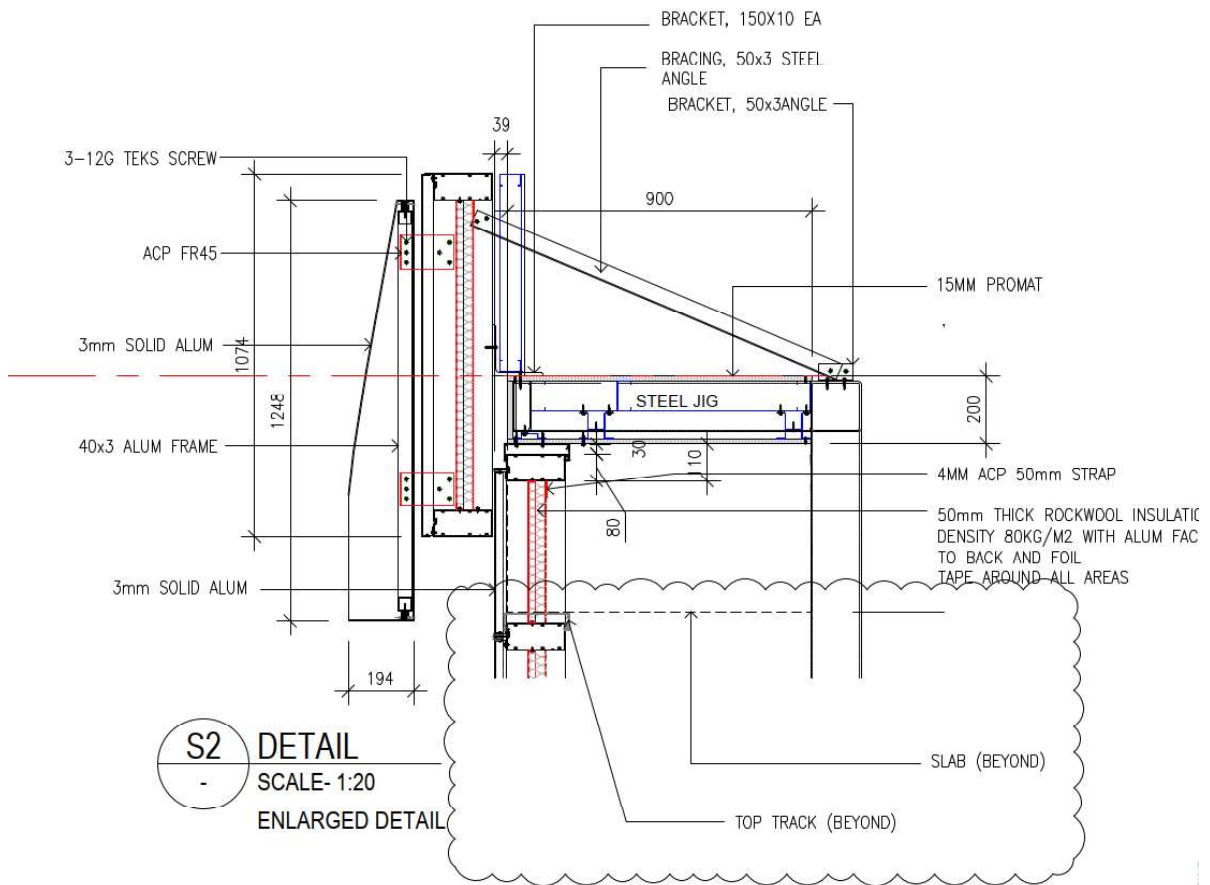


Figure 31 Vertical cross-section of the main wall – with dimensions.

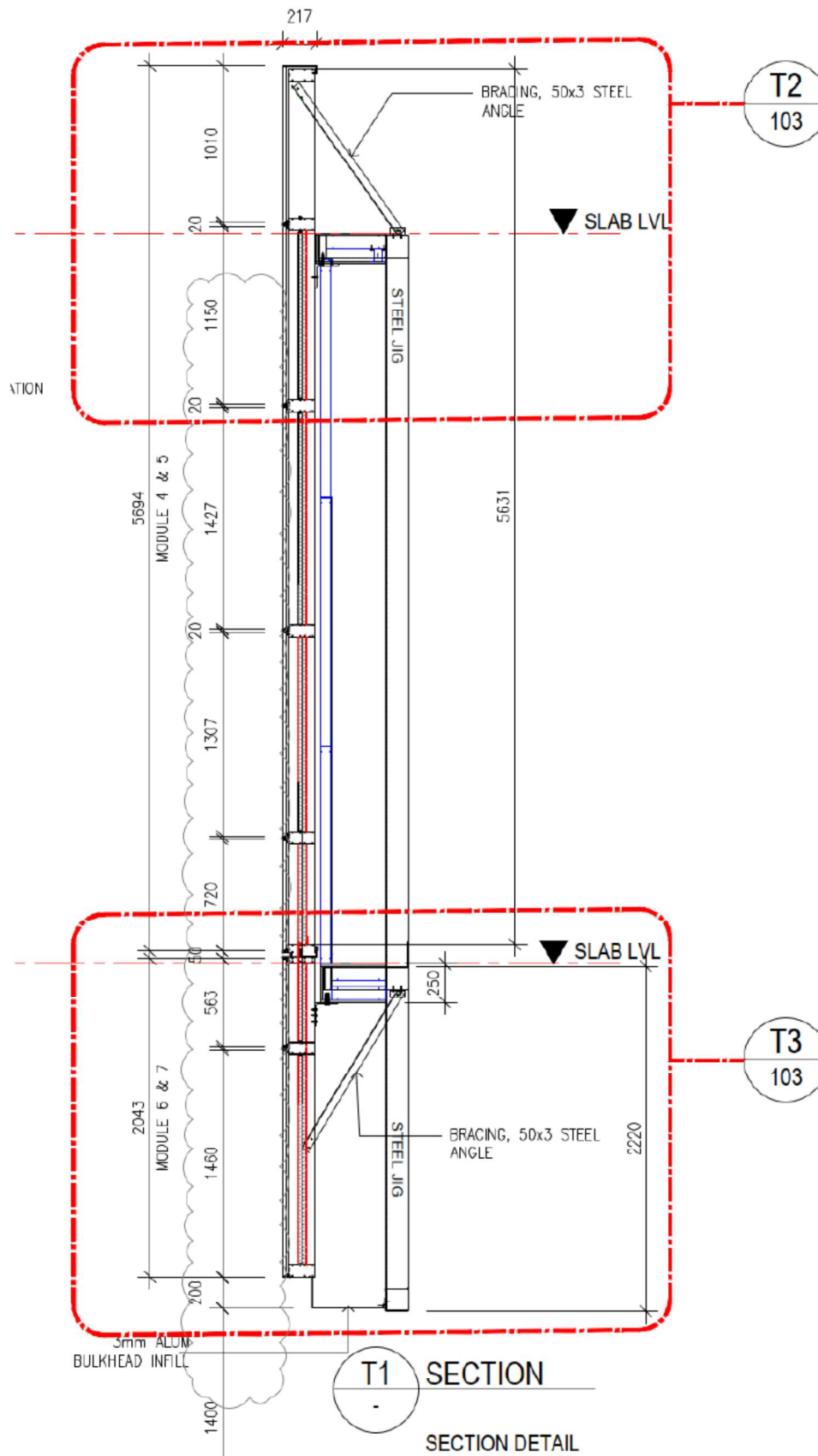


Figure 32 Vertical cross-section of the wing wall – with dimensions.

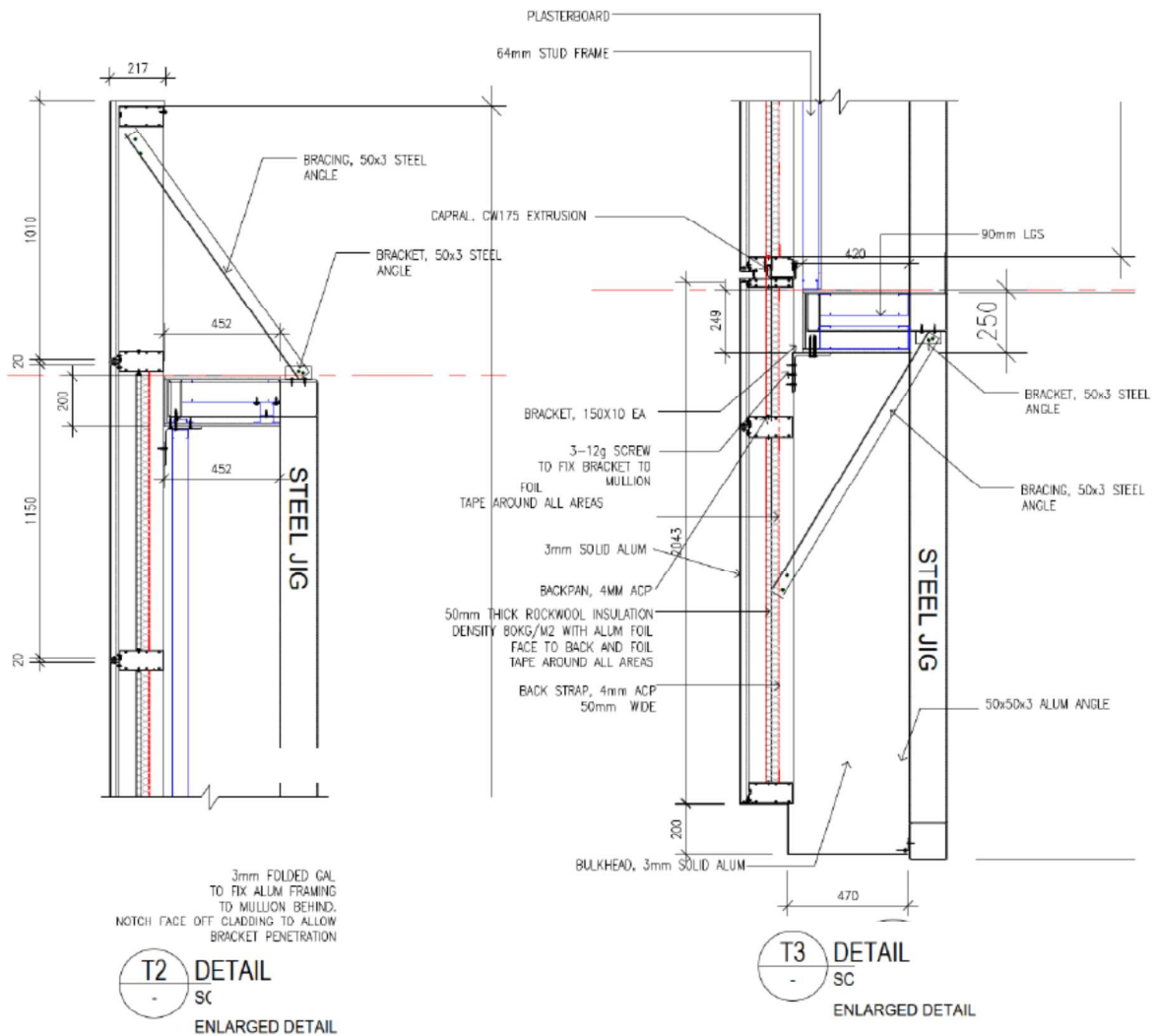


Figure 33 Vertical cross-section of the wing wall – with dimensions.

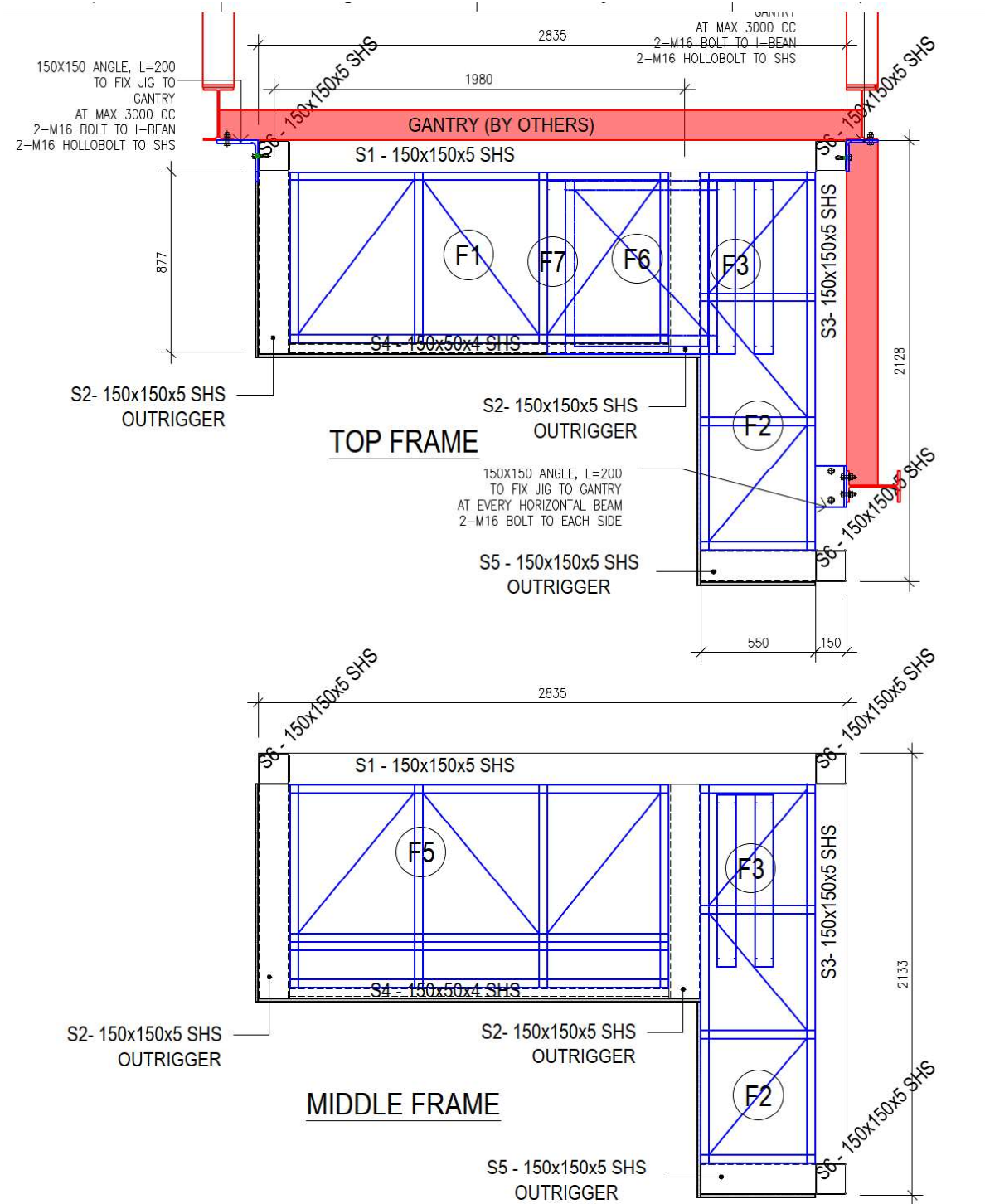


Figure 34 Drawings of the Jig.

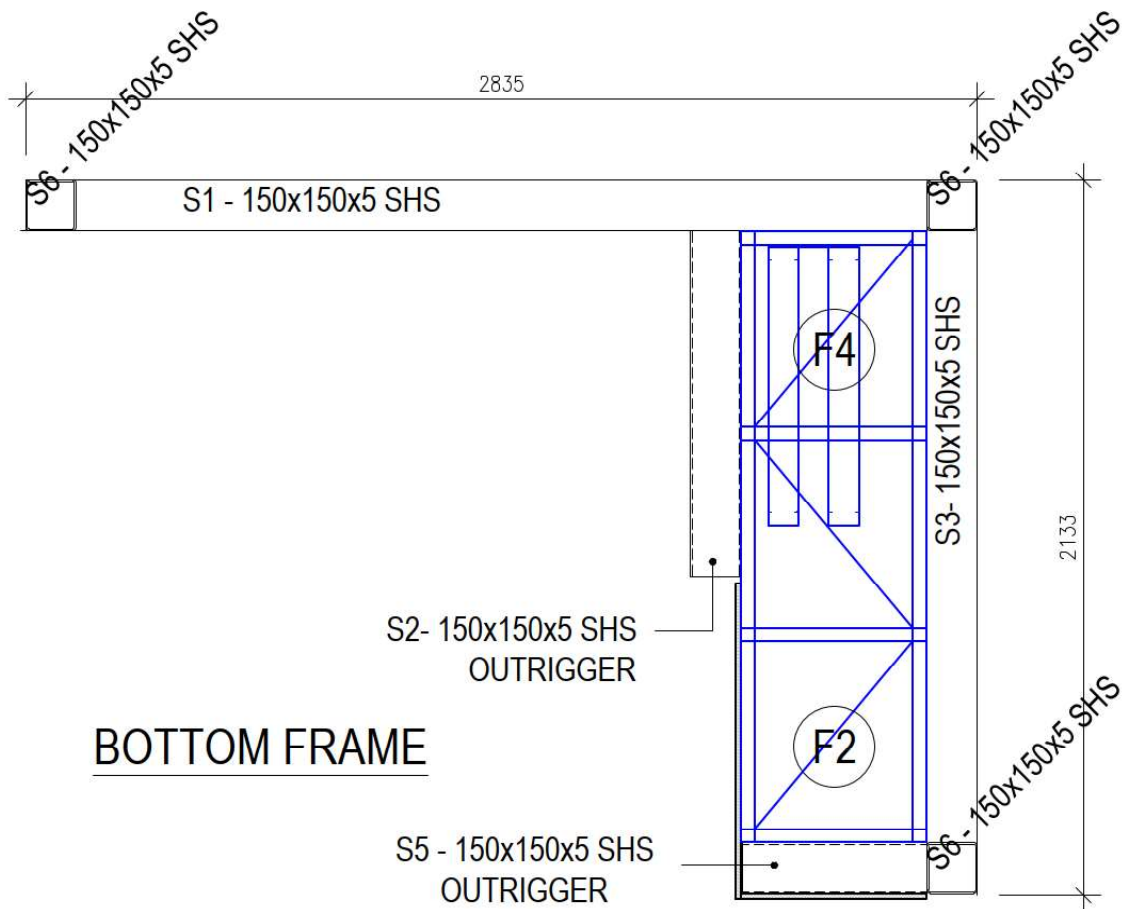


Figure 36 Drawings of the Jig.

Appendix B Test observations

B.1 Visual observation

Figure 37 shows the designations for the test specimen observations.

Table 5 shows the observations of any significant behaviour of the specimen during the test.



Figure 37 Designation for the test specimen observations

Table 5 Test observations

Time		Section	Observation
Min	Sec		
-5	00	All	Data collection started.
0	00	All	The reaction to fire test started. The burner was ignited with the output set to a heat release rate of 100 kW.
15	00	All	The burner output was set to a heat release rate of 300 kW.
15	41	6A	Smoke emitted from the underneath of module 6.
20	35	6A	The sealant on the lower edge started to melt and come out.
30	25	6A, 7A	The bottom plate had deformed.
40	00	All	The burner was turned off.
60	00	All	The reaction to fire test was ended.

Appendix C Photographs



Figure 38 The specimen before the test – exposed side



Figure 39 The specimen 50 seconds into the test with the burner at 500 kW



Figure 40 The specimen 10 minutes into the test with the burner at 100 kW



Figure 41 The specimen 15 minutes and 50 seconds into the test - 50 seconds after the burner output was increased to 300 kW.



Figure 42 The specimen 30 minutes and 51 seconds into the test – 15 minutes 51 seconds after the burner output was increased to 300 kW.



Figure 43 The specimen 39 minutes 51 seconds into the test – 24 minutes 51 seconds after the burner output was increased to 300 kW.



Figure 44 The specimen 40 minutes and 50 seconds into the test – 50 seconds after the burner was turned off.



Figure 45 The exposed face of the specimen after the test



Figure 46 The exposed face of backpan of modules 6 and 7, respectively, after sampling at the end of the test.

Appendix D Chemical Analysis Results



UNSW RESEARCH INFRASTRUCTURE

Chemical Consulting Laboratory

Mark Wainwright Analytical Centre
UNSW Sydney NSW 2052 Australia

T: +61(2) 9348 1400 | E: ccl@unsw.edu.au
W: www.analytical.unsw.edu.au/contact-us/commercial-consulting
ABN 57 195 873 179 | CRICOS Provider Code 00098G

Test Report

ANALYSIS OF CLADDING SAMPLE

For

Company: Jensen Hughes

Contact: [REDACTED]

Date: 4 April 2025

Project No: 25082

Prepared by: [REDACTED]

Approved by: [REDACTED]

COMMERCIAL-IN-CONFIDENCE

Any use of the Test Report, use of any part of it, use of the names University of New South Wales or UNSW, use of the name of any Unit of UNSW, or use of the name of the consultant in direct or indirect advertising or publicity is strictly forbidden.



Analysis of Cladding Sample

1. SAMPLES

One envelope containing one ACP core was received for analysis. The sample was identified as follows:

CCL sample coding	Client sample coding
25082-1	ACP

CCL has been asked to identify the polymer and the filler (s) in the sample by FT/IR, quantitate and identify the mineral filler in the sample and classify them in accordance with the ICA cladding scheme.

2. METHODOLOGY AND RESULTS

The aluminium metals were removed from the ACPs cladding polymers, and the flat surface of the polymer sample was abraded to remove any surface adhesive. The surface of the sample was analysed directly by FTIR. The FT-IR spectrum is presented in Figure 1.

The core of the sample was then ashed to determine its percentage mineral content (Table 1). If sufficient (>0.5 g) ash was found, it was analysed for elemental composition by X ray fluorescence spectroscopy. Results are presented in Table 2.

Table 1 Ash content of 25082-1

Sample coding	Ash content (w/w%)
25082-1	40.1

Table 2 Elemental composition of 25082-1

Element Oxide wt. %	25082-1
Na ₂ O	0.12
MgO	78.74
Al ₂ O ₃	0.38
SiO ₂	4.79
P ₂ O ₅	0.12
SO ₃	0.42
K ₂ O	0.04
CaO	7.92
TiO ₂	2.26
V ₂ O ₅	<0.01
Cr ₂ O ₃	<0.01
Mn ₃ O ₄	0.05
Fe ₂ O ₃	0.47
NiO	<0.01
CuO	<0.01
ZnO	0.02
SrO	0.01
ZrO ₂	<0.01
BaO	0.13
HfO ₂	<0.01
PbO	0.01
SnO ₂	0.01
CoO	<0.01
L.O.I.	ND

NOTE: (i) L.O.I.= loss on ignition at 1,050 °C.
(ii) ND = not determined



3. CONCLUSIONS


The cladding Sample #1 consisted of 45.7% magnesium hydroxide, 5.7% calcium carbonate, 5.3% other inert material and approximately 43.3% Polyethylene polymer.

The cladding sample #1 is classified as ICA category A.

The ICA Classification assigned is correct as per the September 2020 revision of the ICA Guidelines.

The calculation for magnesium hydroxide content assumes that all magnesium found is present as the hydroxide. The calculation for calcium carbonate content assumes that all calcium found is present as the carbonate.

The reader is reminded that we can only analyse and classify the content of samples actually presented to us. We can offer no guarantee that this composition or classification is valid for cladding as a whole, because some types of cladding can be inhomogeneous, and a sample may not be representative of the cladding as a whole. Anyone using our results should consider these sampling issues and uncertainties before they generalise the results we present to anybody of cladding as a whole.


Technical Officer
Chemical Consulting Laboratory
Mark Wainwright Analytical Centre, UNSW
4 April 2025



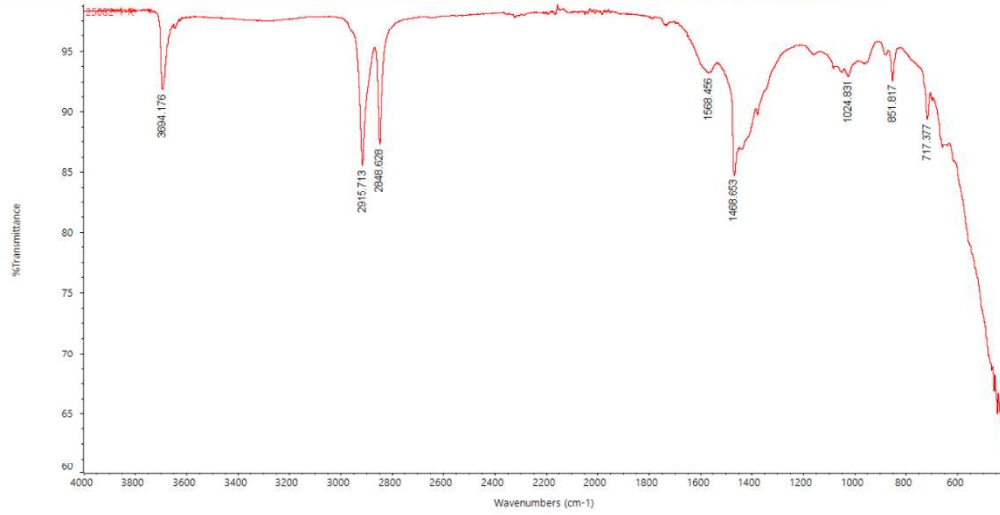


Figure 1. FT-IR spectrum of sample 1



UNSW RESEARCH INFRASTRUCTURE

Chemical Consulting Laboratory

Mark Wainwright Analytical Centre
UNSW Sydney NSW 2052 Australia

T: +61(2) 9348 1400 | E: ccl@unsw.edu.au
W: www.analytical.unsw.edu.au/contact-us/commercial-consulting
ABN 57 195 873 179 | CRICOS Provider Code 00098G

Test Report

Prepared by:

ANALYSIS OF CLADDING SAMPLES

For

Company: Warrington Fire

Contact: [REDACTED]

Date: 22 February 2024

Project No: 24021

Prepared by: [REDACTED]

Approved by: [REDACTED]

COMMERCIAL-IN-CONFIDENCE

Any use of the Test Report, use of any part of it, use of the names University of New South Wales or UNSW, use of the name of any Unit of UNSW, or use of the name of the consultant in direct or indirect advertising or publicity is strictly forbidden.



Analysis of Cladding Samples

1. SAMPLES

One envelope containing three ACP cores was received for analysis. The samples were identified as follows:

CCL sample coding	Client sample coding
24021-1	#1 - 100%
24021-2	#2 - 100%

CCL has been asked to identify the polymer and the filler (s) in the samples by FT/IR, quantitate and identify the mineral filler in the samples and classify them in accordance with the ICA cladding scheme.

2. METHODOLOGY AND RESULTS

The aluminium metals were removed from the ACPs cladding polymer, and the flat surface of the polymer sample was abraded to remove any surface adhesive. The surface of the sample was analysed directly by FTIR. The FT-IR spectra are presented in Figures 1-3.

The core of the samples was then ashed to determine their percentage mineral content (Table 1). If sufficient (>0.5 g) ash was found in the sample, it was analysed for elemental composition by X ray fluorescence spectroscopy. Results are presented in Table 2.

Table 1 Ash content of 24021-1-3

Sample coding	Ash content (w/w%)
24021-1	3.3
24021-2	3.0

3. CONCLUSIONS

The cladding sample #1 consisted of 3.3% inert material and approximately 96% polyethylene polymer.
The cladding sample #1 is classified as ICA category A.

The cladding sample #2 consisted of 3.0% inert material and approximately 97% polyethylene polymer.
The cladding sample #2 is classified as ICA category A.

The ICA Classification assigned is correct as per the September 2020 revision of the ICA Guidelines.

The reader is reminded that we can only analyse and classify the content of samples actually presented to us. We can offer no guarantee that this composition or classification is valid for cladding as a whole, because some types of cladding can be inhomogeneous, and a sample may not be representative of the cladding as a whole. Anyone using our results should consider these sampling issues and uncertainties before they generalise the results we present to anybody of cladding as a whole.


Senior Technical Officer
Chemical Consulting Laboratory
Mark Wainwright Analytical Centre, UNSW
22 February 2024



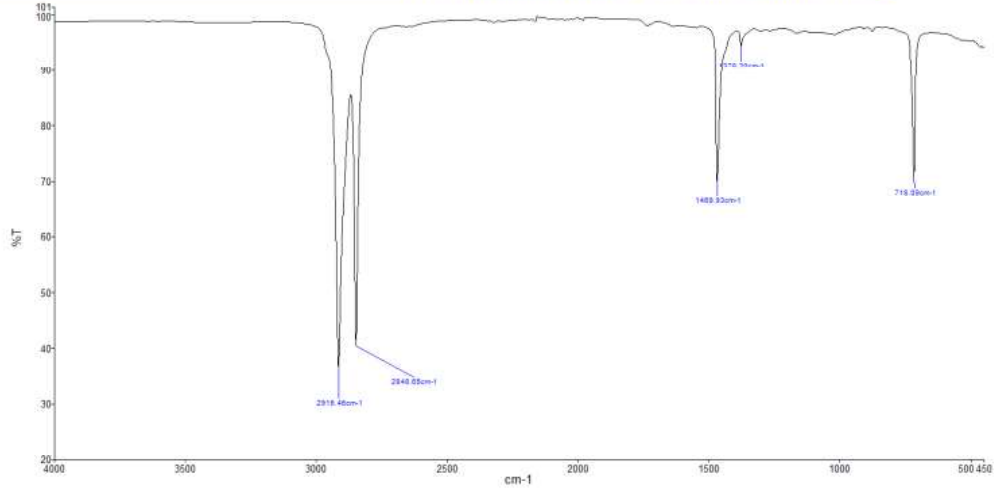


Figure 1. FT-IR spectrum of sample #1

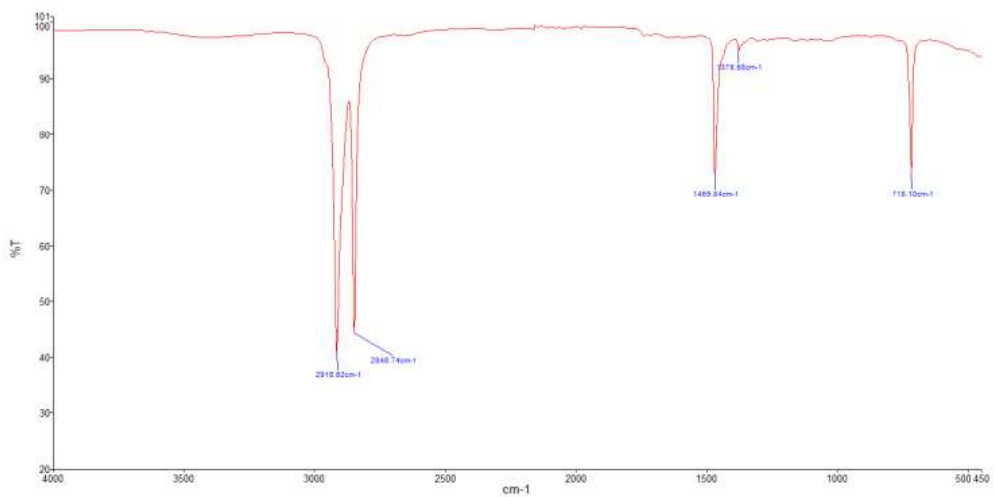


Figure 2. FT-IR spectrum of sample #2





JENSEN HUGHES

Jensen Hughes Fire Testing Pty Ltd
ABN 81 050 241 524

Perth

Suite 4.01, 256 Adelaide Terrace
Perth WA 6000
Australia
T: +61 8 9382 3844

Canberra

Unit 10, 71 Leichhardt Street
Kingston ACT 2604
Australia
T: +61 2 6260 8488

Melbourne

Level 4, 152 Elizabeth Street
Melbourne Vic 3000
Australia
T: +61 3 9767 1000

Sydney

Suite 302, Level 3, 151 Castlereagh Street
Sydney NSW 2000
Australia
T: +61 2 9411 5360

Brisbane

Suite B, Level 6, 133 Mary Street
Brisbane Qld 4000
Australia
T: +61 7 3238 1700

Melbourne – NATA accredited laboratory

409-411 Hammond Road
Dandenong South Vic 3175
Australia
T: +61 3 9767 1000

General conditions of use

The data, methodologies, calculations and results documented in this report specifically relate to the tested specimen/s and must not be used for any other purpose. This report may only be reproduced in full. Extracts or abridgements must not be published without permission from Jensen Hughes Fire Testing.

All work and services carried out by Jensen Hughes Fire Testing are subject to, and conducted in accordance with our standard terms and conditions.