

CLADDING SAFETY VICTORIA

REACTION TO FIRE TEST REPORT



Test standard: Ad-hoc test based on ISO 13785-1:2002

Test sponsor: Cladding Safety Victoria

Product: Aluminium composite panel curtain wall system nominated as being representative of [REDACTED]

[REDACTED]-Test 1

Job number: RTF121570

Revision: RR1.0

Test date: 13 June 2025

Accredited for compliance with ISO/IEC 17025:2017 – Testing

JENSEN HUGHES

Quality management

Revision	Date	Revision description		
RR1.0	8 September 2025	Initial issue.		
		Prepared	Reviewed	Authorised
		██████████	██████████	██████████

Jensen Hughes Fire Testing Pty Ltd
ABN 81 050 241 524
Formerly Warringtonfire Australia Pty Ltd¹

¹ Warringtonfire Australia Pty Ltd was acquired by Jensen Hughes in December 2023. Jensen Hughes Fire Testing Pty Ltd is not affiliated, associated, authorised, or endorsed by Warringtonfire Australia Pty Ltd, Warringtonfire Testing and Certification Limited or its "Warringtonfire" or "Certifire" brands.

Table of contents

Quality management	2
1.0 Introduction	4
2.0 Test specimen.....	5
2.1 Schedule of components	5
2.2 Installation details	12
3.0 Test procedure.....	13
4.0 Instrumentation locations	14
5.0 Test measurements and results	16
6.0 Application of test results	17
6.1 Test limitations	17
6.2 Variations from the tested specimen.....	17
6.3 Uncertainty of measurements	17
Appendix A Drawings of test assembly.....	18
Appendix B Test observations	27
B.1 Visual observation	27
Appendix C Test data	29
C.1 Specimen temperatures	29
Appendix D Photographs.....	37
Appendix E Chemical analysis results	55

1.0 Introduction

This report documents the findings of the first of three ad-hoc reaction to fire tests conducted on an aluminium composite panel (ACP) curtain wall system nominated as being representative of [REDACTED]. The test was performed on 13 June 2025 in general accordance with ISO 13785-1:2002.

Jensen Hughes performed the test at the request of the test sponsor listed in Table 1.

Table 1 Test sponsor details

Test sponsor	Address
Cladding Safety Victoria (CSV)	120 A'Beckett Street Melbourne VIC 3000 Australia

2.0 Test specimen

2.1 Schedule of components

Table 2 describes the test specimen and lists the schedule of components. These were provided by the test sponsor and surveyed by Jensen Hughes.

All measurements were done by Jensen Hughes – unless indicated otherwise.

Detailed drawings of the test specimen are provided in Appendix A.

Table 2 Schedule of components

Item	Description		
Cladding			
1.	Item name	3D architectural fixture cladding	
	Product	[REDACTED]	
	Location	Used to form the profiled fixture (3D Shape) on the wing wall on level 1 and level 2 which had overall dimensions of 1248 mm high × 1120 mm wide × 250 mm deep. The shapes consisted of three weep holes at the bottom. A section of the fixture with an overall dimension of 615 mm high × 1120 mm wide × 194 mm deep was fixed on the ground level of the wing wall. Refer to Figure 5, Figure 6 and Figure 9 for further details.	
	Supplier	[REDACTED]	
	Note on supply of panel	On behalf of CSV, Jensen Hughes acquired the ACPs with 45 % polyethylene core.	
	Material	The product was nominated as panels consisting of two layers of aluminium sheets sandwiching a layer (core) with 45% polyethylene (PE) and inorganic filler. Analysis conducted by the analytical centre of UNSW showed that the core consisted of polyethylene-vinyl acetate (PEVA) - found to be 43.9 % w/w - whilst the remainder of the material was found to be 45.3 % magnesium hydroxide, 6.1 % calcium carbonate and 4.8 % other inert material. Refer to 25082-1 in Appendix E for details.	
		Skin finishes	Front skin – Dark brown oak pattern Back skin – Matte white
		Core colour	Light grey
	Size	Total panel thickness	4.0 mm
		Core thickness	2.9 mm
Skin thickness (both)		0.5 mm	
Date of manufacture	12/05/2023		
2.	Item name	Solid aluminium cladding – Main and return wall cladding	
	Product name	[REDACTED]	
	Description	3 mm solid aluminium cassette fix system	
	Manufacturer/supplier	[REDACTED]	
	Colour	Reflective grey	
	Size	Various sizes. Refer to Figure 3 and Figure 7 for full details.	
	Installation	The solid aluminium cladding was made into a cassette – 25 mm total depth. The cassettes were secured to the aluminium framing (items 10 and 11) via equal angles (item 13) fixed through the 25 mm lip of the aluminium cassette using 10g screws (item 30) at 300 mm centres.	
3.	Item name	16 mm fire rated plasterboard	
	Product	[REDACTED]	
	Manufacturer/supplier	[REDACTED]	

Item	Description	
	Size	1200 mm wide × 16 mm thick cut to length
	Batch date	9314450006378 07/03/2025
	Linear density	12.9 kg/m ² (nominated)
	Usage	To line the main wall behind the balcony. To line the wing wall behind the MgO board (item 5) section.
4.	Item name	10 mm standard plasterboard
	Product	[REDACTED]
	Manufacturer/supplier	[REDACTED]
	Size	1200 mm wide × 10 mm thick cut to length
	Batch date	Unknown
	Linear density	5.7 kg/m ³ (nominated)
	Usage	Used to line the section behind the ACP cladding (item 7) - on either side of the rockwool insulation of the wing wall.
5.	Item name	10 mm Magnesium Oxide (MgO) board
	Product	[REDACTED]
	Manufacturer/supplier	[REDACTED]
	Size	1200 mm wide × 10 mm thick cut to length
	Batch date	Unknown
	Density	1500 kg/m ³ (nominated)
	Usage	To line the exposed side of the wingwall section between the balustrade and the main wall.
6.	Item name	Sarking
	Product	[REDACTED]
	Manufacturer/supplier	[REDACTED]
	Thickness	0.09 mm
	Batch date	Unknown
	Usage	Installed between the 16 mm fire rated plasterboard (item 3) and the furring channels (item 21) and fixed with screws (item 29) through furring channels and plasterboard to the stud behind.
Back pan		
7.	Item name	Aluminium composite panel (ACP)
	Product	[REDACTED]
	Location	Used as a back pan behind the solid aluminium cladding (item 2).
	Supplier	[REDACTED]
	Note on Supply of Panel	On behalf of CSV, Jensen Hughes (formerly Warringtonfire) acquired the ACPs with 100% polyethylene core. To the best of Jensen Hughes' knowledge this is a custom production which the supplier doesn't normally supply. The panels were provided on the basis that this was for research purposes and not any purpose other than fire testing.
	Material	The product was nominated as panels consisting of two layers of aluminium sheets sandwiching a layer (core) with 100 % polyethylene (PE). Analysis conducted by the analytical centre of UNSW showed that the core consisted of polyethylene (PE) - found to be 96% w/w - whilst the remainder of the material was found to be 3.3% inert material. Refer to sample 24021-1 in Appendix E for details.
	Skin finishes	Front skin – Gloss white Back skin – Light grey (facing the exposed side)
	Core colour	Black
	Size	Total panel thickness – 4.0 mm Skin thickness – 0.5 mm (both) Core thickness – 3.0 mm thick
	Date of manufacture	2023/12/05

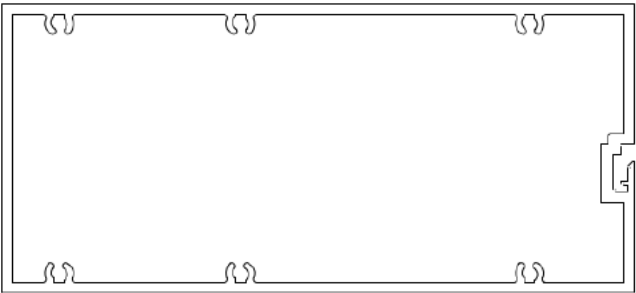
Item	Description		
	Areal density	5.6 kg/m ²	
7a.	Item name	Aluminium composite panel (ACP) strap	
	Product	[REDACTED]	
	Description	The Aluminium composite panel (ACP) straps were cut from ACP (item 7)	
	Location	Used as a 50 mm wide strap to hold the insulation (item 22) in place behind the ACP panels (item 7) installed at 300 mm centres.	
	Size	50 mm wide × 4 mm thick × cut to length.	
Glazing			
8.	Item name	Heat strengthened double glazed glass	
	Description	2 layers of 10 mm thick heat strengthened glass with 1.9 mm Polyvinyl Butyral (PVB) inter layer.	
	Manufacturer/supplier	[REDACTED]	
	Material	Clear float toughened C-LAM with polyvinyl butyral interlayer.	
	Size	Ground level Level 1 and 2	1042 mm high × 990 mm wide × 21.52 mm overall thick 1682 mm high × 990 mm wide × 21.52 mm overall thick
	Usage	Installed in the balustrade (item 12) frame to form the glazing element of the balcony.	
Framing			
9.	Item name	SHS Framing	
	Manufacturer/supplier	[REDACTED]	
	Material	Aluminium	
	Size	40 mm × 40 mm × 3 mm thick	
	Usage	Used as a framing for the 3D architectural module.	
10.	Item name	[REDACTED] Terminating pieces and internal	
	Component	[REDACTED]	
	Material	Extruded aluminium	
	Size	80 mm wide × 175 mm deep × 3 mm thick	
			
	Manufacturer/Supplier	[REDACTED]	
11.	Item name	[REDACTED]	
	Components	[REDACTED]	
	Material	Extruded aluminium	
	Size	116 mm high × 180 mm deep × 2.5 mm to 3 mm thick	

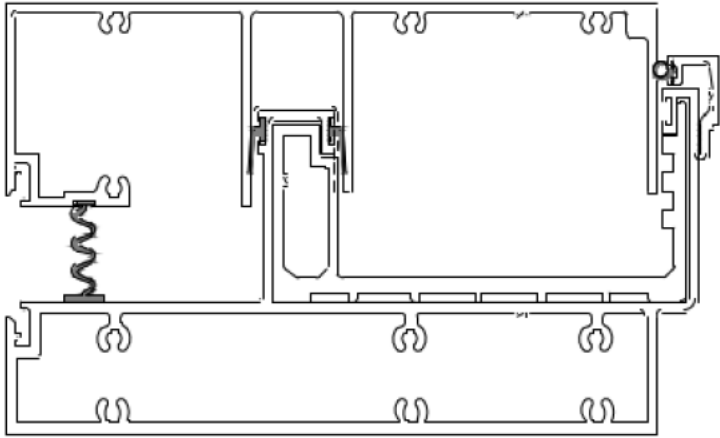
Item	Description		
			
	Manufacturer/Supplier	██████████	
12.	Item name	Balustrade glazing frame	
	Components	██████████	
	Material	Extruded aluminium	
	Size	Ground level	150 mm deep × 1135 mm high × 1080 mm wide
		Level 1 and 2	150 mm deep × 1775 mm high × 1080 mm wide
	Manufacturer/Supplier	██████████	
13.	Item name	Aluminium equal angle	
	Material	Aluminium	
	Size	25 mm × 25 mm × 1 mm thick	
	Usage	Fixed to the front face of the curtainwall transom/mullions (item 10) and gutter sill transoms (item 11) to allow fixing of the aluminium panels (item 2).	
	Manufacturer/Supplier	██████████	
14.	Item name	Framing equal angle - cleat	
	Manufacturer/supplier	██████████	
	Size	40 mm × 40 mm × 3 mm	
	Usage	Used to fix aluminium framing members together. Used in conjunction with hex-head screws (item 29)	
15.	Item name	Aluminium equal angle	
	Material	Aluminium	
	Size	50 mm deep × 50 mm high × 100 mm long × 3 mm thick	
	Usage	A combination of two equal angles were fixed to the front bottom face of the glazing frame (item 12) to allow fixing of the sunshade (item 34) using 12g × 45 mm Hex Head screws (item 31). The equal angles were fixed 60 mm from both edges of the balustrade.	
	Manufacturer/Supplier	██████████	
16.	Item name	Steel angle bracket	
	Material	Steel	
	Size	200 mm deep × 100 mm high × 50 mm wide × 10 mm thick	
	Usage	Two steel angle brackets were fixed to the front edge of the balcony floor with 12g × 45 mm Hex Head screws (item 31) to allow fixing of the balustrade glazing frame (item 12).	
	Supplier	██████████	
17.	Item name	Balcony framing – studs	
	Description	██████████	
	Material	Galvanised steel	

Item	Description	
	Size	92 mm high × 4800 mm long × 36 mm wide × 1.5 mm thick
	Usage	Used for the steel framed balcony floor.
	Manufacturer/supplier	██████████
18.	Item name	Wall framing – studs
	Description	██████████
	Material	Galvanised steel
	Size	64 mm deep × 4800 mm long × 36 mm wide × 1.5 mm thick
	Usage	Used for the steel framed main wall and balcony section of the wing wall.
	Batch date	Unknown
	Manufacturer/supplier	██████████
19.	Item name	Wall framing – nogging track
	Description	██
	Material	Galvanised steel
	Size	67 mm × 20 mm × 0.7 mm BMT
	Usage	Used for the steel framed plasterboard wall.
	Batch date	Unknown
	Manufacturer/supplier	██████████
20.	Item name	Wall framing – head track
	Material	Galvanised steel
	Size	67 mm × 20 mm × 0.7 mm BMT
	Usage	Used for the steel framed plasterboard wall.
	Manufacturer/supplier	██████████
21.	Item name	Furring channel
	Material	Galvanised steel
	Size	16 mm high × 48 mm wide × 1.5 mm thick
	Usage	Used between the MgO board and sarking/plasterboard fixed to 16 mm fire rated plasterboard (item 3) with Hex Head screws (item 29). Used to fix the 3D architectural module to the curtainwall mullion with aluminium panel screws (item 31).
	Manufacturer/supplier	██████████
Insulation		
22.	Item name	Foil faced 50 mm thick mineral wool insulation
	Product Name	██
	Description	Foil face 50 mm thick mineral wool core comprised of stone wool insulation with reinforced aluminium foil facing on one face of the stone wool.
	Mass per unit area	80 kg/m ² (nominated)
	Usage	Used as an insulation within the wingwall cavity. Used as a smoke seal
	Manufacturer/supplier	██████████
Sealant/Adhesive		
23.	Item name	Weathering sealant
	Product name	██
	Material	Silicone sealant
	Batch	SC2107782-0125 SL2
	Manufacturer/supplier	██████████
	Usage	Applied at ACP edges and over the screw locations. Applied at the vertical joint between the ACP section and the MgO board section of the wing wall. Applied around the glazing within the balustrade frame.
24.	Item name	Fire rated sealant
	Product name	██

Item	Description	
	Material	Acrylic sealant
	Batch	0002560102 2E5 A0963
	Manufacturer/supplier	██████████
	Usage	Applied at plasterboard, MgO board and Promat board joints.
Fixings		
25.	Item name	Steel plate screws
	Manufacturer/supplier	██████████
	Size	10g × 50 mm countersunk head with EP+ electro polymer corrosion resistant coating.
	Usage	Used to fix steel sheet (item 35) to the bottom side of ground level curtain wall module.
26.	Item name	Transom screws
	Manufacturer/supplier	██████████
	Description	10g × 50 mm long wafer head self-tapping screws – Galvanised zinc alloy
	Usage	Fixing transoms to transoms (item 11)
27.	Item name	Aluminium panel screws
	Manufacturer/supplier	██████████
	Description	12g × 16 mm long wafer head self-tapping screws – Galvanised zinc alloy
	Usage	Used to fix the aluminium panels (item 2) to the equal angles (item 13). Used to fix the back pan (item 7) to the aluminium framing (items 10 and 11).
28.	Item name	Plasterboard screws
	Description	6g × 25 mm long bugle head self-drilling screws
	Usage	Used to fix the plasterboards (items 3 and 4) to steel frame (item 18).
29.	Item name	Hex head screw
	Manufacturer/supplier	██████████
	Description	12g × 20 mm long hex head self-tapping screws – Galvanised zinc alloy
	Usage	Used to fix the cleats (item 14) to the aluminium framing (items 10 and 11).
30.	Item name	Framing screws
	Manufacturer/supplier	██████████
	Description	10g × 16 mm long wafer head self-drilling screw
	Usage	Used to fix the wall framing members (items 18 and 19) together
31.	Item name	Aluminium panel screws
	Manufacturer/supplier	██████████
	Description	12g × 45 mm long hex head stainless steel
	Usage	Used to fix the sunshade (item 34) to the balustrade.
Fire rated board		
32.	Item name	15 mm thick fibre reinforced mineral board
	Product name	██████████
	Size	790 mm wide × 1220 mm high × 15 mm thick
	Density	840 kg/m ³
	Manufacturer/supplier	██████████
Balcony		
33.	Item name	Balcony floor
	Location	The balcony floor was located at Level 1 and Level 2 of the façade. The floor of Level 1 balcony was located 3100 mm above ground and Level 2 balcony was located 6200 mm above the ground.
	Description	The balcony frame was constructed with steel studs (item 17) and lined with 15 mm thick fibre reinforced mineral board (item 32).
	Size	Overall, 1595 mm wide × 1346 mm deep × 315 mm high
Horizontal sunshade		

Item	Description	
34.	Item name	Sunshade
	Location	The sunshade was fixed to the bottom of the glass balustrade frame.
	Material	Aluminium
	Size	Overall, 1080 mm wide × 250 mm deep × 50 mm high
Other		
35.	Item name	Steel sheet
	Material	Galvanised steel
	Size	100 mm deep × 50 mm high × 0.55 BMT
	Usage	Used as a smoke seal.
36.	Item name	Steel plate
	Location	Used to fix the 3D architectural module to the mullion.
	Material	Galvanised steel
	Size	280 mm long × 100 mm high × 5 mm thick
37.	Item name	Backing strip
	Location	The backing strip was fixed on the stud to hold the stone wool insulation behind the MgO board (item 5) section of the wing wall.
	Material	Galvanised steel
	Size	50 mm wide × 0.55 MBT cut to length
	Manufacturer/supplier	██████████
Test Rig and Jig		
38.	Item name	Steel Jig
	Size	The steel Jig was 7335 mm high × 1895 mm wide for the main wall and 7335 mm high × 3170 mm wide for the wing wall
	Description	The jig consisted of: SHS units as a main support Two simulated concrete slab floor levels constructed mainly of steel framing and 15 mm thick mineral board (item 32).
39.	Item name	Steel substrate
	Size	The steel substrate was 9300 mm high × 3245 mm wide for the main wall and 9300 mm high × 2000 mm wide for the wing wall
	Description	The substrate consisted of structural steel sections and square hollow sections (SHS).
Installation method		
Specimen overall size	7335 mm tall × 1294 mm wide main wall and 3118 mm wide for the wing wall	
Main wall size	7335 mm high × 1294 mm wide × 300 mm deep	
Return wall size	7335 mm high × 3118 mm wide × 209 mm deep	
Profiled head fixture size	1248 mm high × 1120 mm wide × 250 mm deep	

2.2 Installation details

Table 3 lists the installation details for the test specimen.

Table 3 Installation details

Item	Detail
Steel jig, false slabs modules, and plasterboard lined steel stud wall were constructed offsite. These were installed onto the test rig onsite.	
Arrival of specimen onsite	4 June 2025
Start of installation of modules onto steel jig	5 June 2025
Installation of steel jig onto steel rig	11 June 2025
Completion date for construction of the test specimen on test site	12 June 2025
External wall system constructed by	Representatives of the test sponsor
Symmetry	<p>Asymmetrical: due to the exposed face of the façade wing wall was clad with a solid aluminium panel and the unexposed side lined with standard plasterboard.</p> <p>The façade main was consisted of three levels of balustrades and balconies on the exposed side and the unexposed side was lined with fire rated plasterboard.</p> <p>It was confirmed that the system was exposed from the side that would normally face the outside of the building.</p>

3.0 Test procedure

Table 4 details the test procedure for this reaction to fire test.

Table 4 Test procedure

Item	Detail
Statement of compliance	<p>The ad-hoc test was based on the general principles outlined in ISO13785-1:2002 and was performed to determine the reaction to fire performance of an external wall cladding when exposed to heat from a simulated external fire with flames impinging directly upon a façade. The test utilised a burner outlined in ISO 13785-1:2002. There were other variations such as specimen size, instrumentation types and locations that varied from ISO 13785-1:2002.</p> <p>The specimen was constructed in a manner representative of the in situ external curtain wall detail being evaluated for the building located on [REDACTED]</p>
Sampling / specimen selection	<p>The laboratory was not involved in sampling or selecting the test specimen for the reaction to fire test.</p> <p>The results obtained during the test only apply to the test samples as received and tested by Jensen Hughes.</p>
Test duration	60 minutes
Ambient environment temperature	15 °C
Instrumentation and equipment	<ul style="list-style-type: none"> Mineral insulated metal sheathed (MIMS) Type K thermocouples with an overall diameter of 1.5 mm with the measuring junction insulated were used to measure temperatures inside and outside of the specimen. Backpan thermocouples were placed in contact with the backpan with mechanical fixing to the specimen aluminium framing at least one at one point and taped (aluminium foil) to the backpan at least 25 mm from the tip. Backpan thermocouples were inherently covered by the foil faced mineral wool insulation. Cavity thermocouples were placed mid-depth of the cavity between the plasterboard and mineral wool insulation. Cavity thermocouples were also placed mid height, mid width and mid depth of the cavity between the 3D architectural module and the cladding on level 1 and level 2. External thermocouples were placed central to the recess of modules. External thermocouples were also placed central to the top edged of the modules. External thermocouples were also placed 50 mm below the front edge of the balcony and top of the sunshade. External thermocouples were placed mid width and mid height of the 3D architectural modules. All external thermocouples were 50 mm from the exposed face cladding. Heat flux gauge was placed behind the second and third balcony glazing mid height and mid width of the glass – height measured from the balcony floor – and 10 mm from the rear face of the glazing. Refer to Figure 1 and Figure 2 for further details on positioning. The fire source was a propane (95% purity) gas burner 1.2 m long × 0.1 m deep × 0.15 m tall. The burner was placed on the floor parallel in flush with the wing wall between the glass balustrade and the rear wall specimen and in contact with the exposed face of the specimen.
Test exposure	<ul style="list-style-type: none"> Five minutes of baseline data was collected prior to burner ignition. The temperature and heat flux data were collected at 5 s intervals. The heat output from the burner was maintained at 100 kW for the first 15 minutes and then changed to 300 kW for another 25 minutes of the test. The burner was then turned off and data measured for a further 20 minutes.
Test number	Test 1 of a series of 3 tests.

4.0 Instrumentation locations

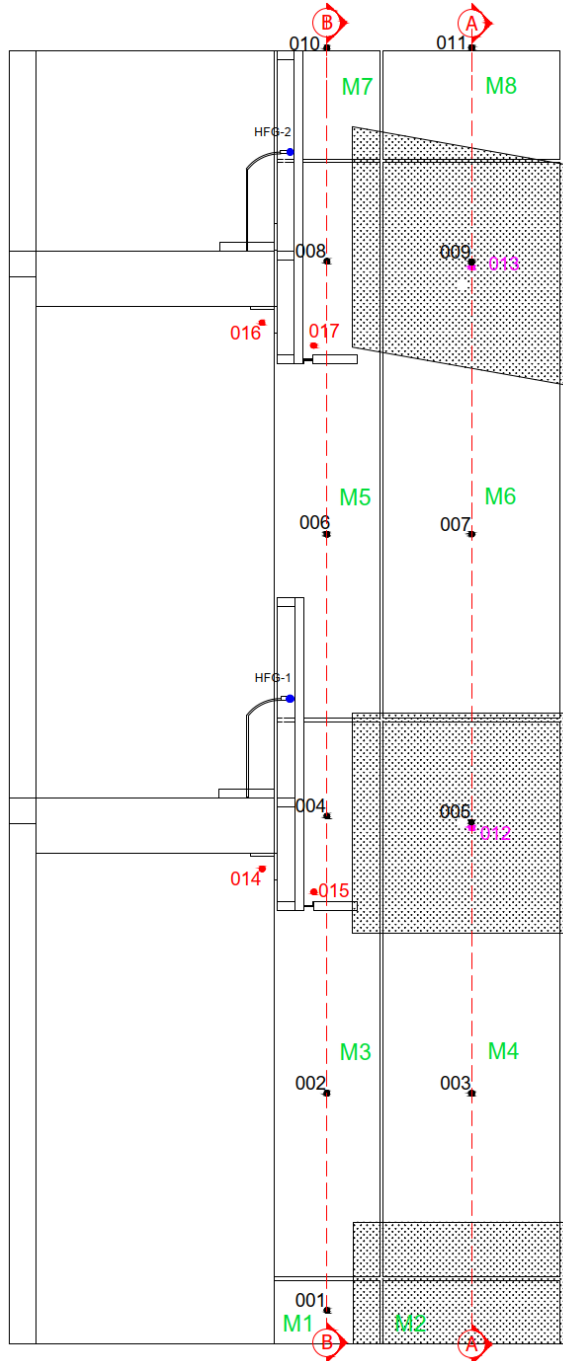

Figure 1 Instrumentation locations - external thermocouples and heat flux gauges

- Note
- Black dot represents surface thermocouple 50 mm from the surface.
 - Pink dot represents cavity thermocouple between 3D architectural module and back pan.
 - Red dot represents surface thermocouples at the balcony adjoining surfaces.
 - Blue dot represents heat flux gauges.
- M1 to M8 represents modules 1 to 8

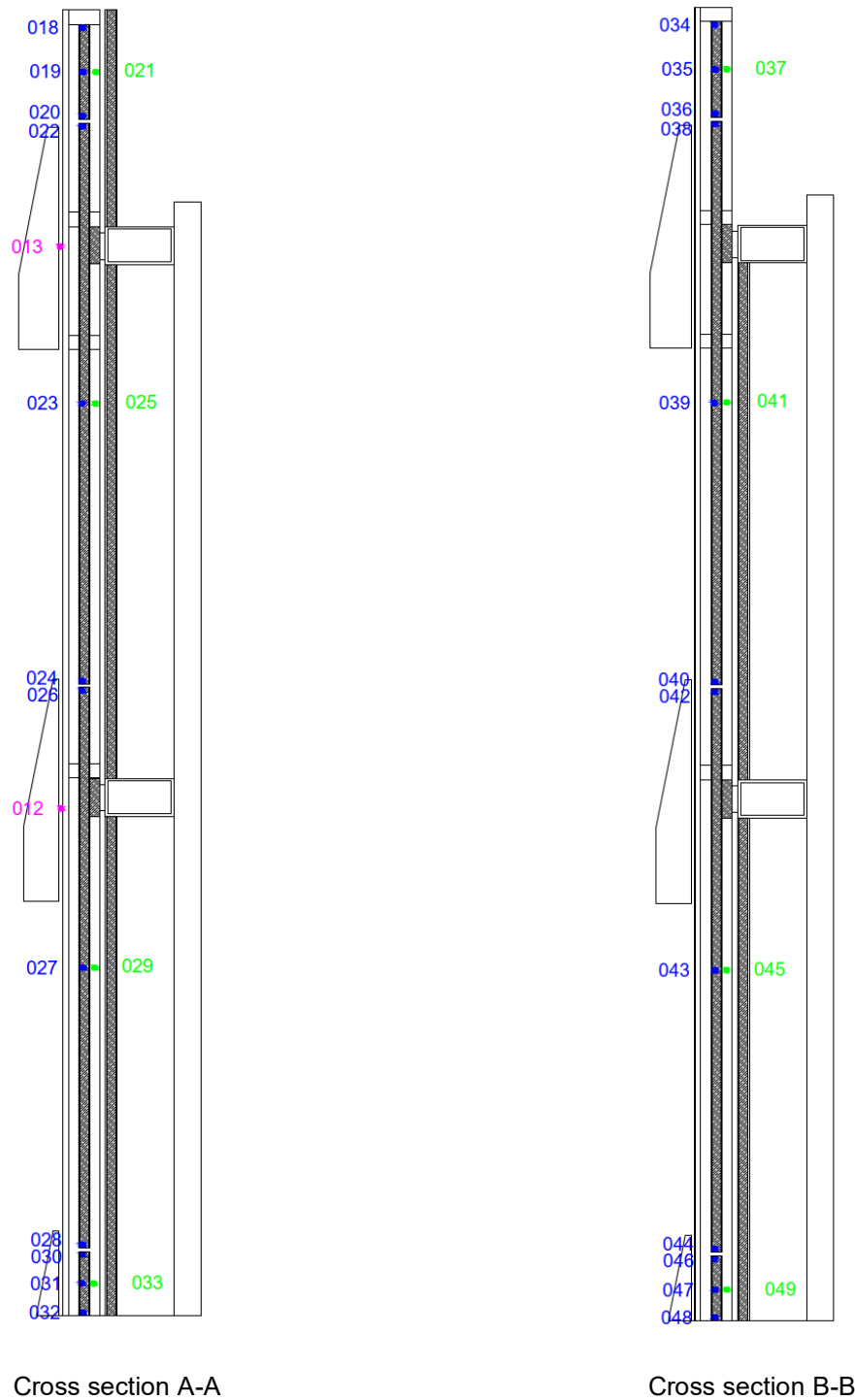

Figure 2 Instrumentation locations – Internal and cavity thermocouples - cross section A-A

- Note
- Blue dot represents internal thermocouple located on the ACP back pan.
 - Green dot represents cavity thermocouples located in the cavity between the back pan and plasterboard.
 - Pink dot represents cavity thermocouple between 3D architectural module and back pan.

5.0 Test measurements and results

The temperature measurements for the test specimen are included in Appendix C.

Table 5 in Appendix B includes observations of any significant behaviour of the specimen and details the occurrence of the various performance criteria specified in BS 8414-2:2015+A1:2017.

Photographs of the specimen are included in Appendix D.

Video recordings were also taken of the test. A copy of the video recording is available upon request from the test sponsor. The video of the test should be viewed in conjunction with the contents of this report.

6.0 *Application of test results*

6.1 Test limitations

The results of these fire tests may be used to directly assess fire hazard, but it should be recognised that a single test method will not provide a full assessment of fire hazard under all fire conditions.

These results only relate to the behaviour of the specimen of the element of construction under the particular conditions of the test. They are not intended to be the sole criteria for assessing the potential fire performance of the element in use, and they do not necessarily reflect the actual behaviour in fires.

6.2 Variations from the tested specimen

This report details methods of construction, the test conditions and the results obtained when the specific element of construction described here was tested following the procedure outlined in BS 8414-2:2015+A1:2017.

Any significant variation with respect to size, construction details, loads, stresses, edge or end conditions, other than that allowed under the field of direct application in the relevant test method, is not covered by this report.

6.3 Uncertainty of measurements

Because of the nature of reaction to fire testing and the consequent difficulty in quantifying the uncertainty of measurements obtained from a reaction to fire test, it is not possible to provide a stated degree of accuracy of result.

Appendix A Drawings of test assembly

The drawings of the test assembly in were provided by the test sponsor and modified and marked up by Jensen Hughes. These mark-ups to the drawings were:

- + Adjustments of curtain wall, balustrade and 3D architectural module sizes.
- + Inclusion of ground level balustrade and 3D architectural module.
- + Modification of wingwall layers as per built.
- + Addition of multi-leaders in Figure 9 to Figure 12

The leaders in the drawings represent the items listed in section 2.1. All measurements – unless indicated – are in millimetres.

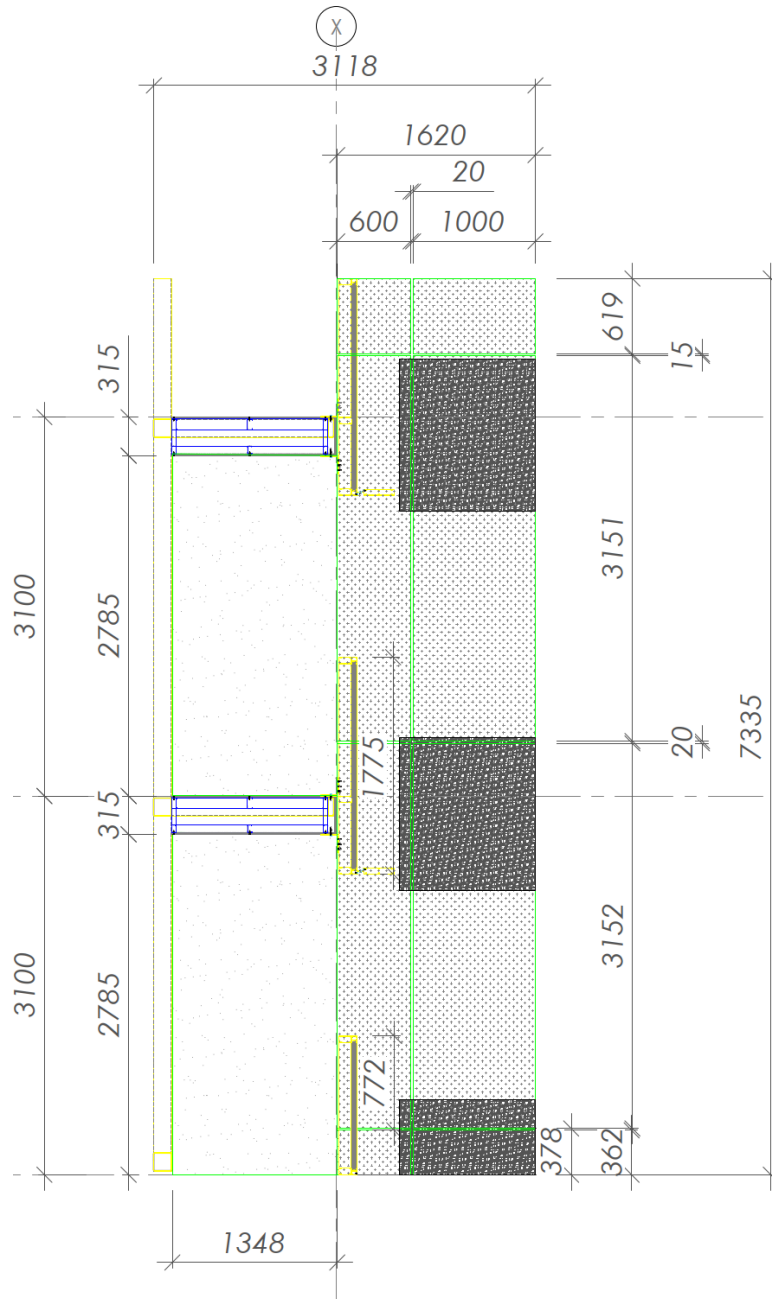

Figure 3 Elevation view of wing wall – ACP curtain wall overall measurements

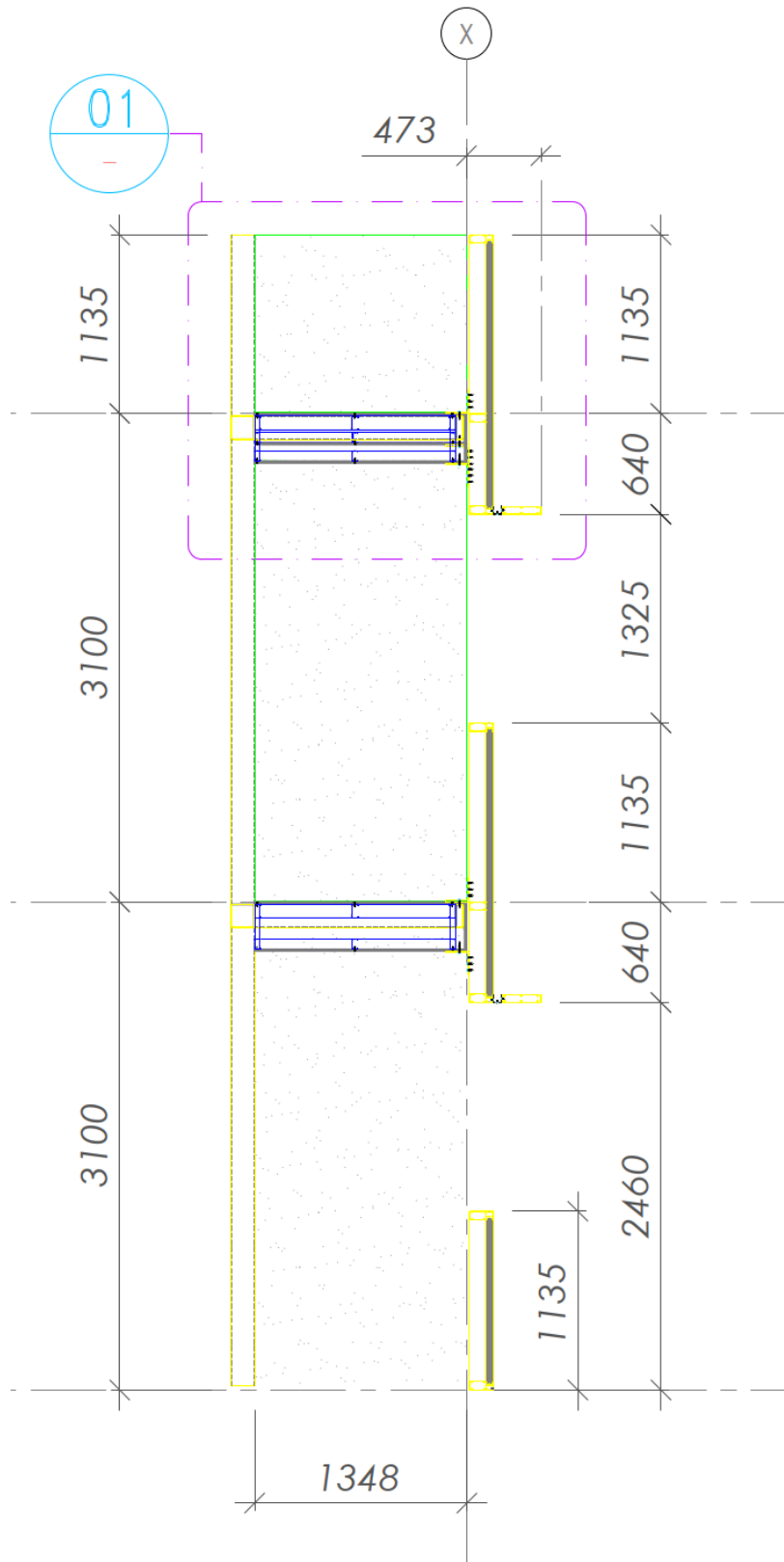

Figure 4 Elevation view of the wing wall – MgO board wall section -balustrade dimensions

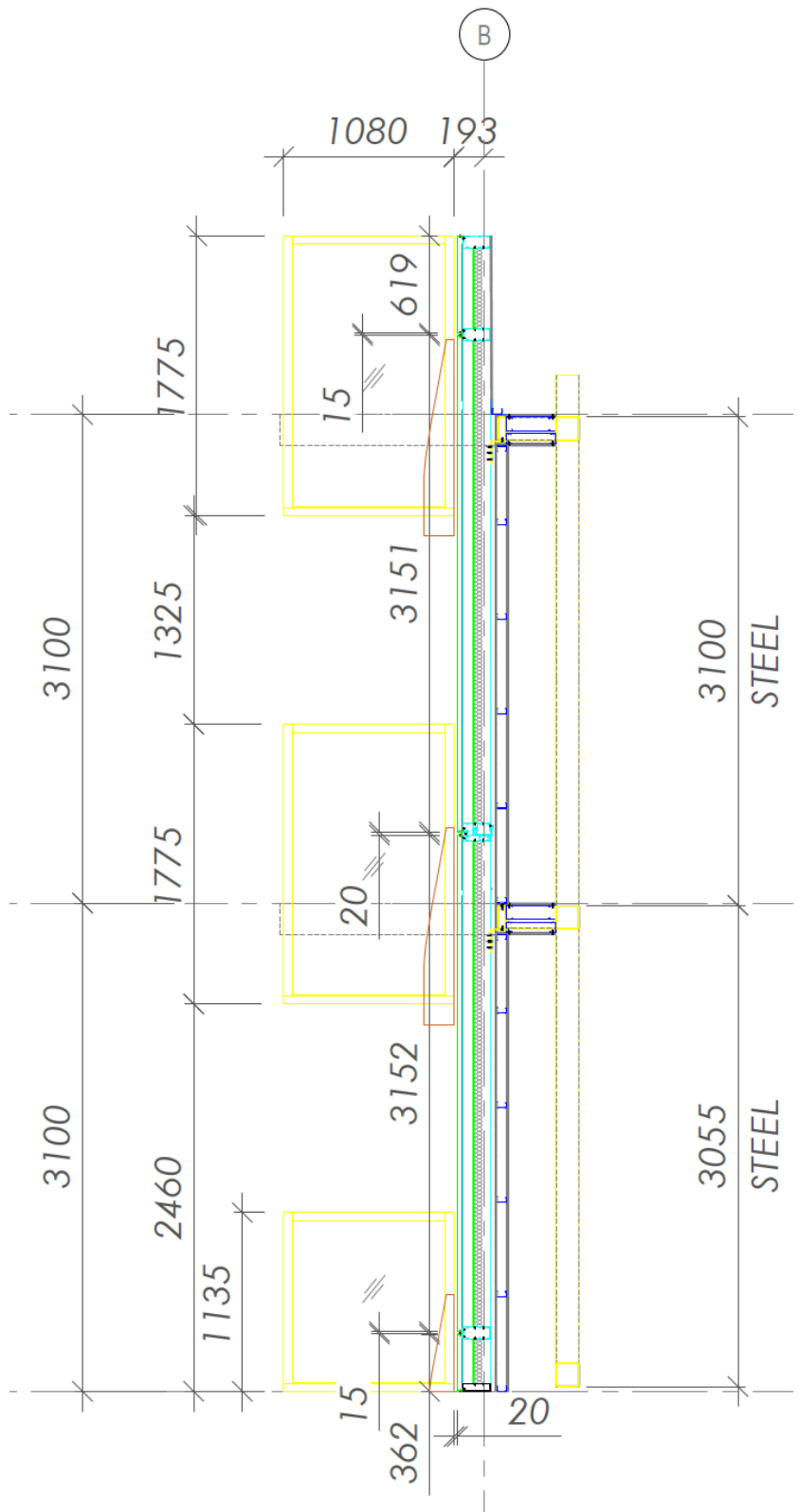

Figure 5 Elevation view of main wall balustrades and wing wall ACP curtainwall dimensions

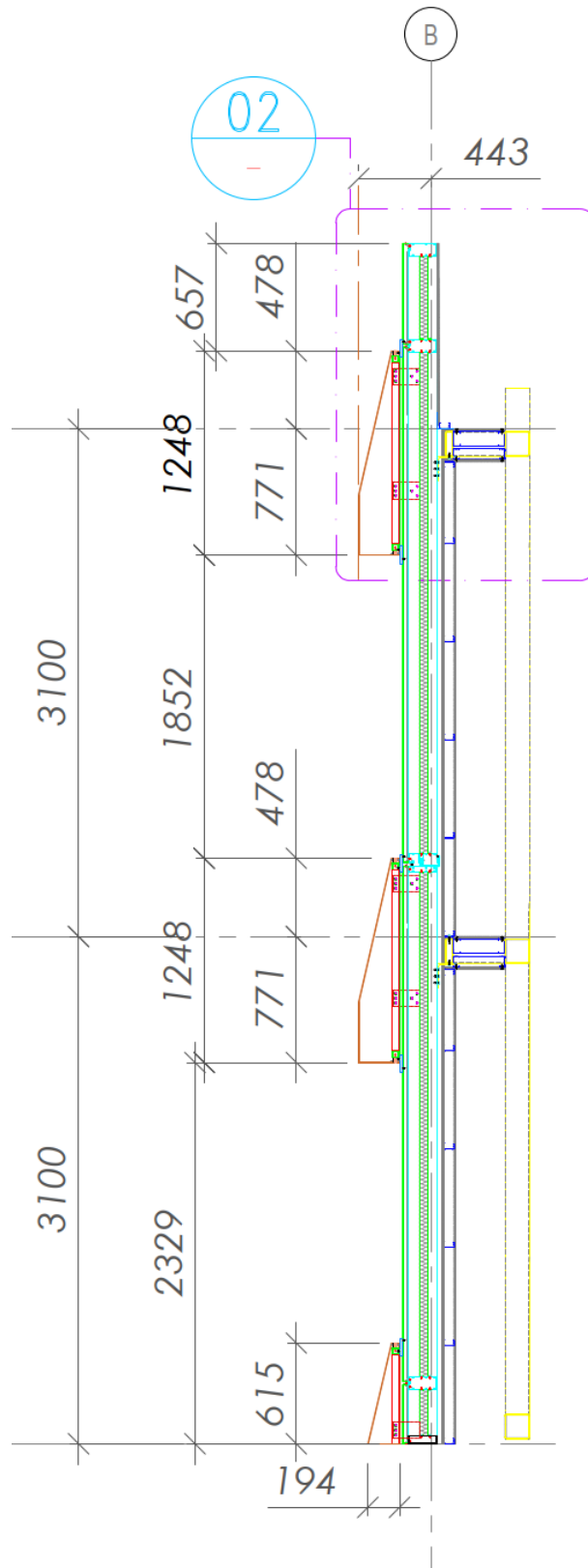

Figure 6 Elevation view – dimensions of 3D architectural modules

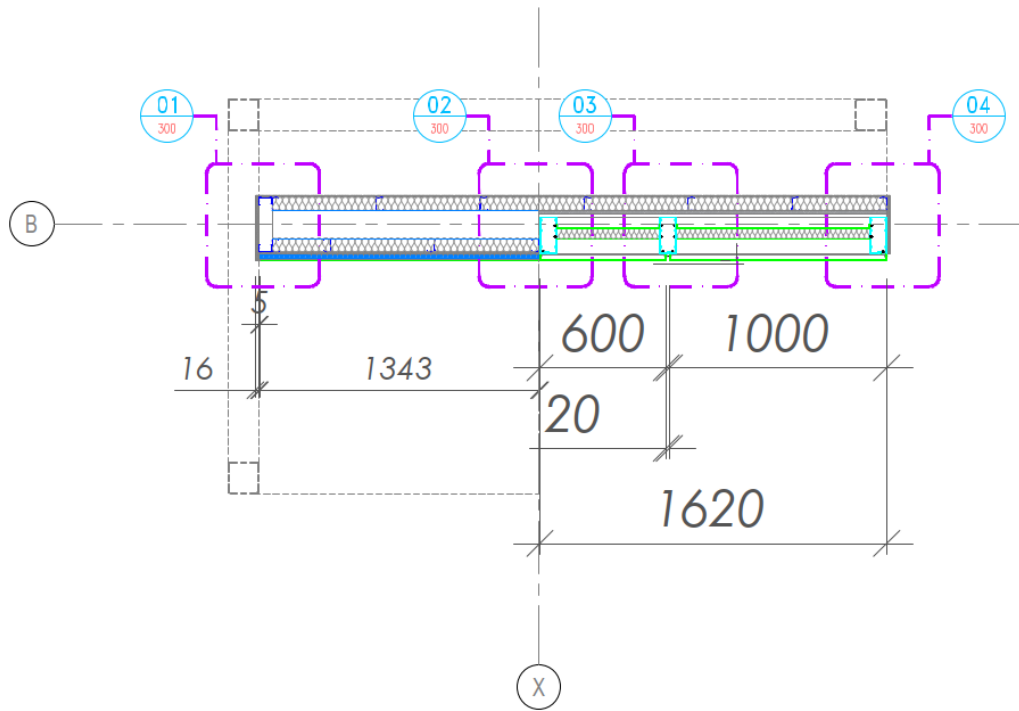

Figure 7 Plan view – wing wall

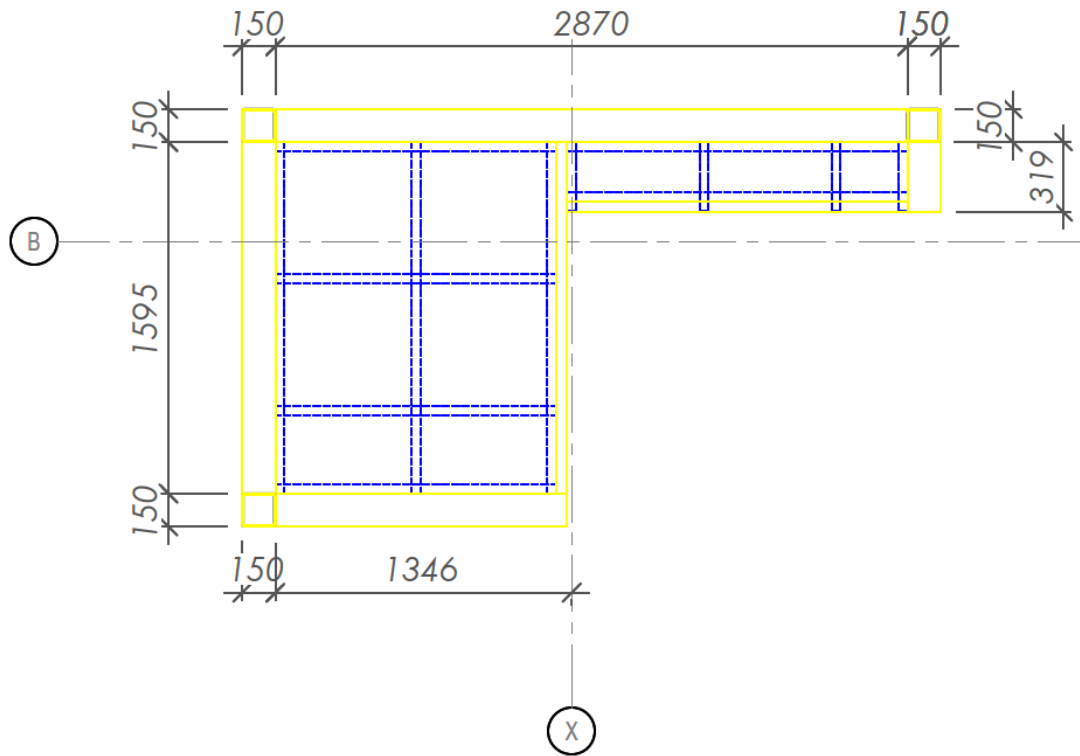

Figure 8 Plan view – steel frame layout

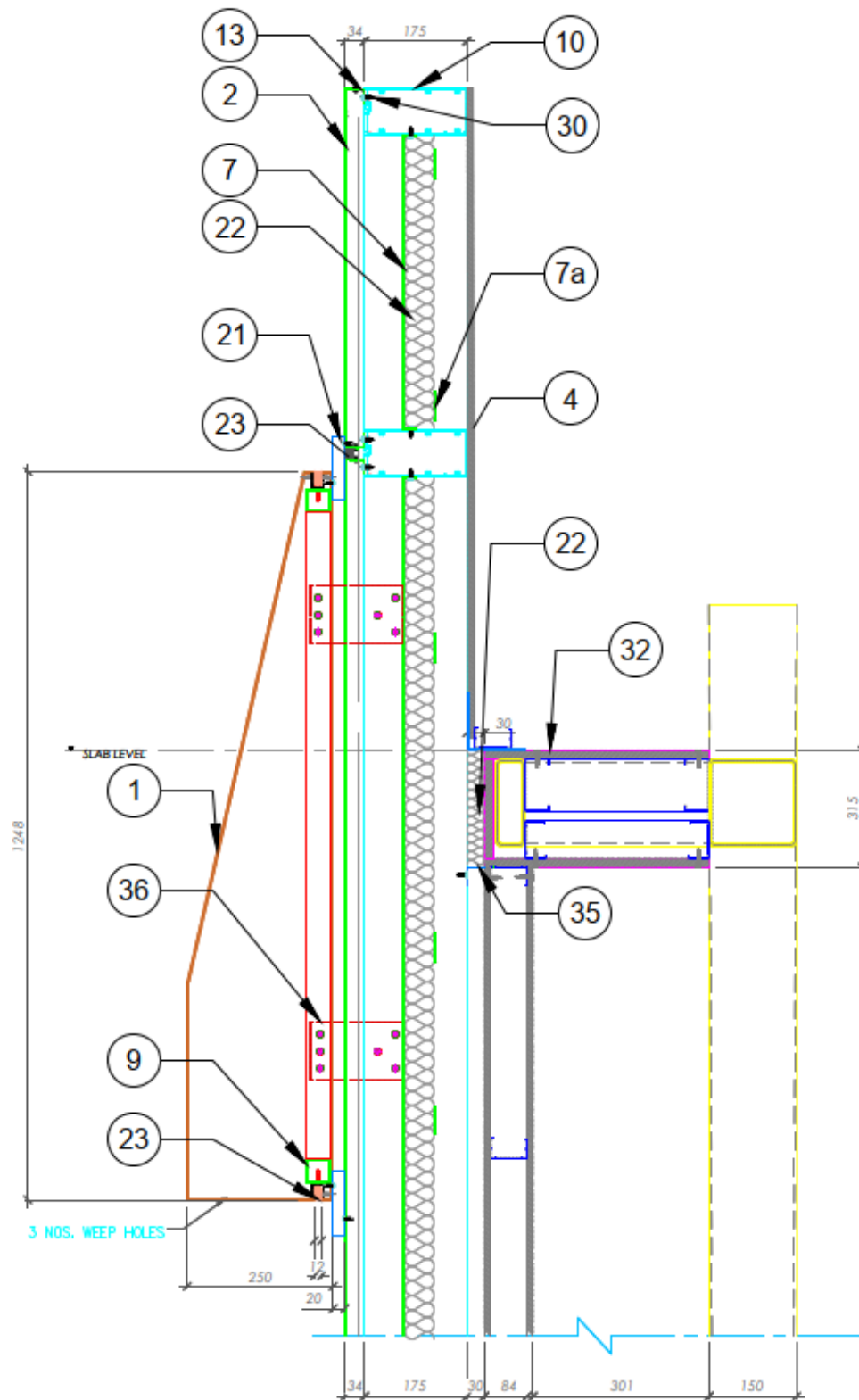

Figure 9 Cladding section details

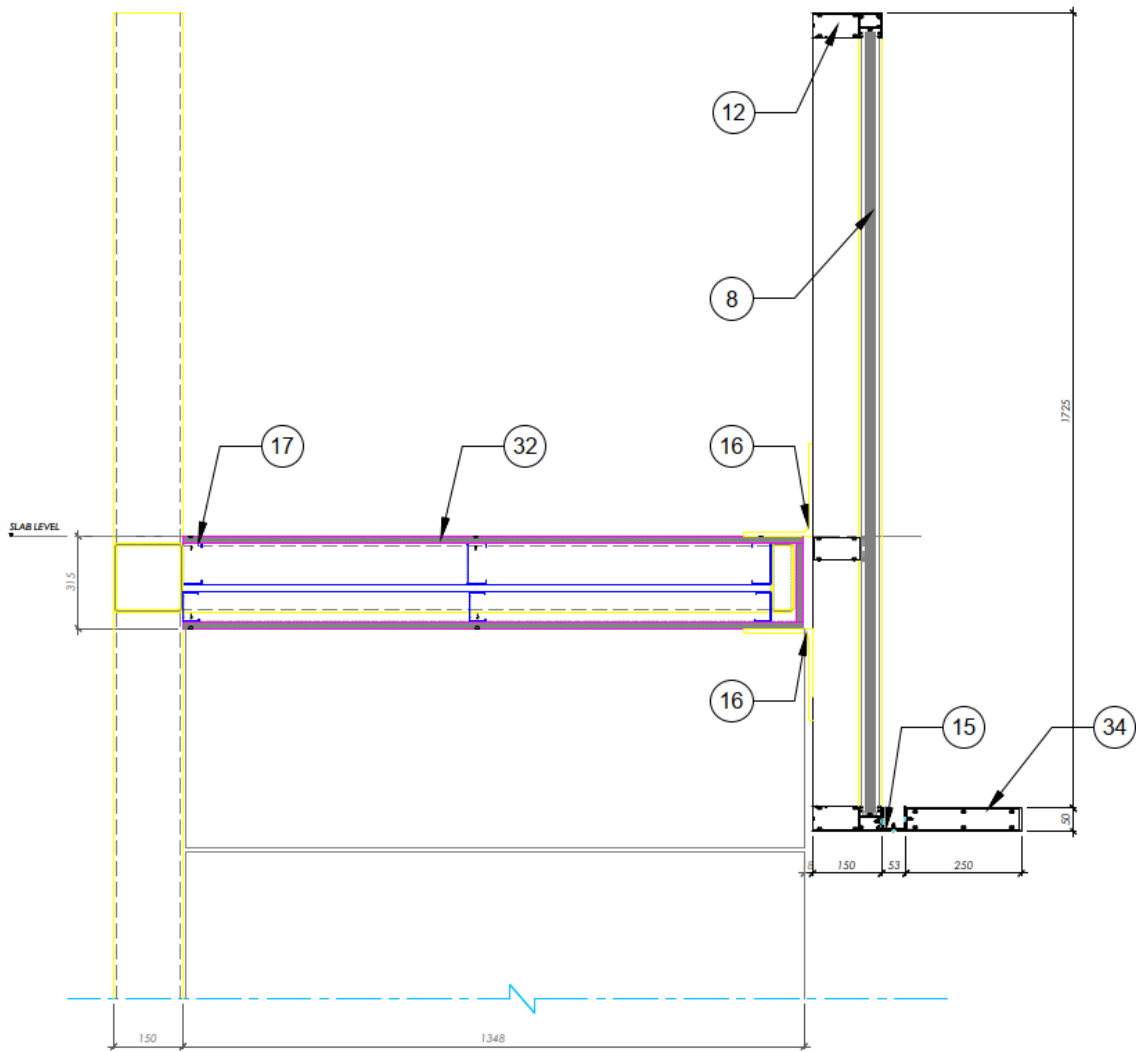

Figure 10 Balustrade section details

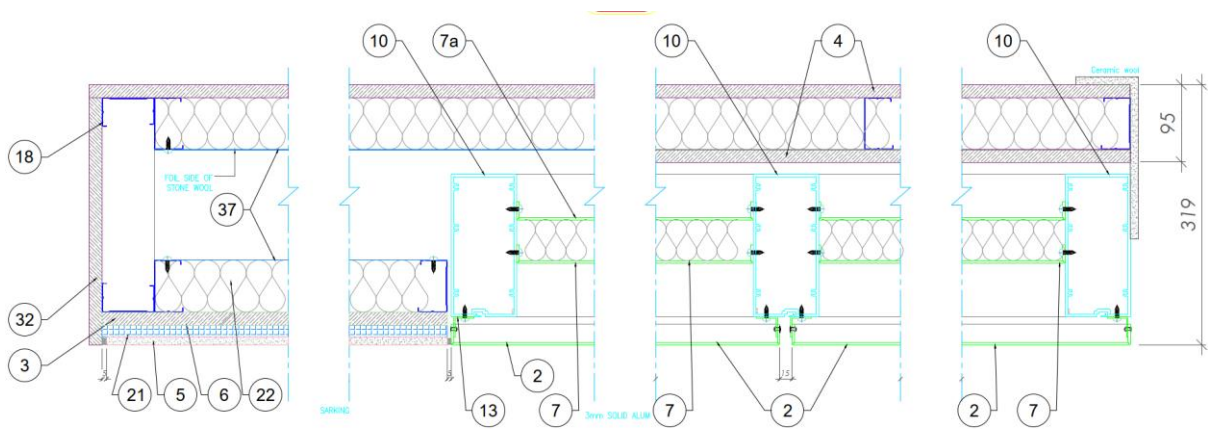

Figure 11 Cladding end and joint details

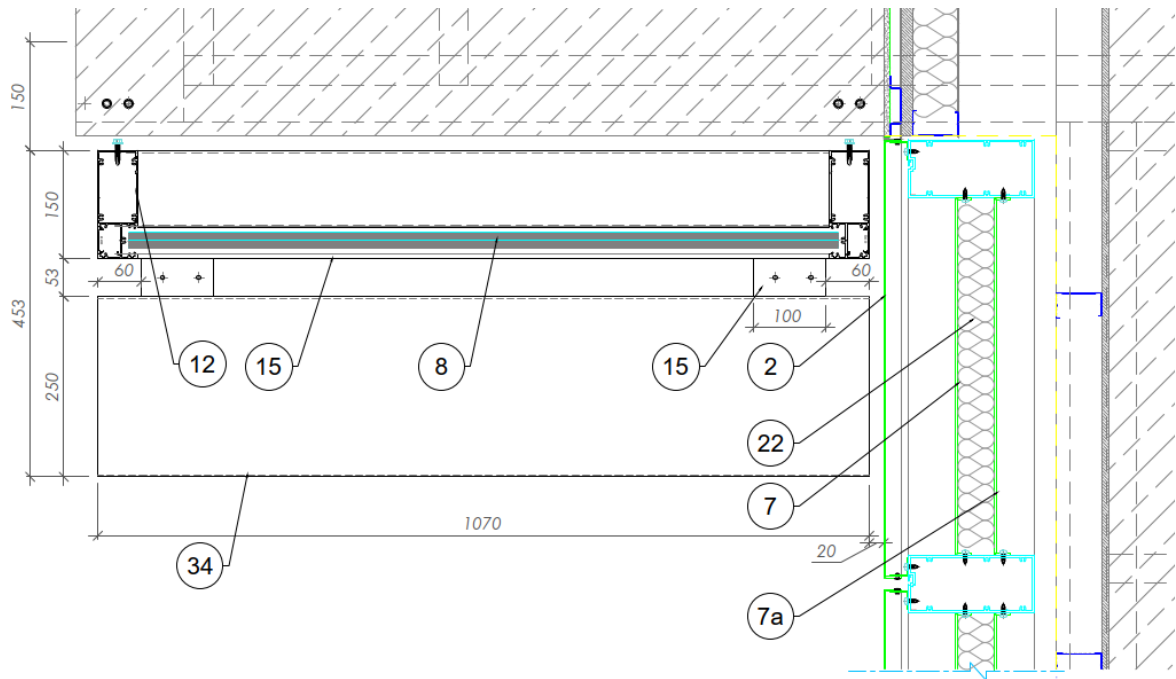

Figure 12 Balustrade plan details

Appendix B Test observations

B.1 Visual observation

Table 5 shows the observations of any significant behaviour of the specimen during the test.

Figure 13 shows the designations for the test specimen observations.

Table 5 Test observations

Time		Section	Observation
Min	Sec		
-5	00	All	Data collection started
0	00	All	The reaction to fire test started. The burner was ignited with the output set to a heat release rate of 100 kW.
6	45	A2	Lower edge of the aluminium cladding close to the ground level glazing started darkening.
7	40	A1	Flames intermittently exited towards the wing wall through the gap between the ground level balustrade and the wing wall.
11	02	A1.1	Flames intermittently hit the lower edge of the bottom aluminium cladding.
15	00	All	The burner output was set to a heat release rate of 300 kW.
15	56	A2	Flame reached the bottom of level 1 balustrade.
17	30	A2	The sealant on the lower glazing was on fire.
18	40	A2	Bubbles had appeared on the ground level glazing.
19	46	A1.2	Flames reached up to the aluminium cladding edge behind the glazing (A2).
21	23	A2	The ground level glazing cracked.
25	14	A2	The burner side edge of the aluminium cladding below level 1 balustrade had discoloured.
36	10	A2	The ground level glazing yellowed.
39	11	A2	The bottom section of level 1 glazing discoloured.
40	00	All	The burner was turned off.
40	54	A2	The exposed side of ground level glazing had independent flaming.
42	30	A2	Some smoke started emitting from the south side of the ground level glazing without any visible flame.
48	47	A2	The ground level glazing shattered.
51	43	A2	The ground level glazing shattered further.
60	00	All	The reaction to fire test was ended.



Figure 13 Designation for the test specimen observations

Appendix C Test data

C.1 Specimen temperatures

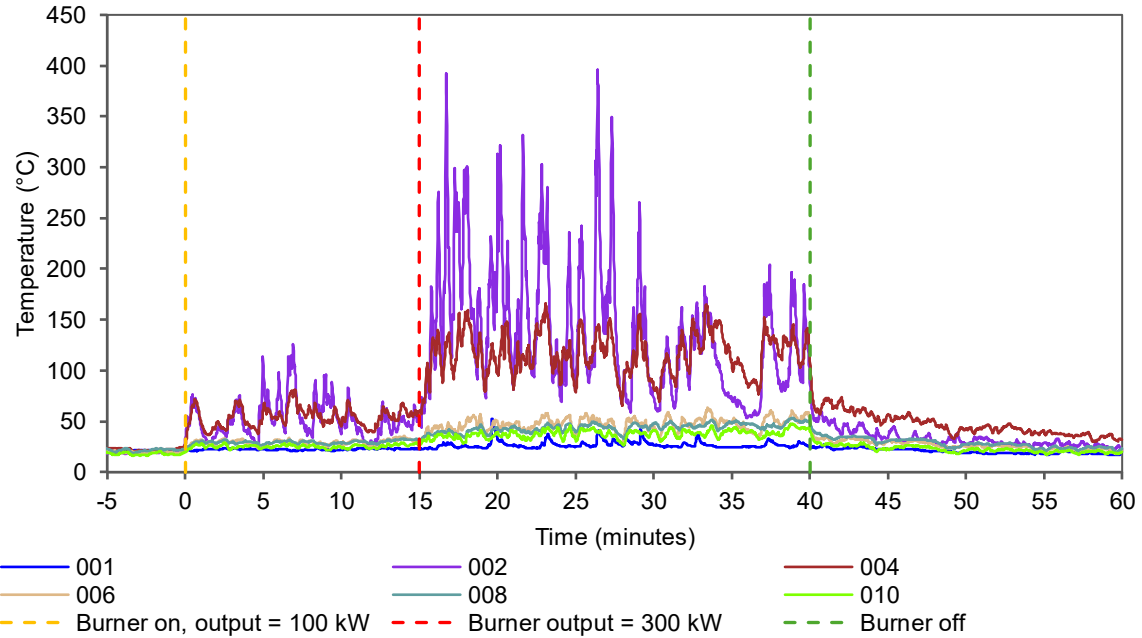

Figure 14 External surface temperatures at various heights on cladding close to the burner – temperature vs time

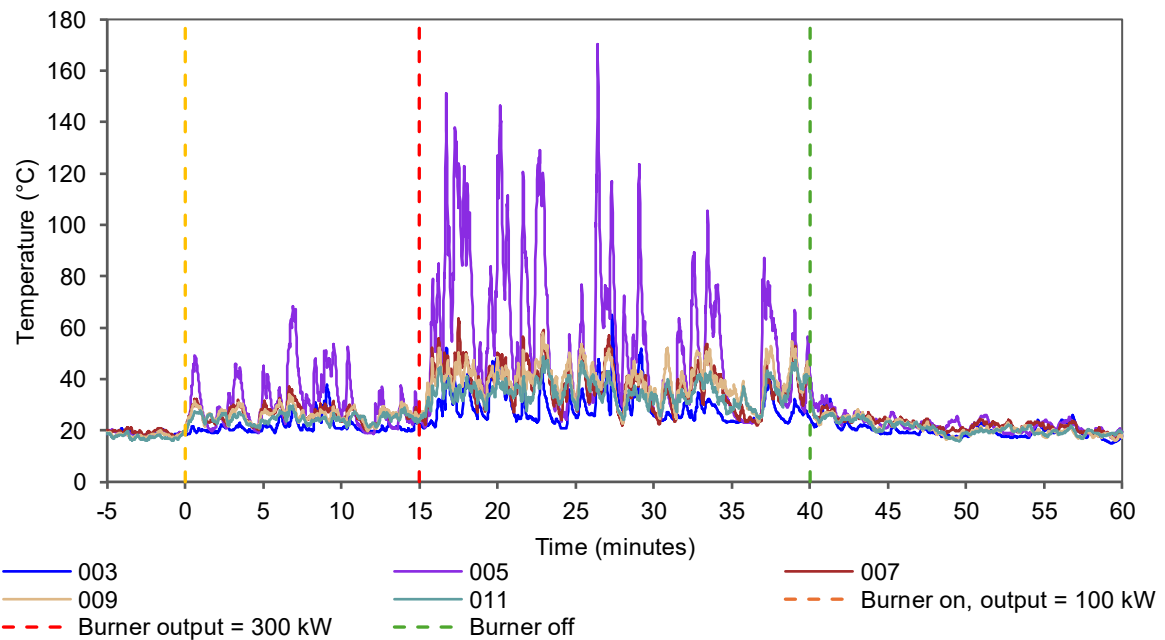

Figure 15 External surface temperatures at various heights on cladding away from the burner – temperature vs time

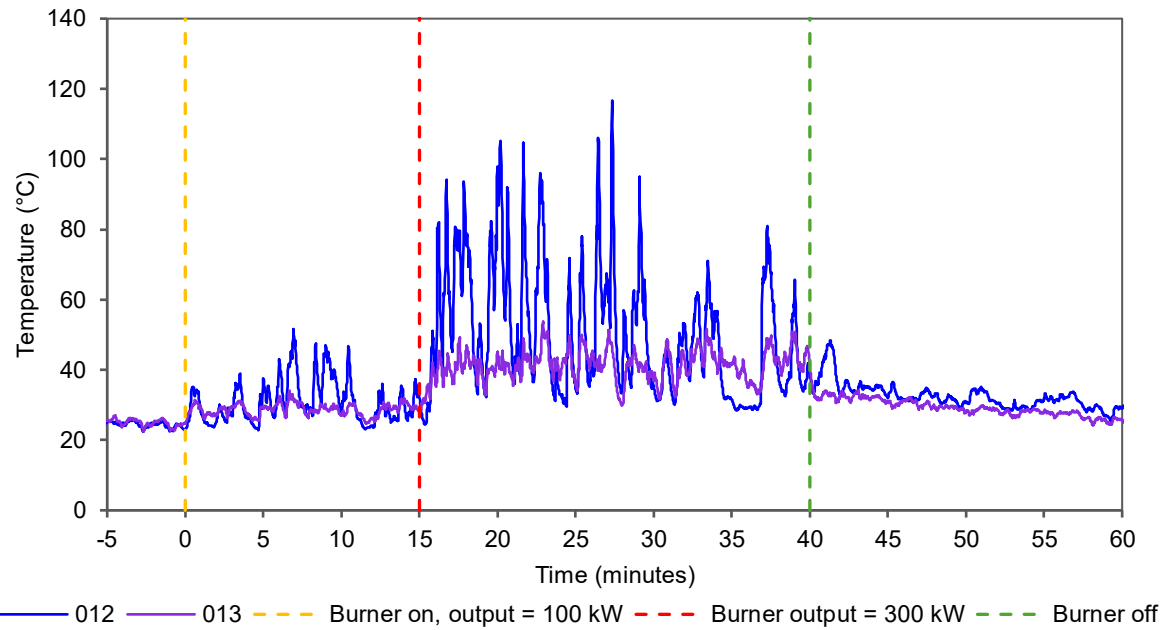

Figure 16 Cavity temperatures behind the 3D architectural modules – temperature vs time

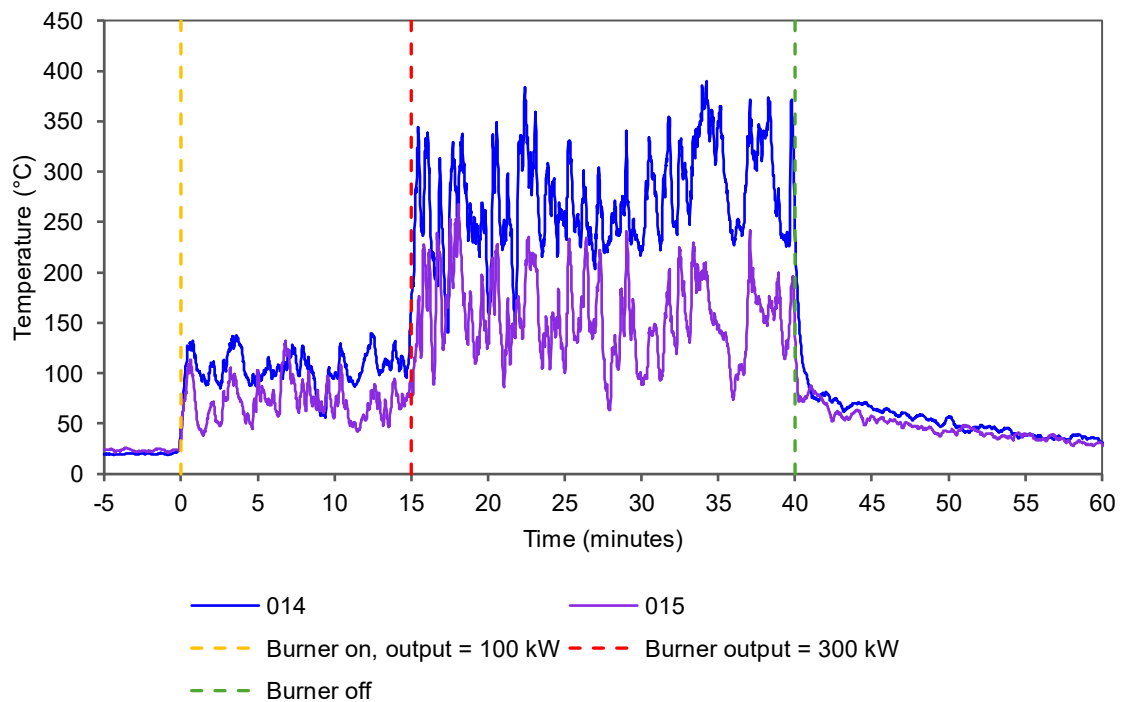

Figure 17 Surface temperature at level 1 balcony adjoining surfaces – temperature vs time

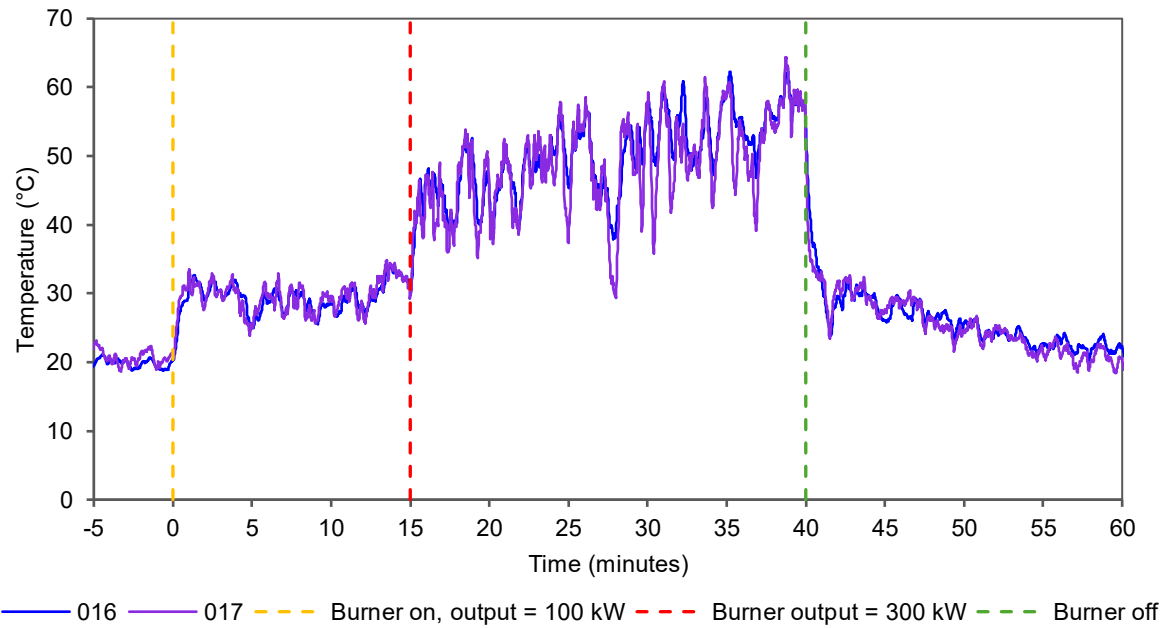

Figure 18 Surface temperature at level 2 balcony adjoining surfaces – temperature vs time

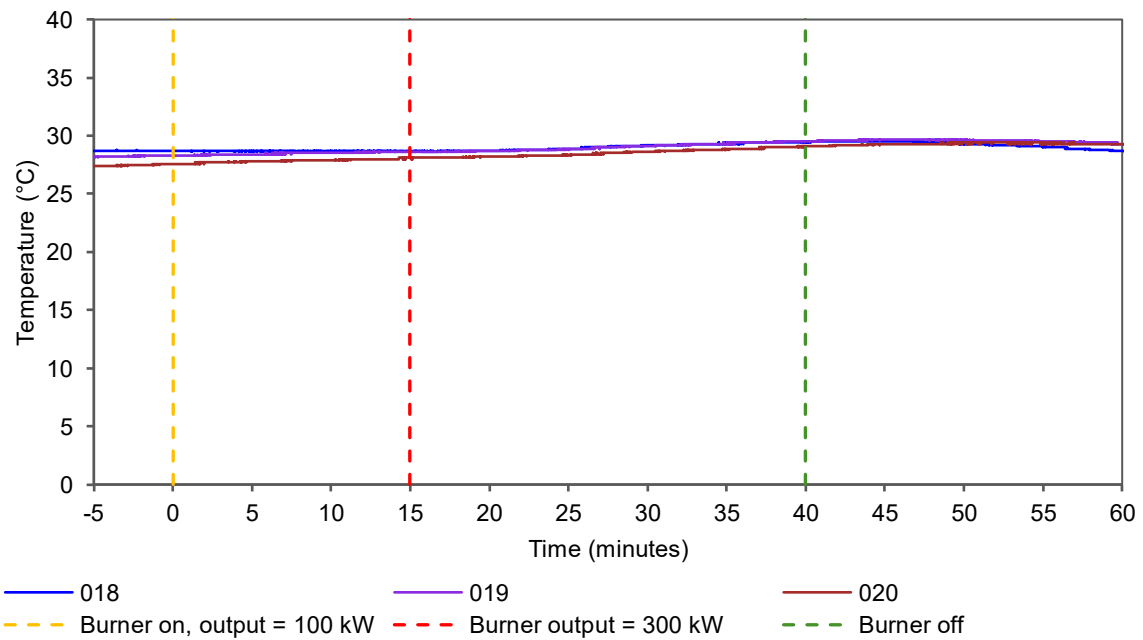

Figure 19 Internal temperatures located on the back pan on module 8 – temperature vs time

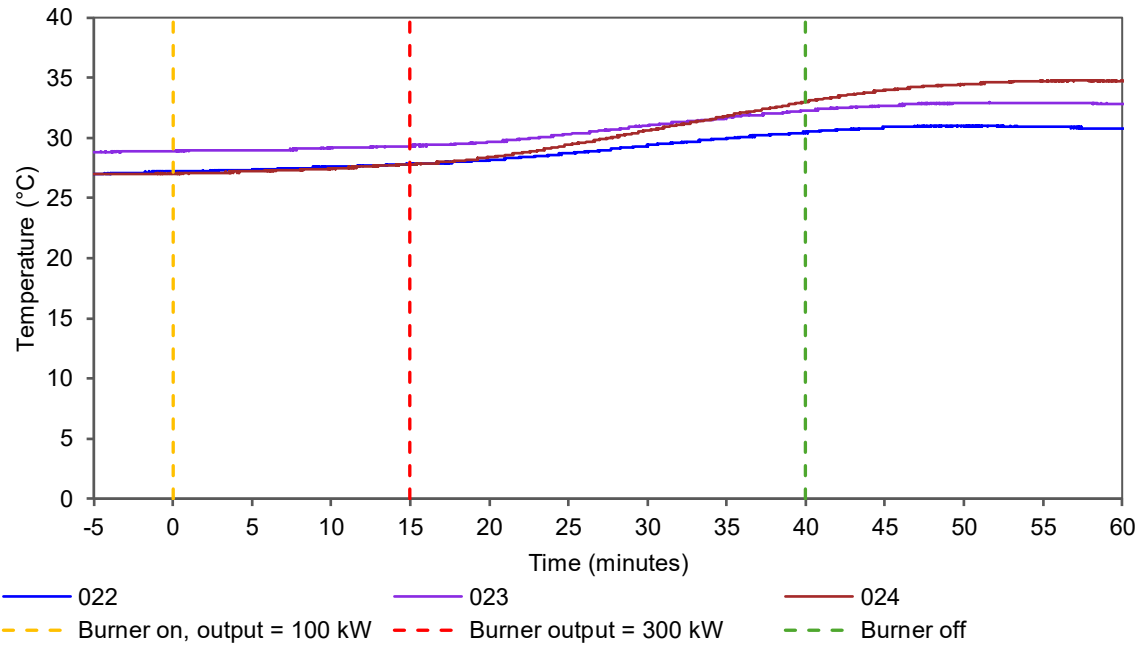

Figure 20 Internal temperatures located on the back pan on module 6 – temperature vs time

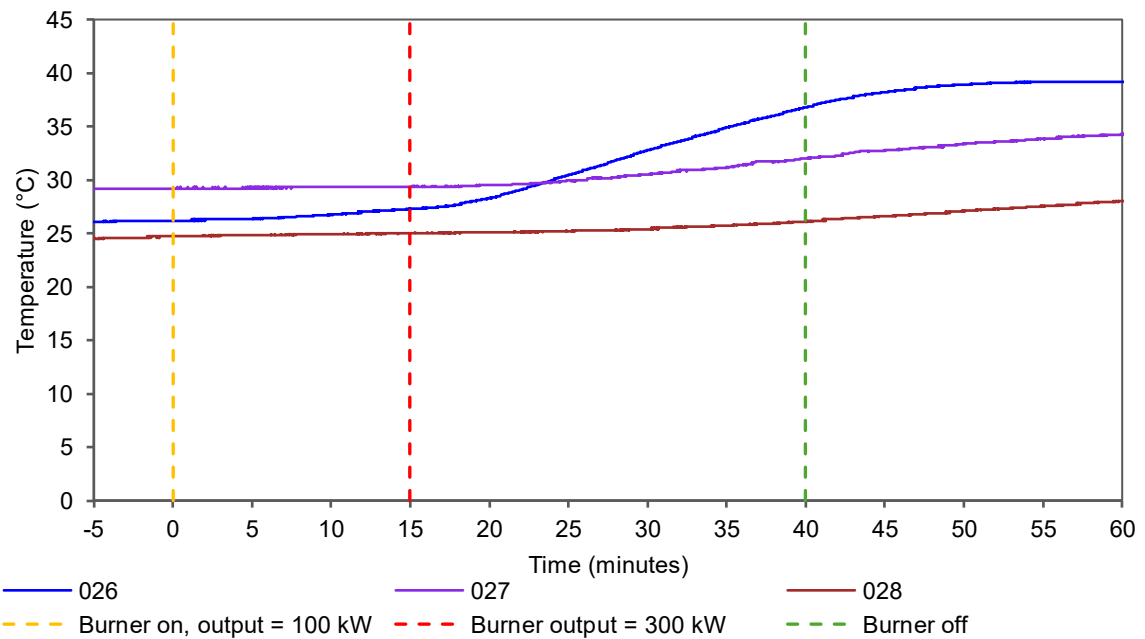

Figure 21 Internal temperatures located on the back pan on module 4 – temperature vs time

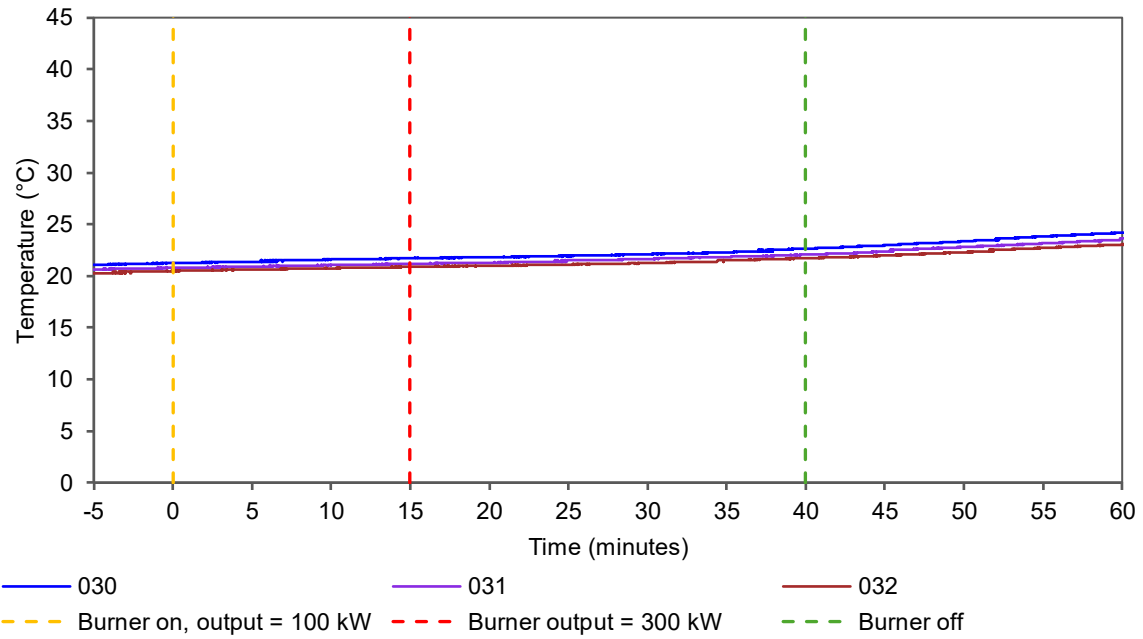

Figure 22 Internal temperatures located on the back pan on module 2 – temperature vs time

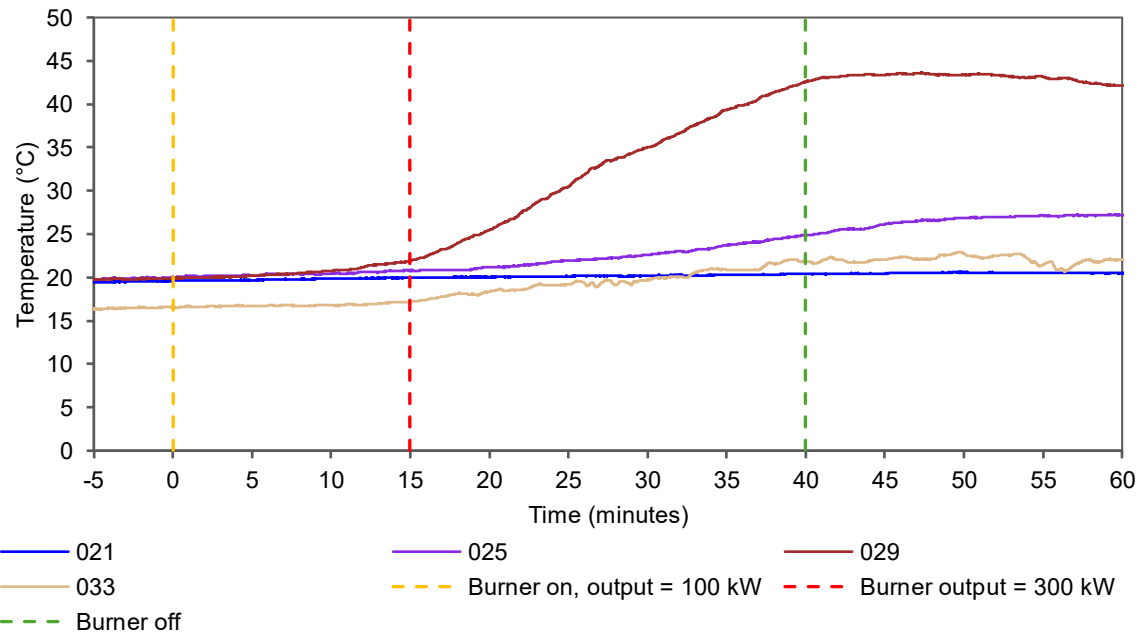

Figure 23 Cavity temperatures between the back pan and plasterboard of modules 2, 4, 6 and 8 – temperature vs time

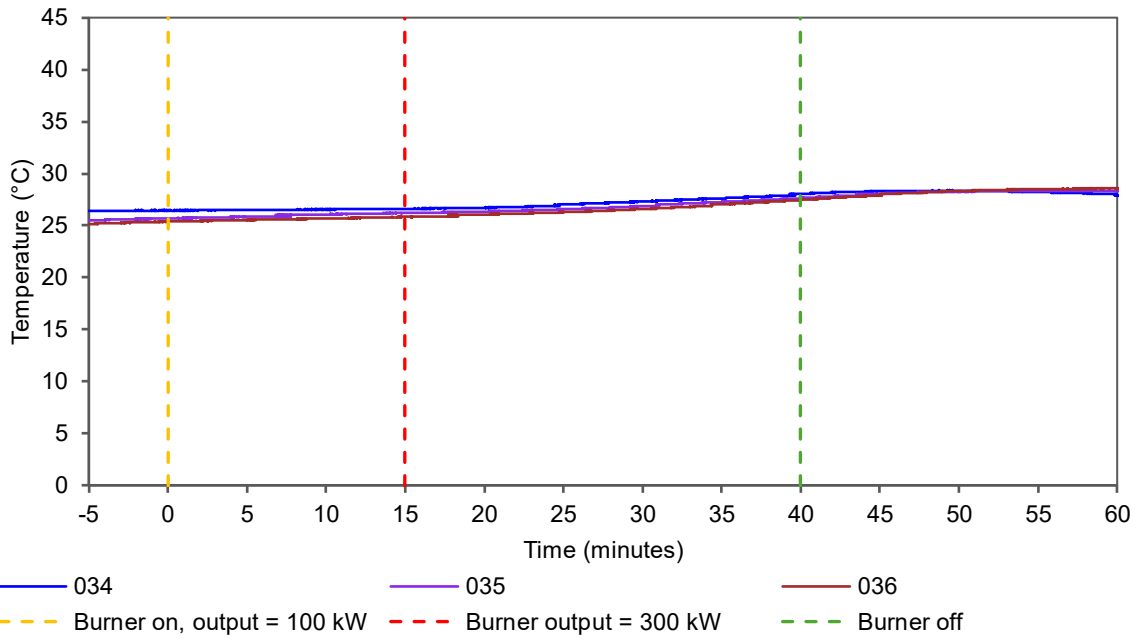

Figure 24 Internal temperatures located on the back pan on module 7 – temperature vs time

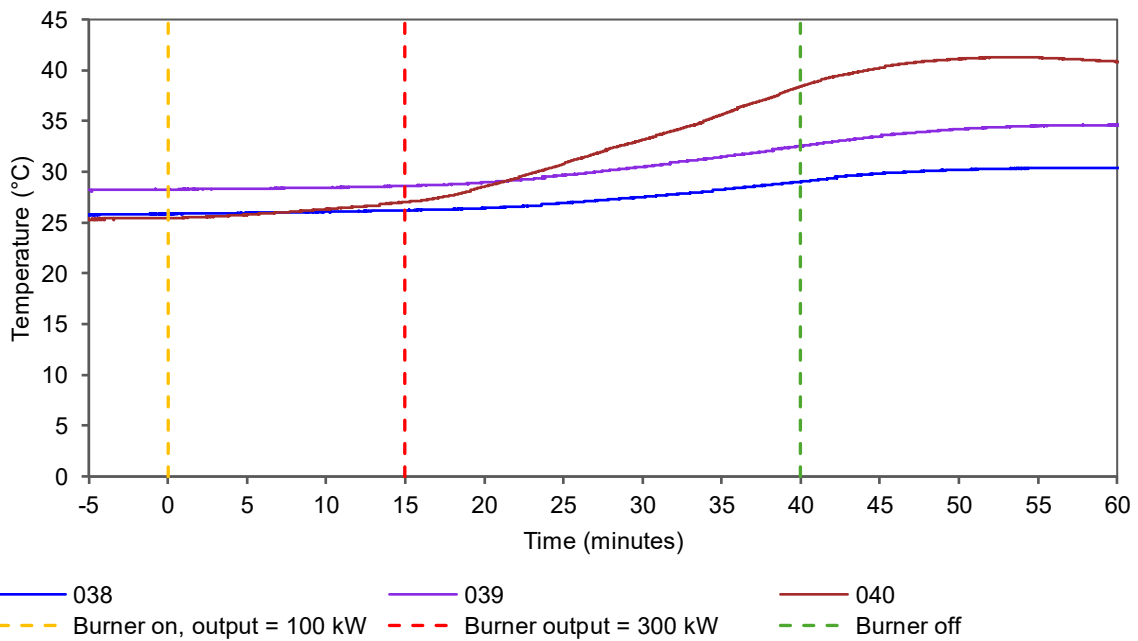

Figure 25 Internal temperatures located on the back pan on module 5 – temperature vs time

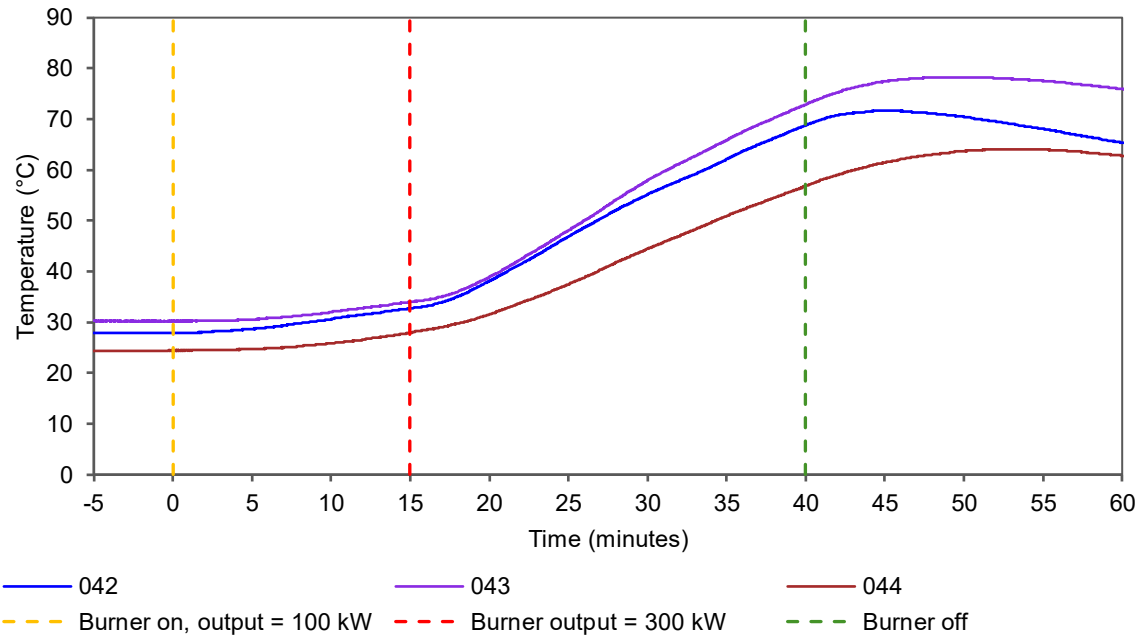

Figure 26 Internal temperatures located on the back pan on module 3 – temperature vs time

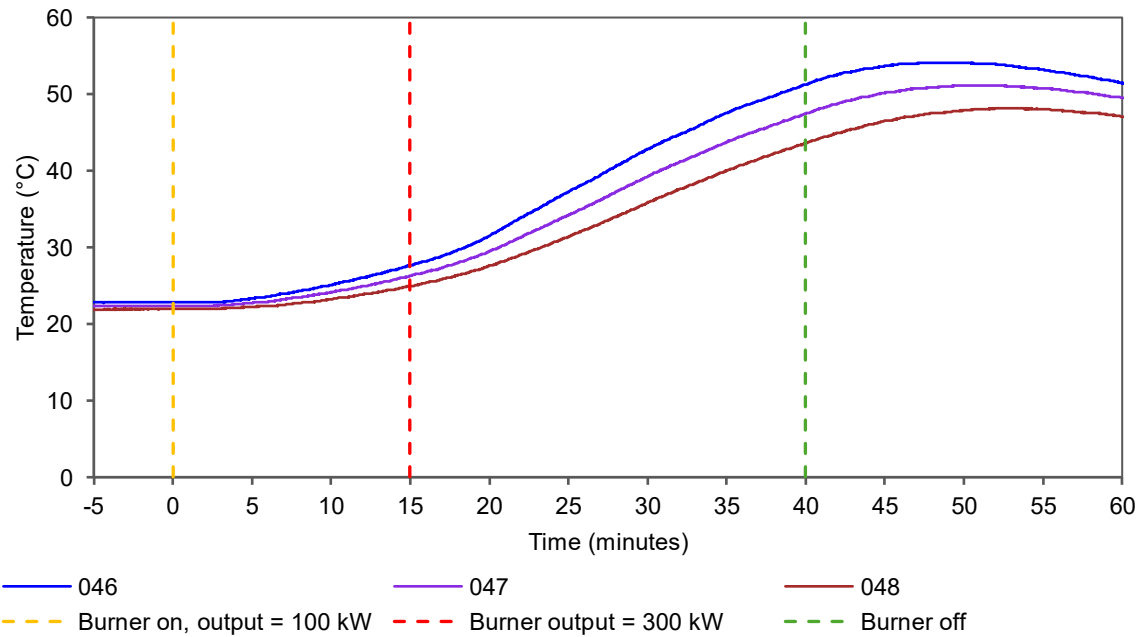

Figure 27 Internal temperatures located on the back pan on module 1 – temperature vs time

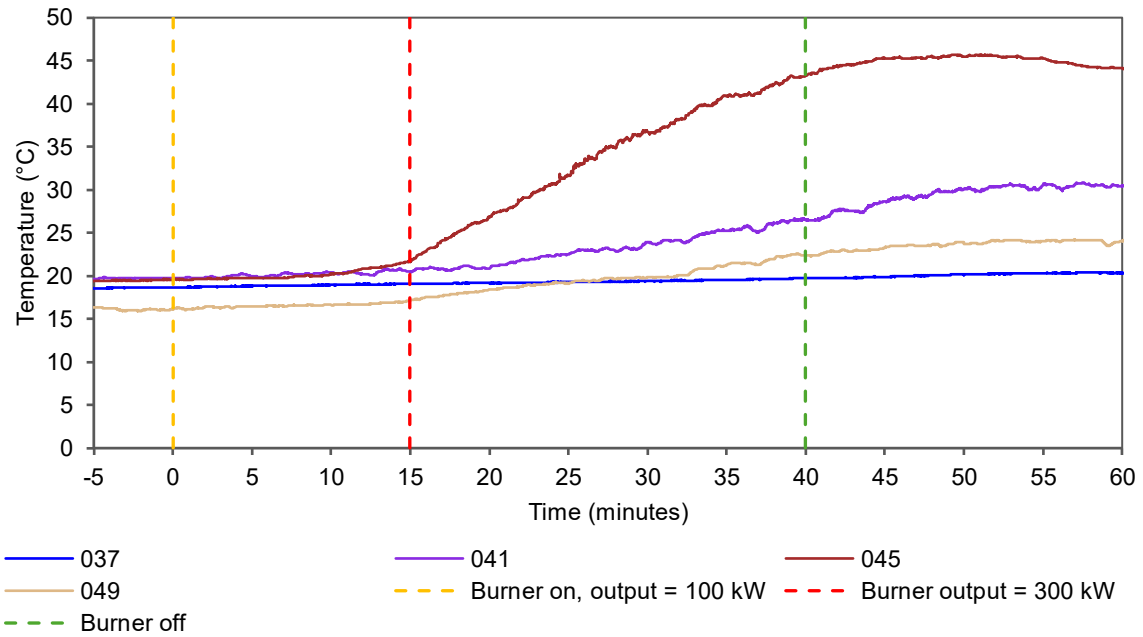

Figure 28 Cavity temperatures between the back pan and plasterboard of modules 1, 3, 5 and 7 – temperature vs time

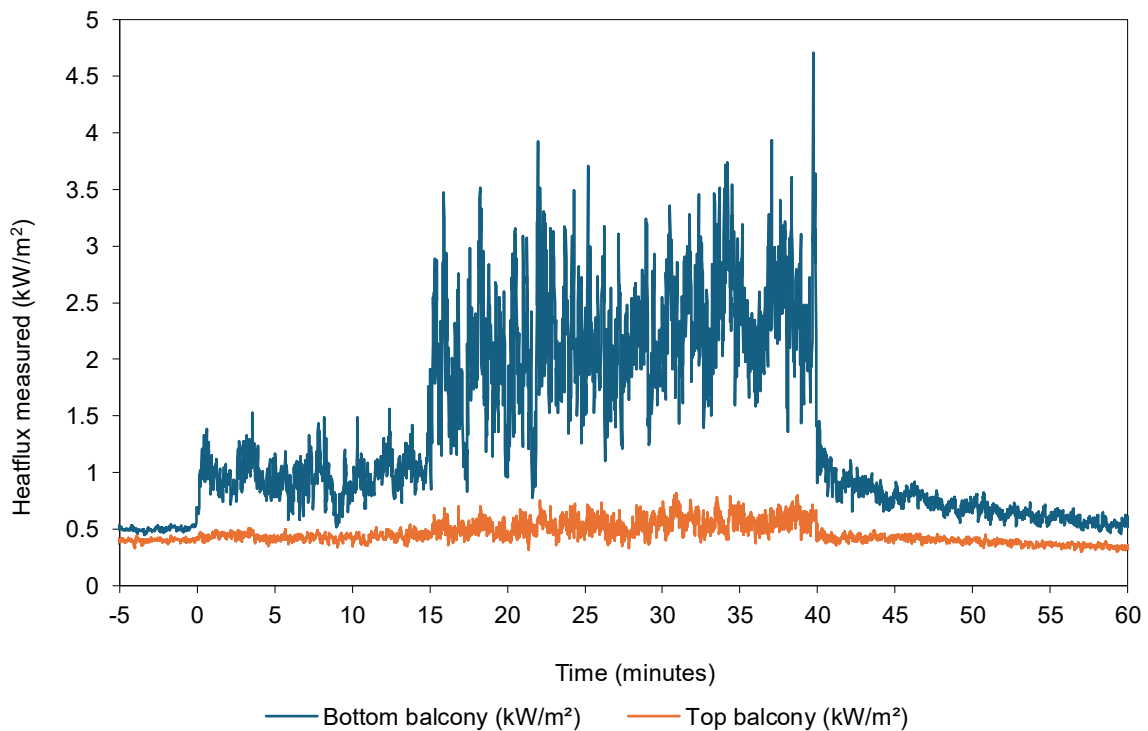

Figure 29 Measured heatflux data collected by the HFGs – Heat flux vs time

Appendix D Photographs



Figure 30 The specimen before the start of the test – exposed side.



Figure 31 The specimen 1 minute 58 seconds into the test with the burner at 100 kW.



Figure 32 The specimen 7 minutes 57 seconds into the test with the burner at 100 kW.



Figure 33 The specimen 14 minutes 58 seconds into the test with the burner at 100 kW.



Figure 34 The specimen 15 minutes 57 seconds into the test – 57 seconds after the burner output was increased to 300 kW.



Figure 35 The specimen 17 minutes 30 seconds into the test – sealant around the ground level balustrade on fire.



Figure 36 The specimen 18 minutes 40 seconds into the test – formation of bubbles in the PVB interlayer of glazing.



Figure 37 The specimen 25 minutes 57 seconds into the test – 10 minutes 57 seconds after the burner output was increased to 300 kW.



Figure 38 The specimen 35 minutes 58 seconds into the test – 20 minutes 58 seconds after the burner output was increased to 300 kW.



Figure 39 The specimen 39 minutes 57 seconds into the test – 24 minutes 57 seconds after the burner output was increased to 300 kW.



Figure 40 The specimen 40 minutes 58 seconds into the test – 58 seconds after the burner was turned off.



Figure 41 The specimen 59 minutes 57 seconds into the test – 3 seconds before the end of test.



Figure 42 Specimen at the end of the test.

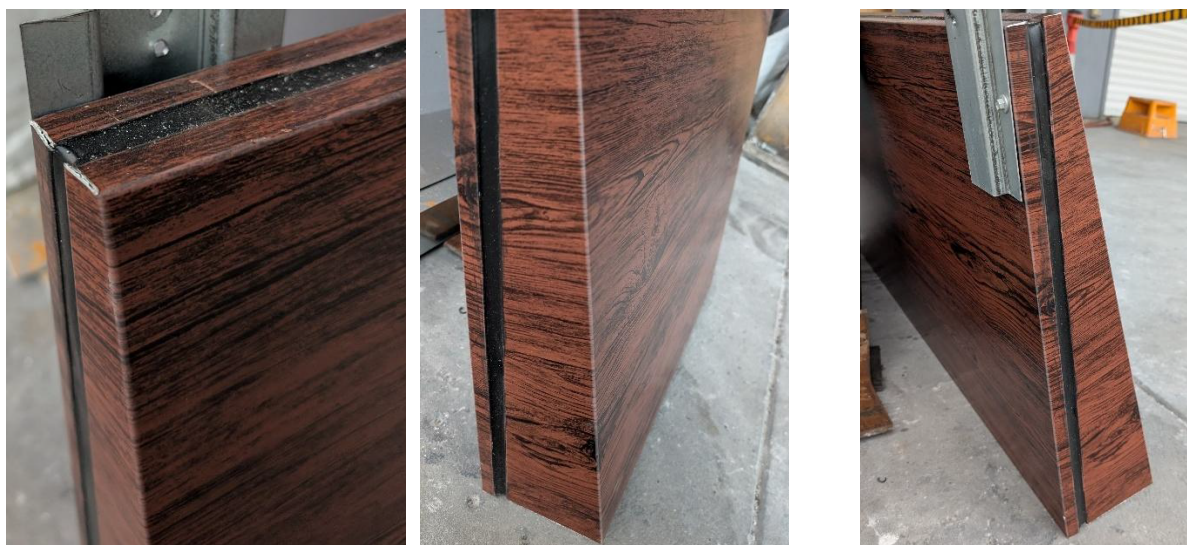

Figure 43 Post test condition of the ground level architectural module.

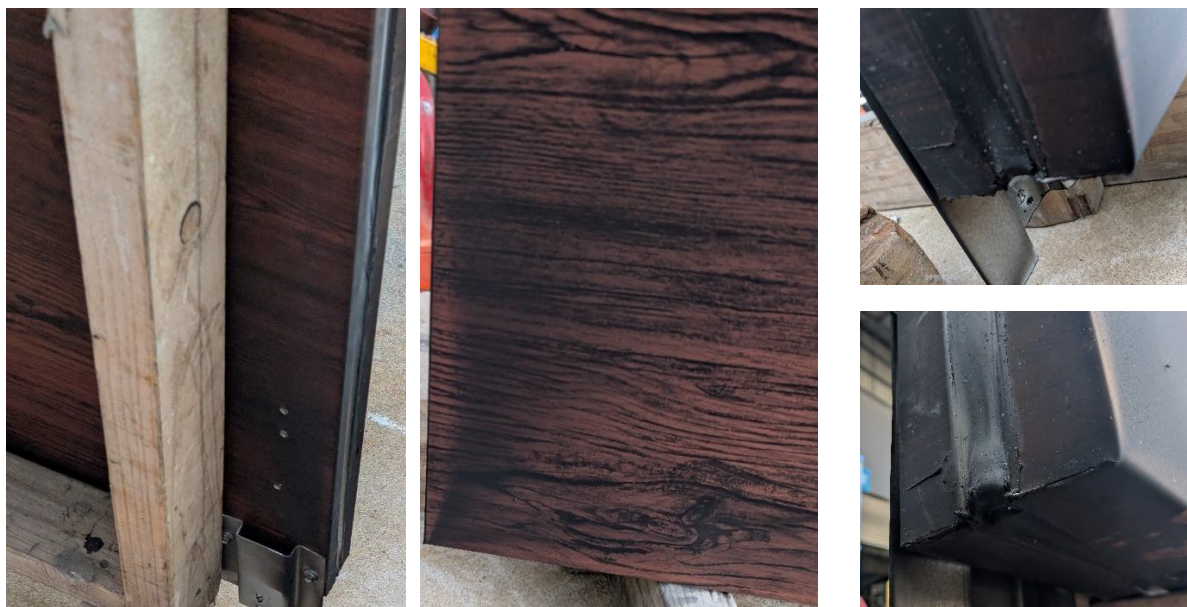

Figure 44 Post test condition of level 1 architectural module.



Figure 45 Post test condition of the ground level balustrade.



Figure 46 Post test condition of level 1 balustrade.



Figure 47 Post test condition behind the MgO board.



Figure 48 Post test condition of the ACP back pan.



Figure 49 test jig during construction.

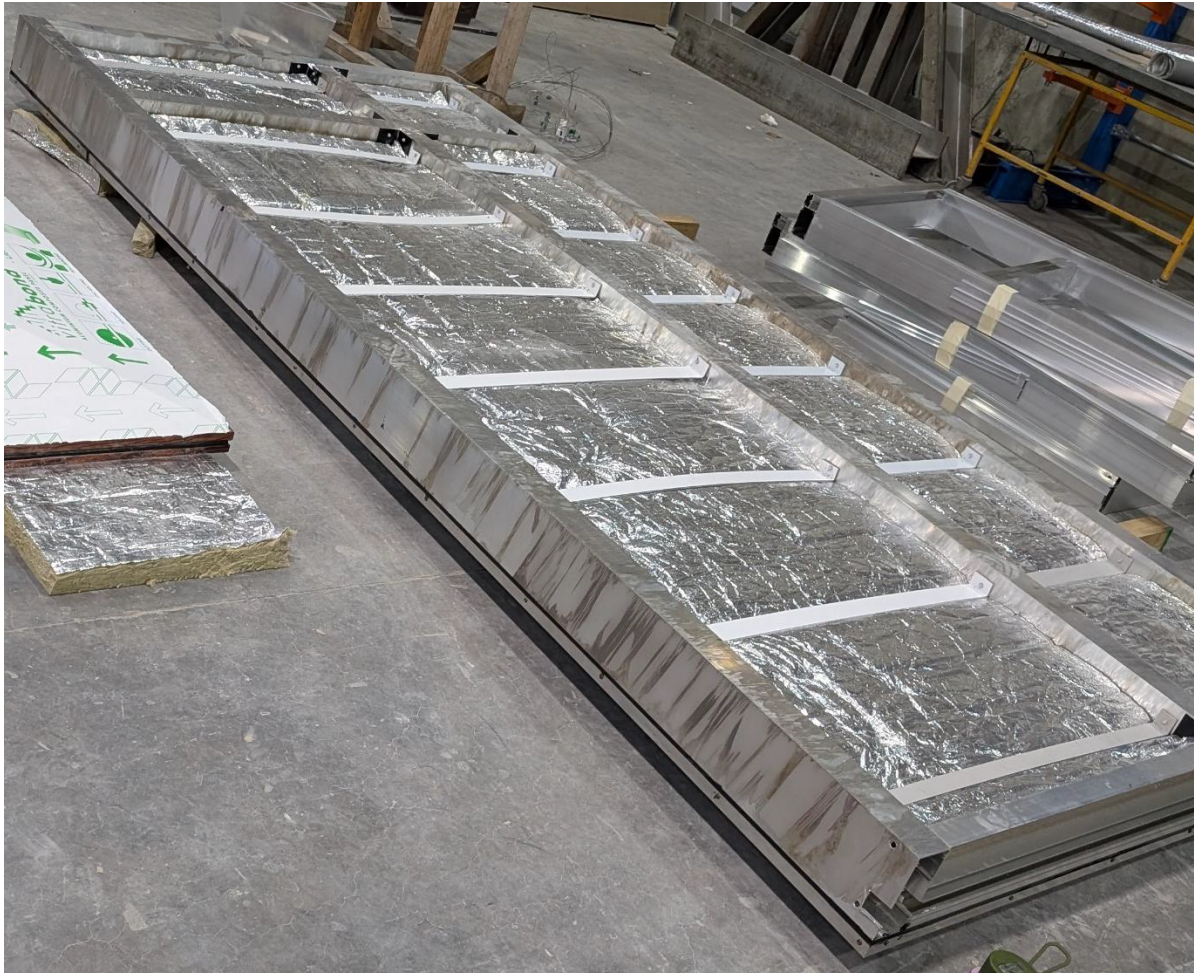

Figure 50 unexposed side of ACP curtainwall module.

Appendix E Chemical analysis results



UNSW RESEARCH INFRASTRUCTURE

Chemical Consulting Laboratory

Mark Wainwright Analytical Centre
UNSW Sydney NSW 2052 Australia

T: +61(2) 9348 1400 | E: ccl@unsw.edu.au
W: www.analytical.unsw.edu.au/contact-us/commercial-consulting
ABN 57 195 873 179 | CRICOS Provider Code 00098G

Test Report

ANALYSIS OF CLADDING SAMPLE

For

Company: Jensen Hughes

Contact: [REDACTED]

Date: 4 April 2025

Project No: 25082

Prepared by: [REDACTED]

Approved by: [REDACTED]

COMMERCIAL-IN-CONFIDENCE

Any use of the Test Report, use of any part of it, use of the names University of New South Wales or UNSW, use of the name of any Unit of UNSW, or use of the name of the consultant in direct or indirect advertising or publicity is strictly forbidden.



Analysis of Cladding Sample

1. SAMPLES

One envelope containing one ACP core was received for analysis. The sample was identified as follows:

CCL sample coding	Client sample coding
25082-1	ACP

CCL has been asked to identify the polymer and the filler (s) in the sample by FT/IR, quantitate and identify the mineral filler in the sample and classify them in accordance with the ICA cladding scheme.

2. METHODOLOGY AND RESULTS

The aluminium metals were removed from the ACPs cladding polymers, and the flat surface of the polymer sample was abraded to remove any surface adhesive. The surface of the sample was analysed directly by FTIR. The FT-IR spectrum is presented in Figure 1.

The core of the sample was then ashed to determine its percentage mineral content (Table 1). If sufficient (>0.5 g) ash was found, it was analysed for elemental composition by X ray fluorescence spectroscopy. Results are presented in Table 2.

Table 1 Ash content of 25082-1

Sample coding	Ash content (w/w%)
25082-1	40.1

Table 2 Elemental composition of 25082-1

Element Oxide wt. %	25082-1
Na ₂ O	0.12
MgO	78.74
Al ₂ O ₃	0.38
SiO ₂	4.79
P ₂ O ₅	0.12
SO ₃	0.42
K ₂ O	0.04
CaO	7.92
TiO ₂	2.26
V ₂ O ₅	<0.01
Cr ₂ O ₃	<0.01
Mn ₃ O ₄	0.05
Fe ₂ O ₃	0.47
NiO	<0.01
CuO	<0.01
ZnO	0.02
SrO	0.01
ZrO ₂	<0.01
BaO	0.13
HfO ₂	<0.01
PbO	0.01
SnO ₂	0.01
CoO	<0.01
L.O.I.	ND

NOTE: (i) L.O.I.= loss on ignition at 1,050 °C.
(ii) ND = not determined



3. CONCLUSIONS

The cladding Sample #1 consisted of 45.7% magnesium hydroxide, 5.7% calcium carbonate, 5.3% other inert material and approximately 43.3% Polyethylene polymer.

The cladding sample #1 is classified as ICA category A.

The ICA Classification assigned is correct as per the September 2020 revision of the ICA Guidelines.

The calculation for magnesium hydroxide content assumes that all magnesium found is present as the hydroxide. The calculation for calcium carbonate content assumes that all calcium found is present as the carbonate.

The reader is reminded that we can only analyse and classify the content of samples actually presented to us. We can offer no guarantee that this composition or classification is valid for cladding as a whole, because some types of cladding can be inhomogeneous, and a sample may not be representative of the cladding as a whole. Anyone using our results should consider these sampling issues and uncertainties before they generalise the results we present to anybody of cladding as a whole.

██████████
Technical Officer

Chemical Consulting Laboratory

Mark Wainwright Analytical Centre, UNSW

4 April 2025



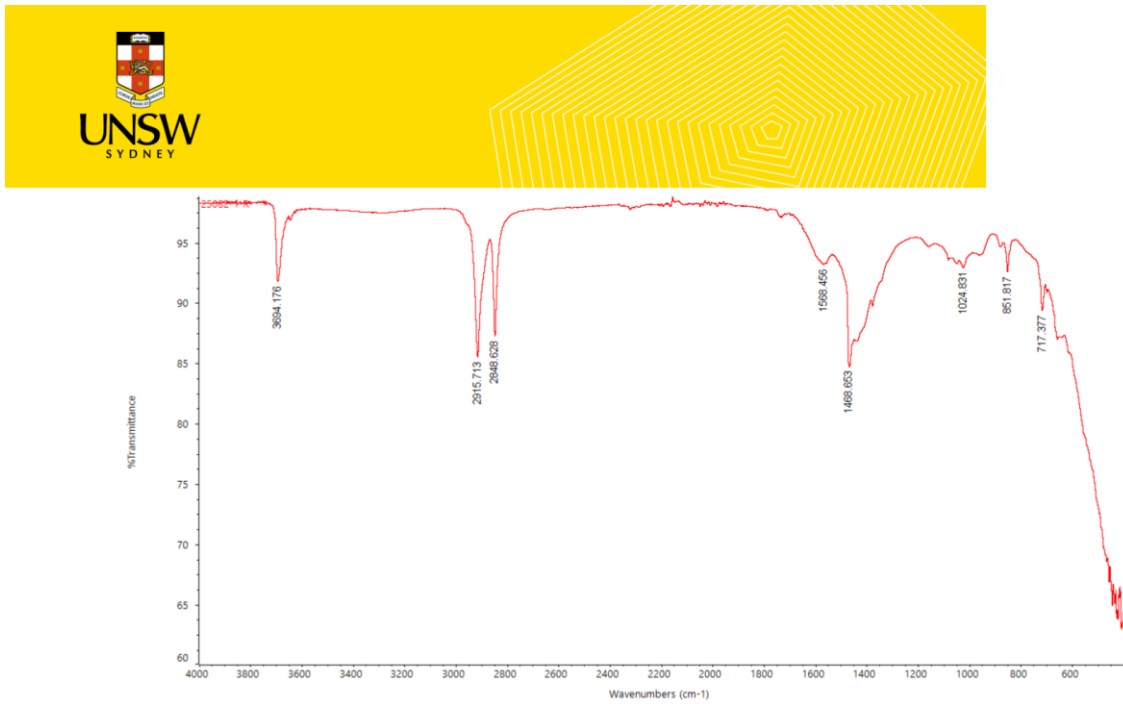

Figure 1. FT-IR spectrum of sample 1



UNSW RESEARCH INFRASTRUCTURE

Chemical Consulting Laboratory

Mark Wainwright Analytical Centre
UNSW Sydney NSW 2052 Australia

T: +61(2) 9348 1400 | E: ccl@unsw.edu.au
W: www.analytical.unsw.edu.au/contact-us/commercial-consulting
ABN 57 195 873 179 | CRICOS Provider Code 00098G

Test Report

Prepared by:

ANALYSIS OF CLADDING SAMPLES

For

Company: Warrington Fire

Contact: [REDACTED]

Date: 22 February 2024

Project No.: 24021

Prepared by: [REDACTED]

Approved by: [REDACTED]



COMMERCIAL-IN-CONFIDENCE

Any use of the Test Report, use of any part of it, use of the names University of New South Wales or UNSW, use of the name of any Unit of UNSW, or use of the name of the consultant in direct or indirect advertising or publicity is strictly forbidden.



Analysis of Cladding Samples

1. SAMPLES

One envelope containing three ACP cores was received for analysis. The samples were identified as follows:

CCL sample coding	Client sample coding
24021-1	#1 - 100%
24021-2	#2 - 100%

CCL has been asked to identify the polymer and the filler (s) in the samples by FT/IR, quantitate and identify the mineral filler in the samples and classify them in accordance with the ICA cladding scheme.

2. METHODOLOGY AND RESULTS

The aluminium metals were removed from the ACPs cladding polymer, and the flat surface of the polymer sample was abraded to remove any surface adhesive. The surface of the sample was analysed directly by FTIR. The FT-IR spectra are presented in Figures 1-3.

The core of the samples was then ashed to determine their percentage mineral content (Table 1). If sufficient (>0.5 g) ash was found in the sample, it was analysed for elemental composition by X ray fluorescence spectroscopy. Results are presented in Table 2.

Table 1 Ash content of 24021-1-3

Sample coding	Ash content (w/w%)
24021-1	3.3
24021-2	3.0

3. CONCLUSIONS

The cladding sample #1 consisted of 3.3% inert material and approximately 96% polyethylene polymer.
The cladding sample #1 is classified as ICA category A.

The cladding sample #2 consisted of 3.0% inert material and approximately 97% polyethylene polymer.
The cladding sample #2 is classified as ICA category A.

The ICA Classification assigned is correct as per the September 2020 revision of the ICA Guidelines.

The reader is reminded that we can only analyse and classify the content of samples actually presented to us. We can offer no guarantee that this composition or classification is valid for cladding as a whole, because some types of cladding can be inhomogeneous, and a sample may not be representative of the cladding as a whole. Anyone using our results should consider these sampling issues and uncertainties before they generalise the results we present to anybody of cladding as a whole.

Senior Technical Officer
Chemical Consulting Laboratory
Mark Wainwright Analytical Centre, UNSW
22 February 2024



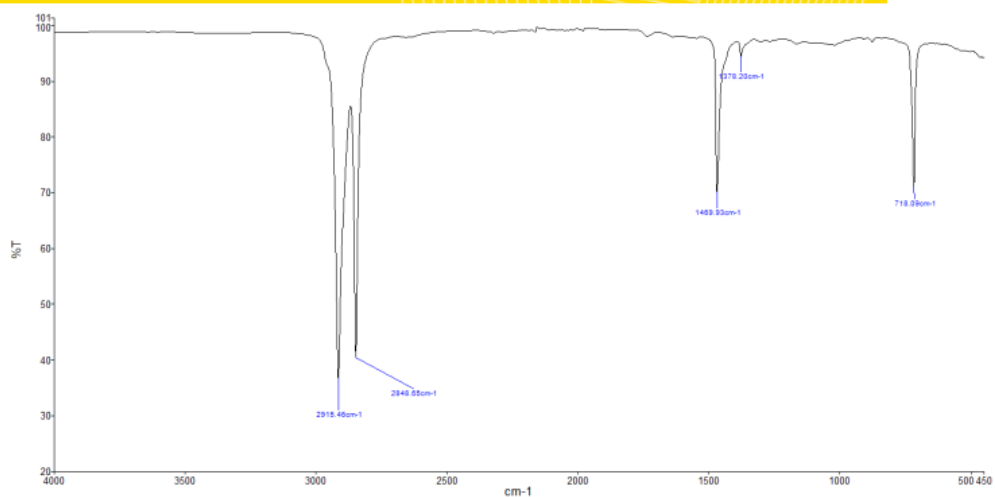

Figure 1. FT-IR spectrum of sample #1

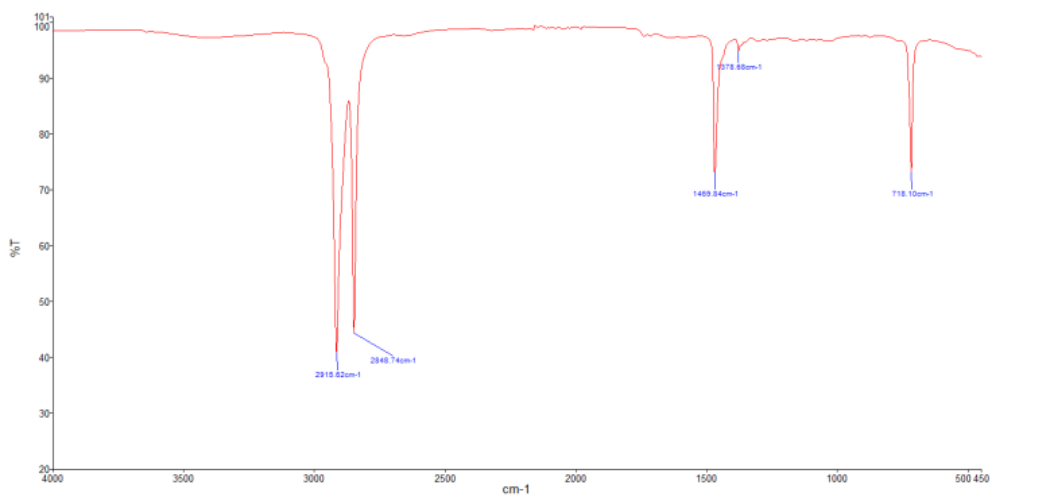

Figure 2. FT-IR spectrum of sample #2





JENSEN HUGHES

Jensen Hughes Fire Testing Pty Ltd
ABN 81 050 241 524

Melbourne – NATA accredited laboratory

409-411 Hammond Road
Dandenong South Vic 3175
Australia
T: +61 3 9767 1000

General conditions of use

The data, methodologies, calculations and results documented in this report specifically relate to the tested specimen/s and must not be used for any other purpose. This report may only be reproduced in full. Extracts or abridgements must not be published without permission from Jensen Hughes Fire Testing.

All work and services carried out by Jensen Hughes Fire Testing Pty Ltd are subject to, and conducted in accordance with our standard terms and conditions.